

**BERNINA**

**MODEL 700**

**FR. GEGAUF LTD.  
BERNINA SEWING MACHINE FACTORY  
STECKBORN/Switzerland**

## 2. Thread tension

(Fig. 4)

BERNINA offers the unique advantage that the thread tension must never be changed. Only two marked lines are provided for control. When the fixed marked line on top arm and the line on mobile part of thread tension device are set one above the other, the perfect thread tension is attained. — With BERNINA sewing machines a numbered scale is not necessary.

By means of the adjusting disc 4 the thread tension can be changed for special purposes wished for. If the marked line 35 is moving behind sight hole 34 to the right, the thread tension will be reinforced; if said marked line is moving to the left, the tension will be weaker. Correct normal tension is set when the mobile marked line 35 is right above fixed marked groove at sight hole.

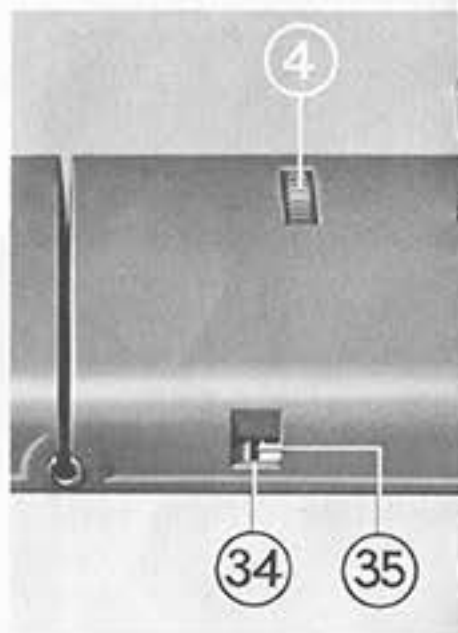

Fig. 4

## 3. Spooling the Under Thread

Pass the thread from the spool-pins 22 through pretension 32 (Fig. 3) into slot 8, then diagonally down to pretension 15 and up to bobbin 26.

(Release handwheel and set presser foot in high position).



Fig. 5

## 1. Threading the Upper Thread (Fig. 2 and 3)

- 4 Thread tension adjusting disc
- 7 Take-up lever
- 8 Thread tension slot
- 22 Spool-pins
- 33 Holder eyelet

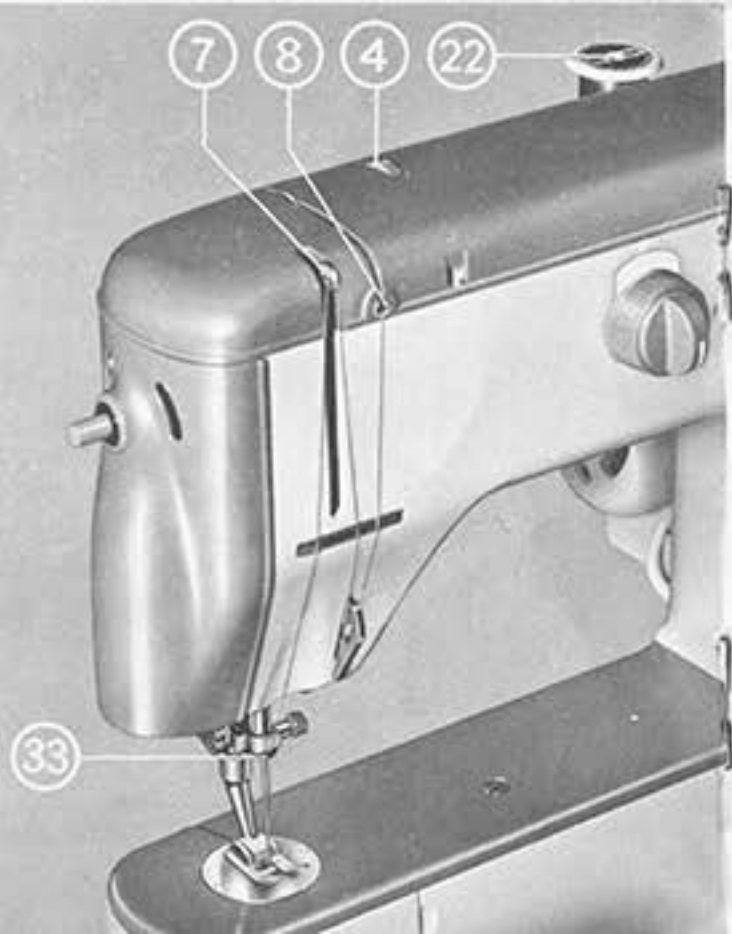
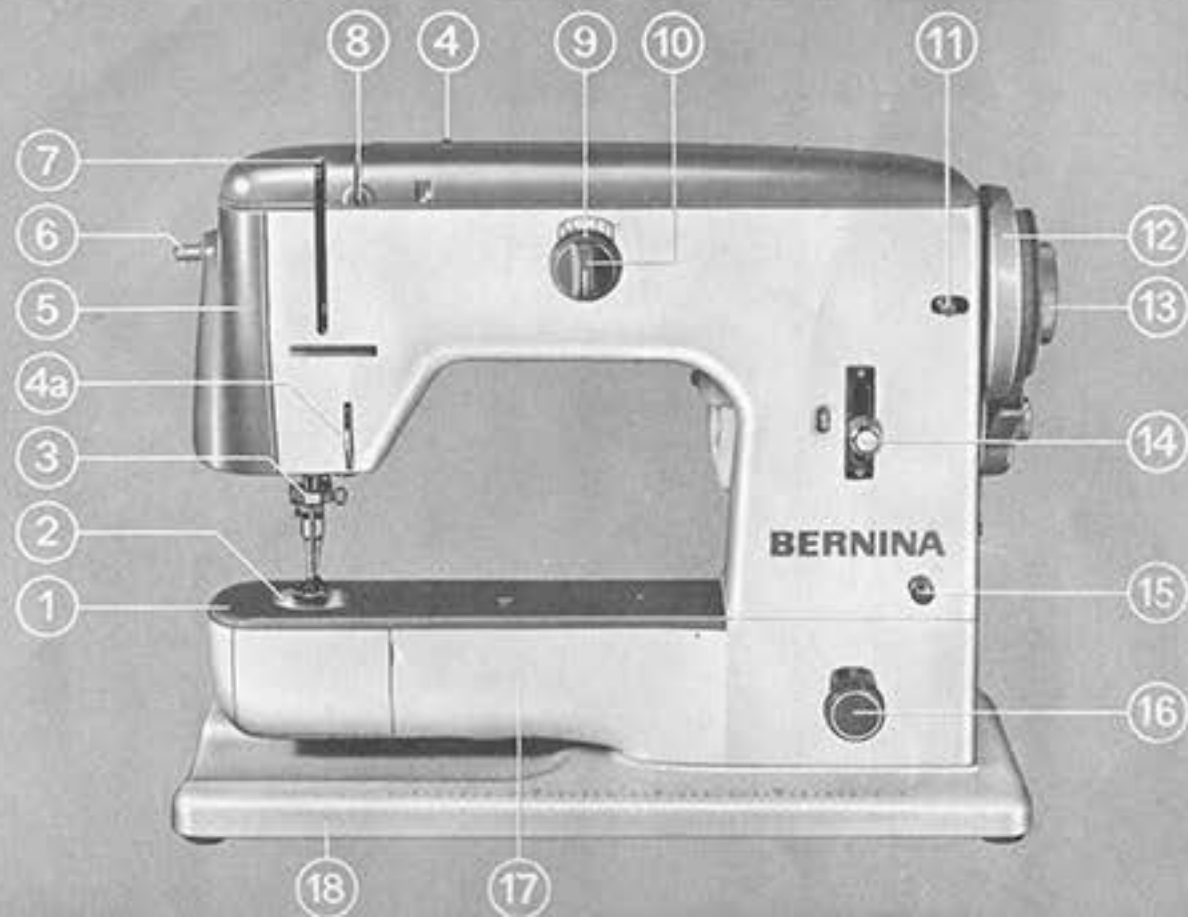

Fig. 2

Place a reel of thread on one of the two spool-pins situated at the back of the top arm (22). From there lead thread through the pre-tension 32, also placed at the back of arm, then into slot running across top arm. In its centre the double thread tension is arranged. The central tension disc is protruding somewhat from slot 8. When sewing with one thread only, it does not matter whether the thread is drawn at the left or at the right of the central tension disc into the tension properly speaking. At the front pass the thread down to thread regulator 4a (Fig. 1), then up again through take-up lever 7, and down once more through needle holder eyelet 33, and finally through needle eye itself from front to rear. When threading make sure that take-up lever 7 and needle are in their highest position.

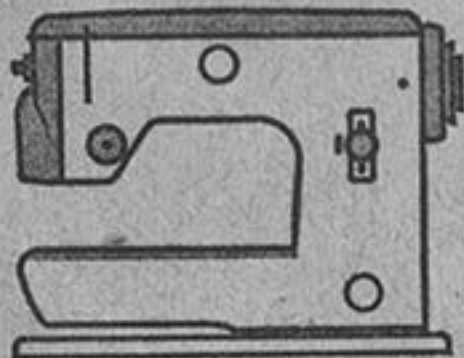

Fig. 3



For the threading, thread tensioning and bobbin winding the BERNINA cl. 700 differs as follows from the former cl. 600:

- |           |   |           |                            |
|-----------|---|-----------|----------------------------|
| <b>1</b>  | Cover plate                               | <b>10</b> | Needle displacement lever  |
| <b>2</b>  | Needle plate                              | <b>11</b> | Bobbin winder shaft        |
| <b>3</b>  | Needle holder                             | <b>12</b> | Handwheel                  |
| <b>4</b>  | Thread tension adjusting disc             | <b>13</b> | Handwheel release          |
| <b>4a</b> | Thread tension regulator                  | <b>14</b> | Stitch length regulation   |
| <b>5</b>  | Face plate                                | <b>15</b> | Winder preliminary tension |
| <b>6</b>  | Lighting switch                           | <b>16</b> | Drop feed knob             |
| <b>7</b>  | Take-up lever                             | <b>17</b> | Free arm                   |
| <b>8</b>  | Thread tension slot                       | <b>18</b> | Base plate                 |
| <b>9</b>  | Shift knob for straight stitch and zigzag |           |                            |



# BERNINA

**Model 600**

Free arm, zigzag sewing machine

**Model 610**

Flat base, zigzag sewing machine



— INSTRUCTION-BOOK —

## Table of contents

Guarantee . . . . .	1	Darning and mending . . . . .	31
Removing and replacing the machine	5	Cross-wise darning of linen, etc.	35
Electrical part . . . . .	10	Darning stockings . . . . .	34
Bobbin case and bobbin		Lap hemmer . . . . .	37
Removing the bobbin case . . . . .	12	Hemmer . . . . .	30
Winding the bottom thread . . . . .	13	Gathering foot . . . . .	40
Inserting the bobbin into the case		Edger . . . . .	41
and threading the bobbin thread;		Zigzag stitch . . . . .	42
Replacing bobbin case into the		Elastic sewing of knitted goods . . . . .	45
shuttle . . . . .	15	Roll hemmer . . . . .	47
Needle and thread . . . . .	16	Braiding . . . . .	48
Threading the top thread; Bring-		Buttonhole sewing . . . . .	49
ing up the bottom thread . . . . .	19	Sewing on buttons . . . . .	54
The thread tension; Fixing the		Darning with wool . . . . .	56
slide-on table . . . . .	20	Appliqué work . . . . .	59
Cleaning and oiling . . . . .	21	Ornamental stitches . . . . .	60
Plain stitch		Feather stitch . . . . .	68
Exchanging the presser foot . . . . .	25	Pin-tucking . . . . .	69
Lowering the feed dog . . . . .	27	Embroidering around holes . . . . .	73
Forward and backward sewing . . . . .	29	Useful hints . . . . .	77
		Normal accessories . . . . .	Inside back cover



## CERTIFICATE OF GUARANTEE

for the Sewing Machine

Model 600/610      No. *61106285*

(Please quote in your correspondence)

(Terms of guarantee  
overleaf)

### Validity of Guarantee

Machine: 5 years, until *11/1/69*

Motor: 2 years, until *11/1/66*

This certificate should  
be signed on the basis  
of the terms listed over-  
leaf after instructions  
have been given.

City and date: *Staines*

Signature of Dealer: *[Signature]*

1 CHURCH STREET

Tel: STAINES 2285

### Terms of Guarantee

We engage to repair, free of charge, any defects due to faulty material or workmanship arising during five years in the machine, and during two years in the motor of the Bernina Model 600 or Model 610 Sewing Machine supplied by us. All other claims are excluded from this Guarantee, which is valid only towards the first buyer of the machine.

This Guarantee becomes valid on the day of delivery of the machine. A buyer wishing to claim under the Guarantee should return the machine to the Bernina Dealer who sold the machine or if this is impossible to the General Agency of the country where the buyer is living or directly to the Manufacturers. Transport charges as well as any damage caused by faulty packing are at the buyer's expense.

This Guarantee does not cover normal wear and any damage ensuing therefrom, such as cable breakage, burning out of electric bulb, wear of motor carbon brushes and the like.

This Guarantee does not apply if the Instructions for use are disregarded, if the machine is not properly cleaned and lubricated, if third persons not appointed by us are allowed to effect alterations or repairs. Damage due to faulty manipulation is not covered by this Guarantee.

This Guarantee is valid only if high-grade sewing machine oil and needles System 705 are used.

Fritz Gegauf Ltd.      BERNINA Sewing Machine Factory      Steckborn - Switzerland

Buyer  
of  
Machine

Name and Surname: MR. J. Carter  
Street: 7 Portland Road  
Town: Asford, Middx.  
Date of delivery: 14/1/64

(Signature of Buyer)

Supplier  
of  
Machine

SEWMASTER  
SEWING MACHINES  
1 CHURCH ST  
STAINES  
Tel: STAINES 2255  
(Signature of Supplier)

Remarks of the BERNINA Agent concerning instructions, home visits and eventual guarantee work

Date	Remarks

## Removing and replacing

Fig. 1

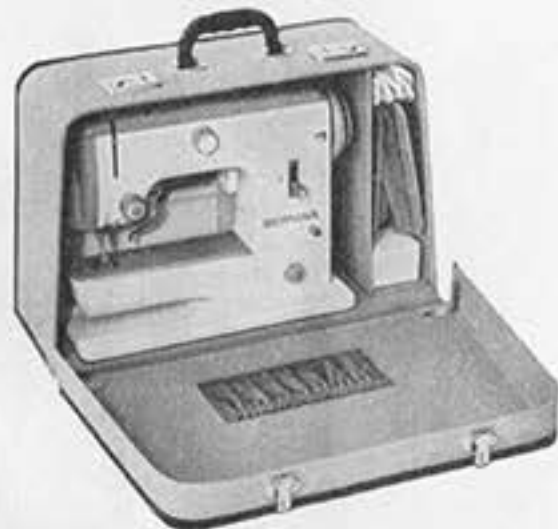

In order to be able to take the machine out of the carrying case, set the case upright on a table and open it, as shown in Fig. 1. Take hold of the machine under the upper arm and lift it out.

When replacing the machine into the case, be sure that the handwheel is at the correct side, as otherwise the case cannot close. On the inside bottom of the case there is a drawing which shows how to place the machine.



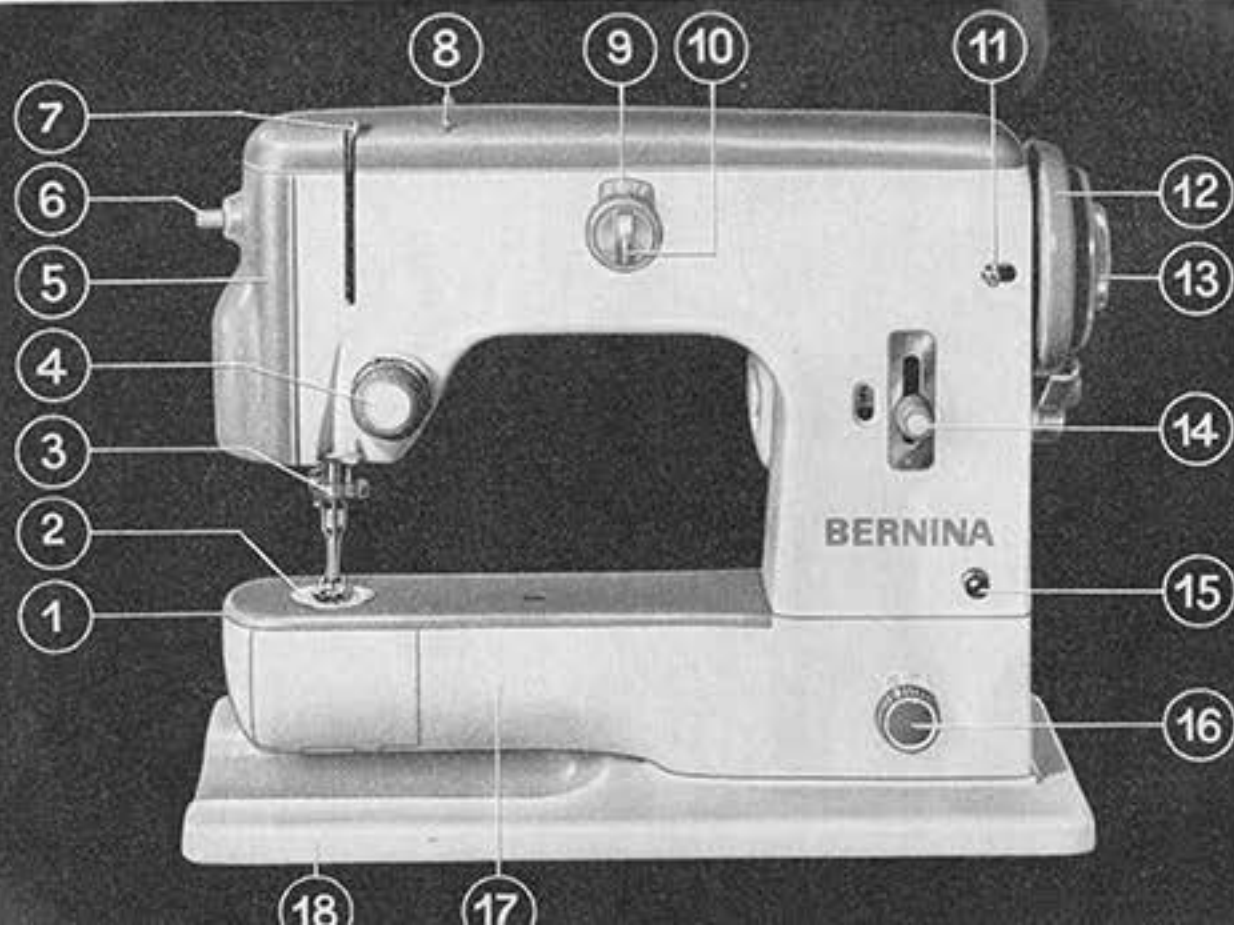

Fig. 2 on the preceding page shows a BERNINA Model 600, the controls, etc. mentioned in the Instruction Book being numbered and named in the list below.

- |   |  |    |                            |
|---|--|----|----------------------------|
| 1 | Cover plate                                  | 10 | Needle displacement lever  |
| 2 | Needle plate                                 | 11 | Bobbin winder shaft        |
| 3 | Needle holder                                | 12 | Handwheel                  |
| 4 | Thread tension                               | 13 | Handwheel release          |
| 5 | Face plate                                   | 14 | Stitch length regulation   |
| 6 | Lighting switch                              | 15 | Winder preliminary tension |
| 7 | Take-up lever                                | 16 | Drop feed knob             |
| 8 | Thread guide                                 | 17 | Free arm                   |
| 9 | Shift knob for straight<br>stitch and zigzag | 18 | Base plate                 |

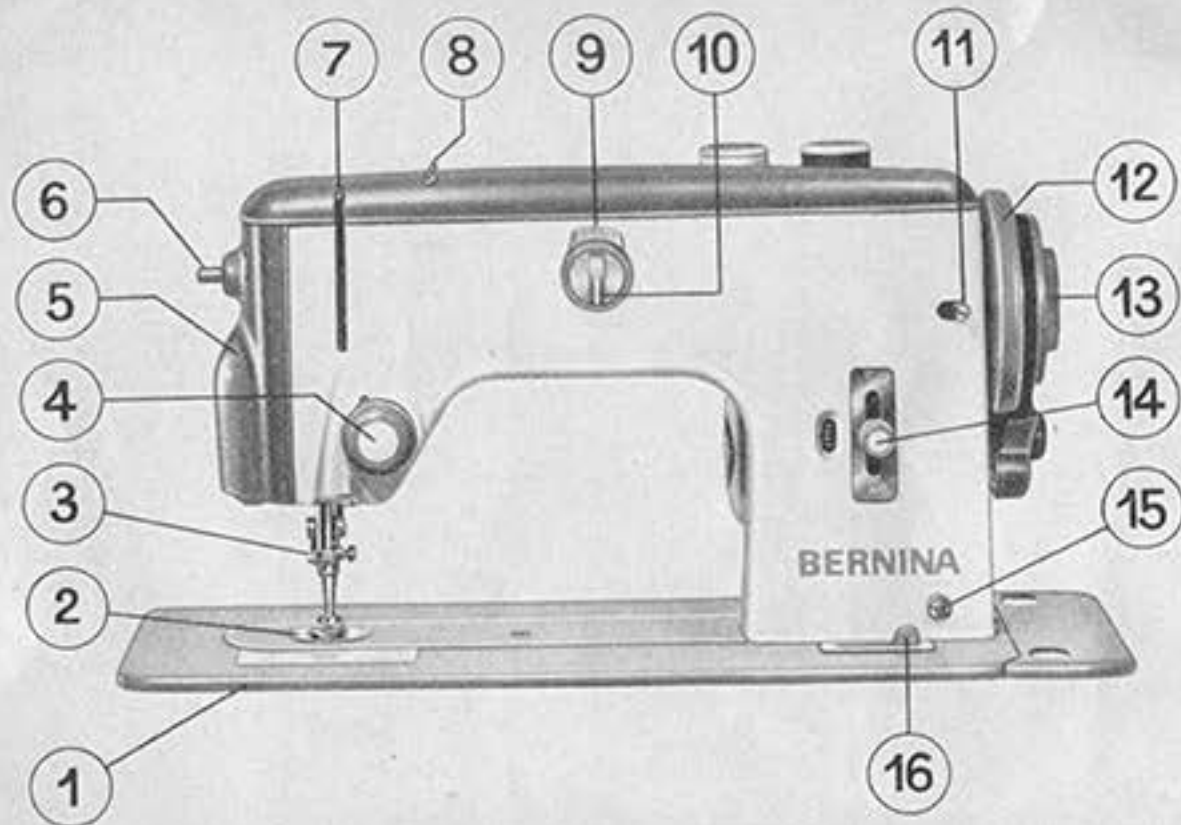

Fig. 3 on the preceding page shows a BERNINA Model 610, the controls, etc. mentioned in the Instruction Book being numbered and named in the list below.

- |   |                 |    |  |
|---|-----------------|----|--|
| 1 | Base plate      | 9  | Shift knob for straight<br>stitch and zigzag |
| 2 | Needle plate    | 10 | Needle displacement lever                    |
| 3 | Needle holder   | 11 | Bobbin winder shaft                          |
| 4 | Thread tension  | 12 | Handwheel                                    |
| 5 | Face plate      | 13 | Handwheel release                            |
| 6 | Lighting switch | 14 | Stitch length regulation                     |
| 7 | Take-up lever   | 15 | Winder preliminary tension                   |
| 8 | Thread guide    | 16 | Drop feed knob                               |

Fig. 3 Model 610

## Electrical part

Fig. 4

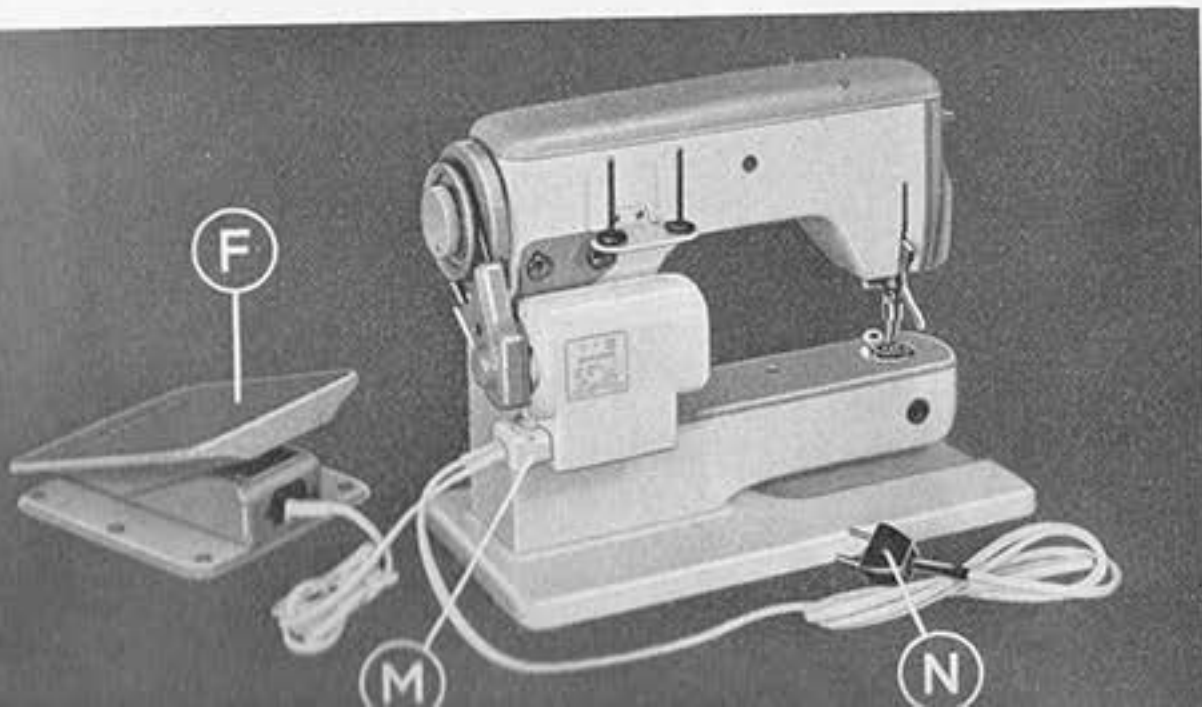

The drive of the BERNINA Model 600 and Model 610 is by a universal motor placed at the rear. A so-called data plate, with particulars of the voltage and power of the motor, is fitted on the motor housing (Fig. 4). Before connecting the flex to the mains, make perfectly sure that the voltage on the data plate corresponds to the voltage of the mains. The latter is given on the electric meter in your house. This checking must always be made, particularly if the machine is to be used away from home. Do not rely on the voltage marked on plugs and sockets.

Underneath the motor a switchbox for a plug-in device with 3 flat pins is arranged. The plug (M) fitting into this device is provided with a cable for connecting to the lighting mains and also with a cable leading to the foot starter.

After the 3-pin plug (M) has been inserted into the plug-in device of the motor, plug the main cable (N) into the socket of the lighting mains. The machine is now ready for use.

By gently pressing on the footplate (F) of the starter, the machine is put into motion. The more the footplate is pushed down, the quicker will the machine run. Exercise regulating the speed a few times, without any thread in the machine.

The sewing lamp is fitted in the swivelling head-cover free from dazzle. By pressing the button of the lighting switch, the lamp can be switched on and off. The bulb can be changed as usual in ordinary lamps. For taking the bulb out, turn it counterclockwise; for inserting it, turn it clockwise.

## Bobbin Case and Bobbin

Fig. 5

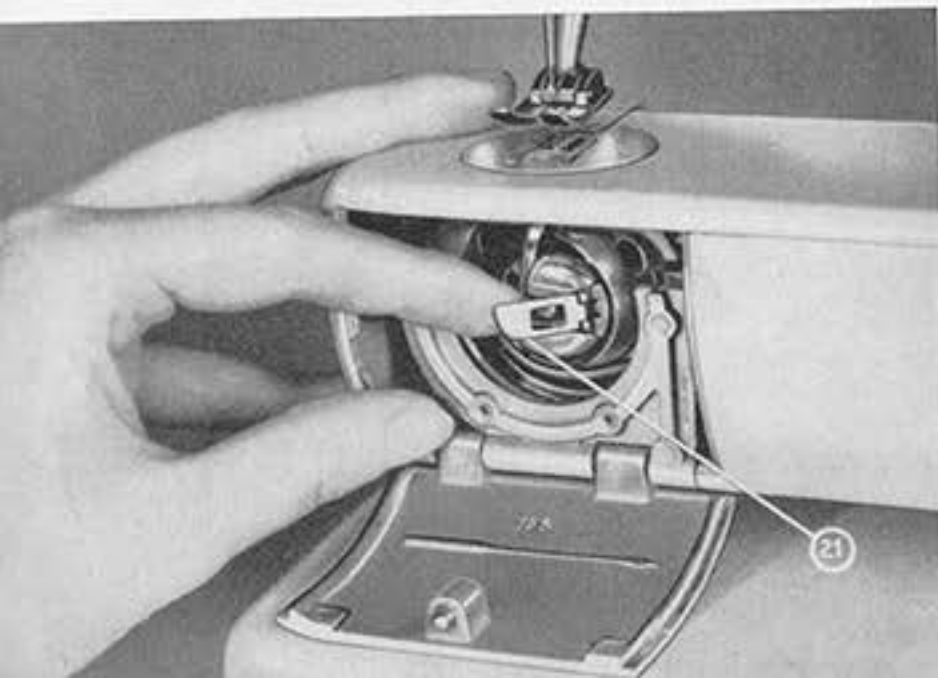

### Removing the bobbin case

Set the take-up lever 7 (Fig. 2) approximately in its highest position. With the index finger of the right hand, open the hinged shuttle cover. Then, with the index finger of the left hand, open the hinged latch 21 (Fig. 5) and withdraw the bobbin case together with the bobbin. When the latch is released, the bobbin is freed and then drops out of the case.

### Winding the bottom thread

A neater stitch is obtained if the bottom thread is chosen somewhat finer than the upper thread.

The reel from which the winding has to be done is placed onto one of the two reel pins 22 (Fig. 6). In order that the whole machine may not run needlessly when winding, turn with your right hand the handwheel release screw 13 as far as possible towards you, at the same time holding the handwheel 12 firmly with your left hand.

Fig. 6

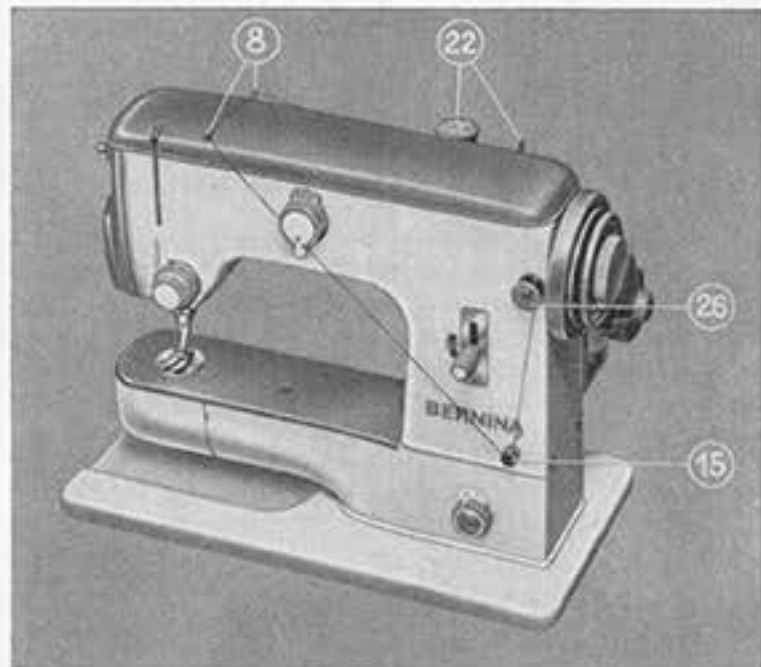

Slip bobbin 26 onto the bobbin winder shaft projecting out of the vertical arm, and turn the bobbin slowly until the spring in the winder shaft engages in the slot of the metal bobbin. This spring ensures that the bobbin turns with the shaft.

Bringing the thread to the bobbin is a very simple matter. From the thread reel placed on the pin 22, pass the thread first through the two thread guides 8, and from there downwards between the tension discs of the winder preliminary tension 15 onto the bobbin 26.

Then press the bobbin to the right until a resistance is felt. The winder now comes into engagement.

Then start the motor by pressing gently on the footplate of the starter. Take care never to fill the bobbin quite to the edge. After finishing the winding operation, press the bobbin to the left so that it comes out of engagement; remove the bobbin from the winder shaft. Finally tighten the handwheel release screw 13 again.

#### Inserting the bobbin into the case and threading the bobbin thread Replacing bobbin case into the shuttle

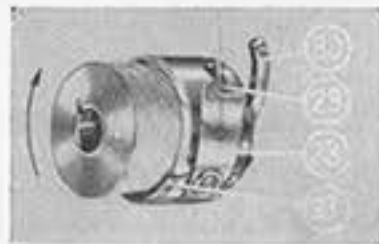

Fig. 7

When placing the bobbin into the case, make sure that the bobbin turns in the direction of the arrow when the thread is pulled.

After inserting the bobbin, pass the thread into slot 27, pull it through below the tension spring 28 and allow it to come out at the end of tension spring 29.

Insertion of the bobbin case is only possible when the needle is in its raised position. Hold the case by the opened latch as when removing it (Fig. 5). Index finger and thumb of the left hand hold the hinged latch so that the horn 30 (Fig. 7) points upwards and engages the recess in the shuttle race cover. Then place the bobbin case on the shuttle pin as far as it will go. Now release the latch and make sure whether it is properly closed. If the hinged latch does not close easily, thread ends or fluff have collected at the base of the shuttle pin and must be removed.

## Needle and Thread

### Setting the needle

Use only System 705 needles. Needles with blunted points or bent needles may not be used. Turn the handwheel towards you until the needle bar is at its highest point. Hold the needle between thumb and index finger of the left hand so that the long *groove faces you*. The *flat side* of the needle shank must therefore be at the rear. Now loosen the needle holder screw by turning it counterclockwise and insert the needle, pushing it up as far as it will go. Then tighten the needle holder screw by turning it clockwise. It is important that the needle should be pushed right up to the needle stop and firmly clamped by the needle holder screw.

### Proper choice of needle and thread

For the Bernina Models 600 and 610 use exclusively System 705 needles. In order to obtain satisfactory sewing results, use only needles of the best quality and first-class thread.

First select the thread suitable for the work; then the needle suitable for the thread, making use of the table on the next page.

The relation between needle and thread is correct if the thread, when placed in the long groove of the needle, fills the latter well and can be freely pulled up and down in it.

For sewing, use generally the needle Nos. 80, 90 and 100, and for darning the needle Nos. 70 and 80.

### Needle and thread table

Needle System 705 No.	Sewing thread		Darning thread
	6-ply (unglazed)	3-ply (unglazed)	2-ply
60	-	170-200	80-100
70	70-100	70-140	50-80
80	50-60	50-70	30-40
90	40-50	30-40	-
100	20-30	-	-

### Suitable thread for sewing and darning

For plain sewing: Nos. 60-90, 3 and 6-ply, unglazed

For darning: Nos. 50-80, 2-ply

For zigzag sewing: Nos. 60-90, only 3-ply

For ornamental sewing: Nos. 30 and 40, 2-ply

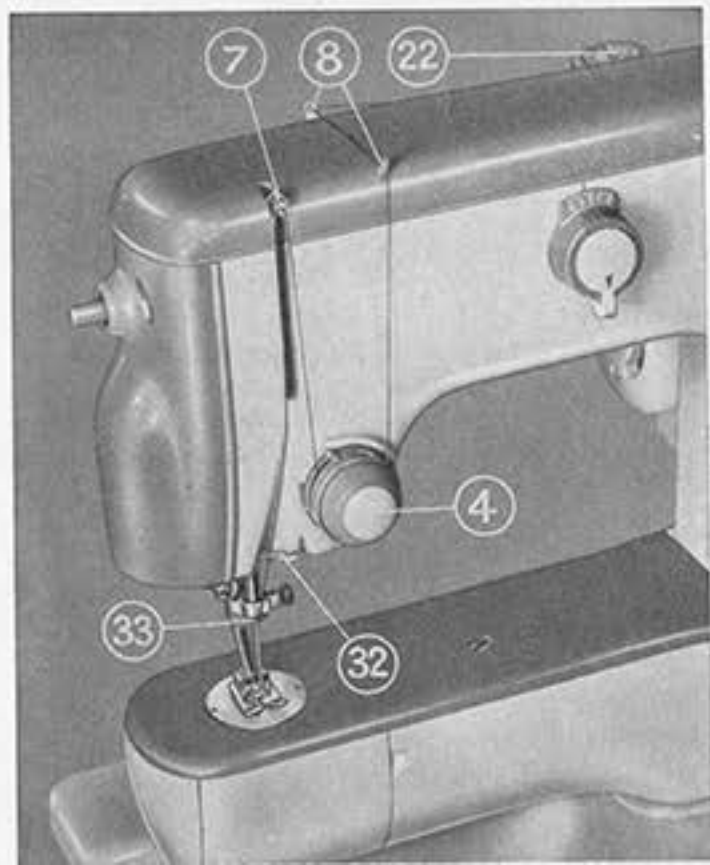

- 4 Thread tension
- 7 Take-up lever
- 8 Thread eyelets
- 22 Spool pin
- 32 Thread guide pin
- 33 Needle clamp thread guide

Fig. 8

**Threading the top thread Fig. 8**

Place the thread spool on one of the two spool pins 22, fitted behind the arm. From there pass the thread through the rear eyelet 8, then through the front eyelet 8 down to the thread tension between the tension discs, up to the hole in the take-up lever 7, then again down behind the thread guide pin 32, into the needle clamp thread guide 33, and finally from front to back through the eye of the needle. Make sure that take-up lever 7 and needle are in their highest positions when threading the machine. Thread tension 4 is formed as a double tension. When only one thread is inserted, it is immaterial whether the thread is between the front or the rear tension disc.

**Bringing up the bottom thread**

Hold the end of the top thread projecting from the needle eye loosely between thumb and index finger of the left hand, while turning the flywheel towards you by one revolution with the right hand, until the take-up lever is approximately in its highest position. Now pull the upper thread end slightly, thus causing the bottom thread to come up. Tighten top and bottom threads slightly and lay them to the rear under the presser foot.

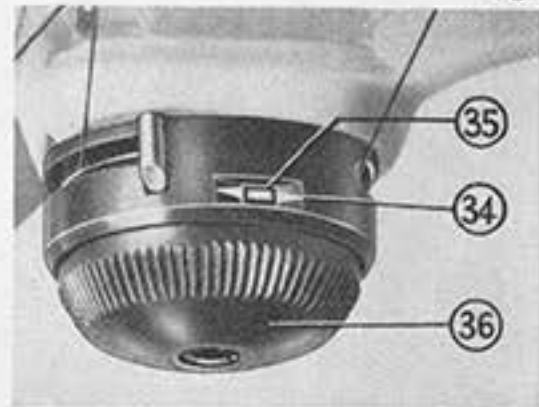
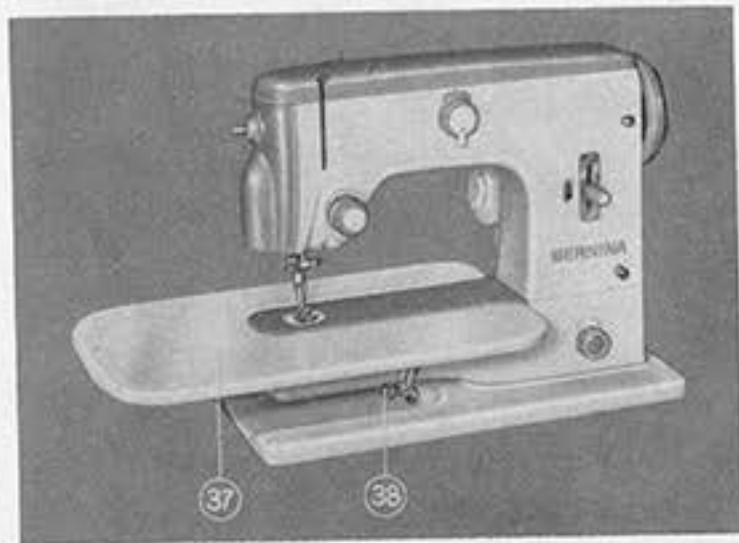

Fig. 9

## The thread tension Fig. 9 (Page 19)

Set the thread tension in such a way that it can be used for all normal sewing and darning work without any special adjustment. On the upper portion of the thread tension box there is a sight hole, which has a reference line 34 at both sides. Below this reference line is situated the white ring 35 on the adjusting nut 36, marking the normal adjustment of the thread tension.

Fig. 10



## Fixing the slide-on table

Fig. 10

The slide-on table 37 is accommodated in the rear wall of the carrying case, and held there by a catch. After turning the catch clockwise, the table can be taken out.

When sliding the table onto the free arm, make sure that the locking lever 38 is pointing to the right. In order to clamp the sewing table rigidly to the free arm, set the lever vertical.

## Cleaning and Oiling

### Cleaning the machine Fig. 11 and 12

During the sewing particles of thread are produced, and collect particularly round the shuttle in the form of fluff. Such fluff may detrimentally affect the proper functioning

of the machine, and it is therefore absolutely necessary to remove it frequently. From time to time, remove cover plate 1 so that the fluff collected under the needle plate can be cleared away.

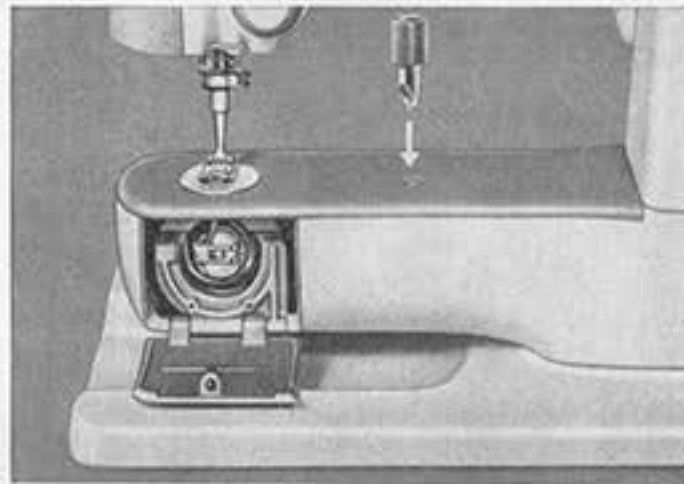

Fig. 11

For this reason, the cover plate is designed so that it can easily be removed, i. e. it is fixed with only one screw, in order that cleaning and oiling can be conveniently effected.



To remove the cover plate, open the hinged plate to the shuttle and loosen the fixing screw with the special screwdriver, as shown in Fig. 11. The presser foot need not be removed, but the needle should be placed in its highest position.

To insert the cover plate, lay it on the free arm of the machine in such a way that the two pins on the arm fit into the holes in the cover plate. Then fix the cover plate again with the fixing screw.

#### Oiling the machine

The sewing machine should be oiled frequently, but not too liberally. A few drops of oil suffice to keep the machine running freely. Excess oil will drain off unused and may soil the sewing work. Always oil the machine *before beginning to sew*, and not afterwards. Use clear oil free from resin and acid, such as is supplied by all Bernina dealers.

If an inferior oil is used, there is a risk of the machine jamming when the oil dries and becomes tacky. In Fig. 13 the oiling points are indicated by reference lines. Opening the hinged cover at the front of the free arm gives access to the shuttle, whose race should be oiled frequently, but only slightly at the points indicated by an arrow (Fig. 14).

*Adequate oiling ensures quiet operation of the machine and lengthens its life. The oiling points not visible in Fig. 13 are marked red on the machine.*

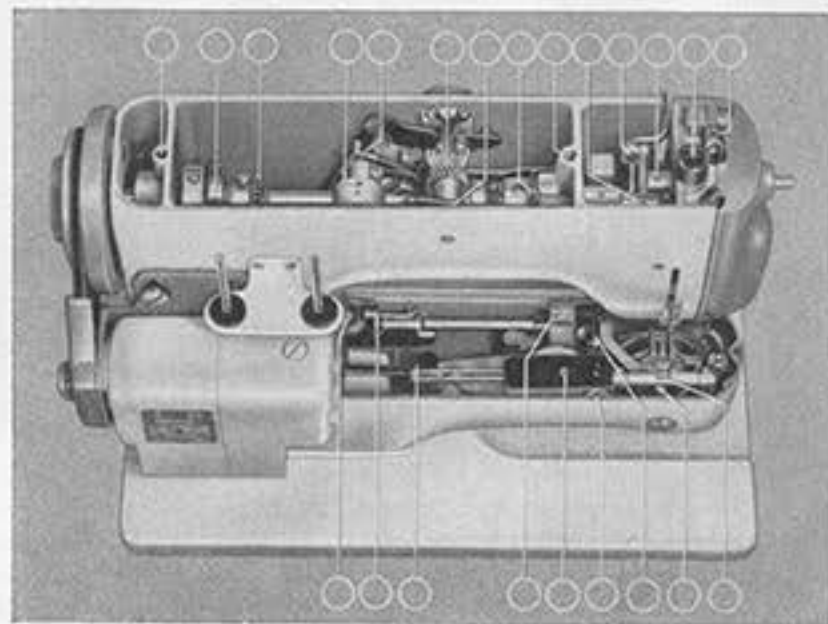

Fig. 13

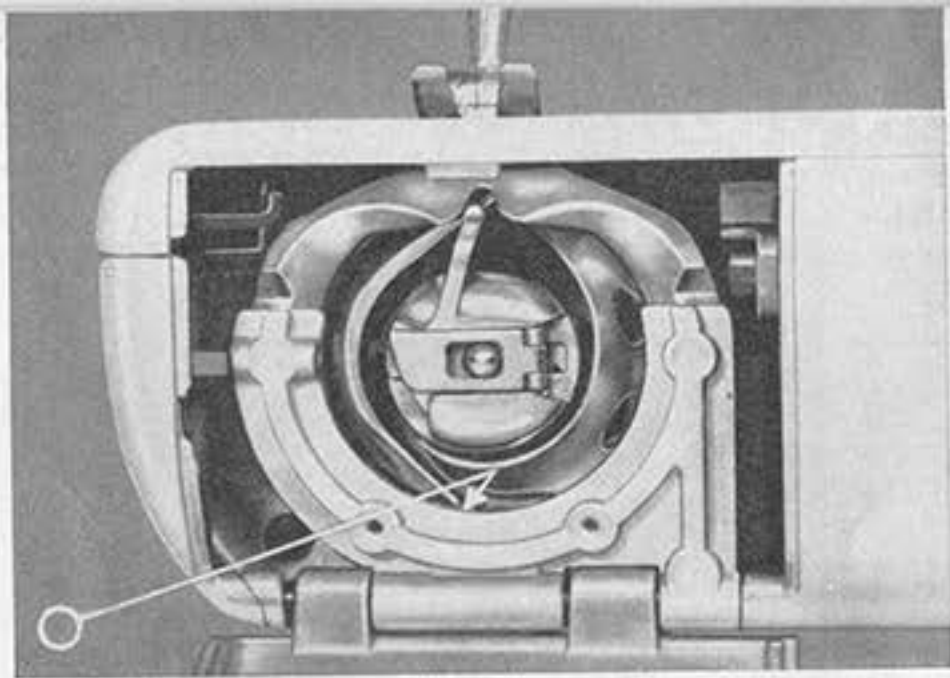

Fig. 14

If the machine has been standing in a cold room, it should be brought into a warm room and opened about an hour before being used, in order that the machine may acquire the temperature of the room, and the oil in the bearings thus becomes liquid again.

## Plain Stitch

### Plain stitching with normal and special presser feet

#### Exchanging the presser foot

The different kinds of sewing require more or less frequent changing of the presser feet. This is why the BERNINA Models 600 and 610 have been equipped with a presser foot holding device which does not need the aid of a screwdriver, but nevertheless ensures reliable seating of the presser foot.

#### a) *Removing the presser foot* Fig. 15

With the lifting lever situated on the rear of the head, lift the cloth presser bar along the presser foot. Now raise clamping lever 41, which engages below the clamping boss 42 of the presser foot 43, far enough for the hook 44 of the clamping lever to release the clamping boss 42 completely. The presser foot will drop from the cloth presser bar automatically or with a little help, and can easily be removed.

b) When replacing the presser foot proceed in the opposite sequence: After raising the cloth presser bar by means of the lifting lever, hold the shank of the presser foot between thumb and index finger of your left hand, and place the presser foot below the cone of the cloth presser bar. Now lift the clamping lever 41 with your left hand and slide the presser foot onto the cloth presser bar cone, making sure that the screw 45

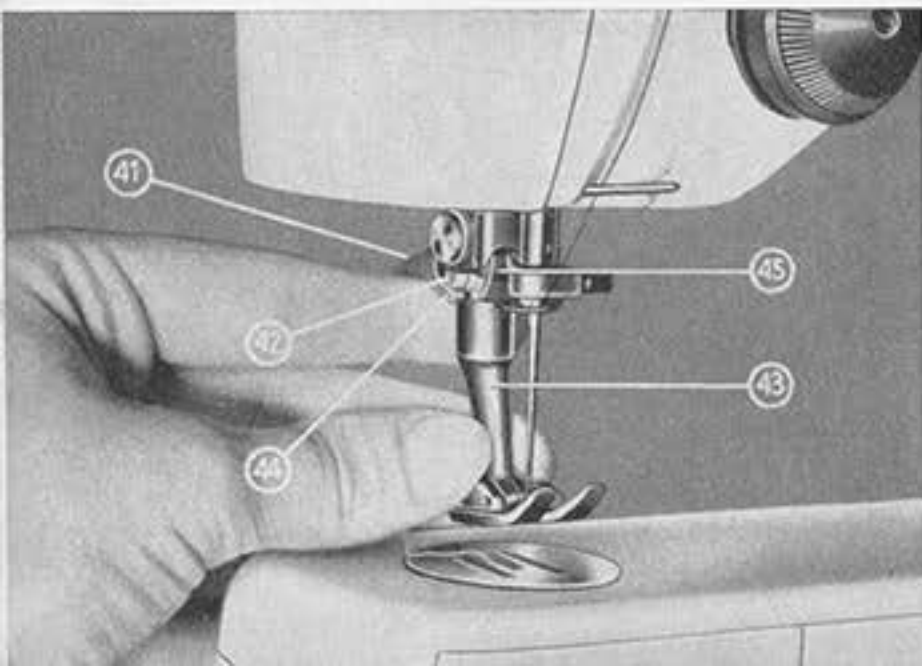

engages in the guide of the presser foot. Then depress the clamping lever so that it can engage below the clamping boss of the presser foot. Quite a slight pressure exerted on the lever will suffice to secure the presser foot firmly on the cloth presser bar cone.

Fig. 15

#### Lowering the feed dog Fig. 16

(Holds good for Model 600)



On the front of the machine, below at the right, there is a control knob 16 with which the feed dog can be lowered or raised, i. e. put out of action or brought back into the sewing position. According to whether the knob is turned counterclockwise or clockwise, the mark on the knob shows on the symbol of the scale 46 that the feed dog is in action, and the machine can therefore be used for sewing, or on the symbol that the feed dog is lowered, as is necessary for darning.



Fig. 16

### Lowering the feed dog (Holds good for Model 610)

Below at the right on the machine there is a control lever 16, with which the feed dog can be lowered, i. e. put out of action, or can be brought into the sewing position (Fig. 17).

If the lever is at the right, the feed dog is in action (symbol  on the scale plate). The machine can now be used for sewing. If the control lever is at the left (symbol ) the feed dog is lowered, as is necessary for darning.

### Plain stitching

(Plain stitch presser foot can be supplied as an extra)

For plain stitching adjust the machine as follows:

1. Raise take-up lever approximately to its highest point.
2. Insert plain stitch presser foot. (For ordinary plain stitch work, the zigzag presser foot may be used as well). Thread the needle *from front to back*. Lay top and bottom threads together to the back under the presser foot.
3. Set feed dog control knob to the sewing symbol by turning it counterclockwise.
4. Adjust stitch regulator so that the zero mark of the stitch length scale is slightly below the marking line at its right. This is only possible if screw 14 (Fig. 2) is not quite screwed in.
5. Set zigzag knob to zero. In this position the machine will do plain sewing. Normal stitch length about  $1\frac{1}{2}$ . As soon as the knob is turned clockwise, a zigzag stitch will be made.
6. Slide the sewing table on.

Make sure that the handwheel is always turned to the front, i. e. towards you.

### Forward and backward sewing and adjustment to various stitch lengths

According to the setting of the stitch regulating lever the machine sews forwards or backwards, making long or short stitches. If the lever is depressed so that the zero line on the stitch length scale is below the marking line at the side, the machine sews for-



Fig. 17

wards. If, on the contrary, the lever is raised, so that the zero line is above the marking line, the machine sews backwards. Forward and backward sewing serves to strengthen certain sewing areas and to secure the ends of the threads.

The more the lever is displaced upwards or downwards, the longer the forward or backward stitch becomes. In order to ensure that the forward and backward stitches are of the same length, the lock screw 14 limiting the upward and downward movement of the stitch regulator lever is turned outwards or inwards to a greater or less degree. If the said screw is turned inwards, the displacement of the lever is reduced.

#### Removing work from the machine

Raise the take-up lever into its highest position and then lift the presser foot by means of the lifting lever. This releases the top thread tension, so that the work can easily be removed without any previous pulling of the threads. In particular, take care always to pull the work towards the rear from under the presser foot, since otherwise the needle gets bent, thus causing thread breakage and faulty stitches.

## Darning and Mending

Fig. 18 a b c

When setting the machine for darning and mending, proceed as follows:

1. Raise take-up lever
2. Remove presser foot and insert hopper foot.
3. Lower feed dog by turning knob clockwise to produce the darning symbol. (With Model 610, move lever 16 [Fig. 17] to the left).
4. Set stitch regulator to zero, so that feed dog is not operated unnecessarily.
5. Set zigzag knob to zero.

The BERNINA Model 600 can be used for darning with or without the slide-on table, depending on the type of work.

### Cross-wise darning of linen, etc.

Cross-wise darning is very simple with the Bernina, because of the patented hopper darning foot.

Fig. 18 a

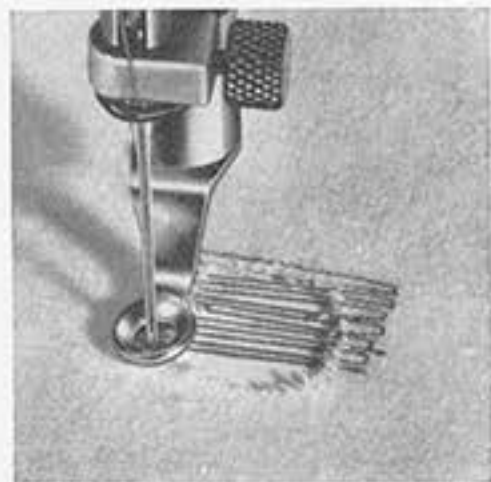

Start by sewing stitch rows from left to right and vice-versa (Fig. 18a). These rows should be parallel and as close to one another as possible. Do not extend the rows beyond the edge of the damaged area farther than is absolutely necessary to secure the stitches. It is advantageous to make rows of different lengths in order to prevent the material from tearing at edge of the darned area when in use later.

Then cover these parallel rows with new parallel rows running at right angles from front to back and vice-versa.

Sew the first covering rows a little beyond the outermost first rows (Fig. 18 b) in order to obtain a uniform and strong darned area. These covering rows should lie as close to each other as possible and run parallel.

Now fill-out the small gaps in the darning area by sewing a number of additional covering rows, but not extended beyond the edge of the original hole (Fig. 18 c).

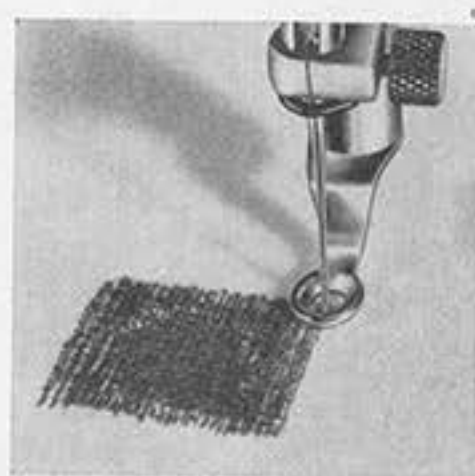
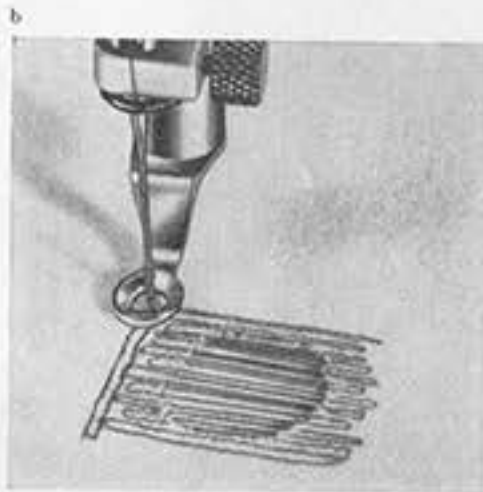

### Darning stockings

Darning stocks is rendered especially easy and convenient by the Bernina Darning Attachment. It is very easy to handle.

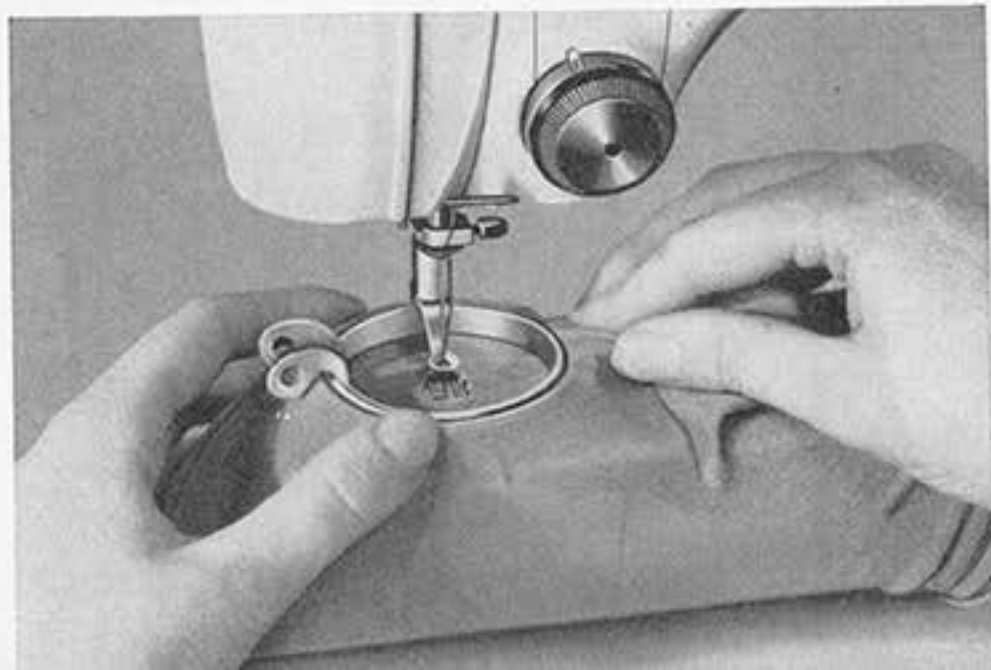

Fig. 19

Place the complete attachment on the free arm and set the small stud at the shank end into the hole in the arm cover 48. Then lift the inner ring 49 of the darning attachment off the outer ring by pressing the two finger tongues 50 together. Now pull the

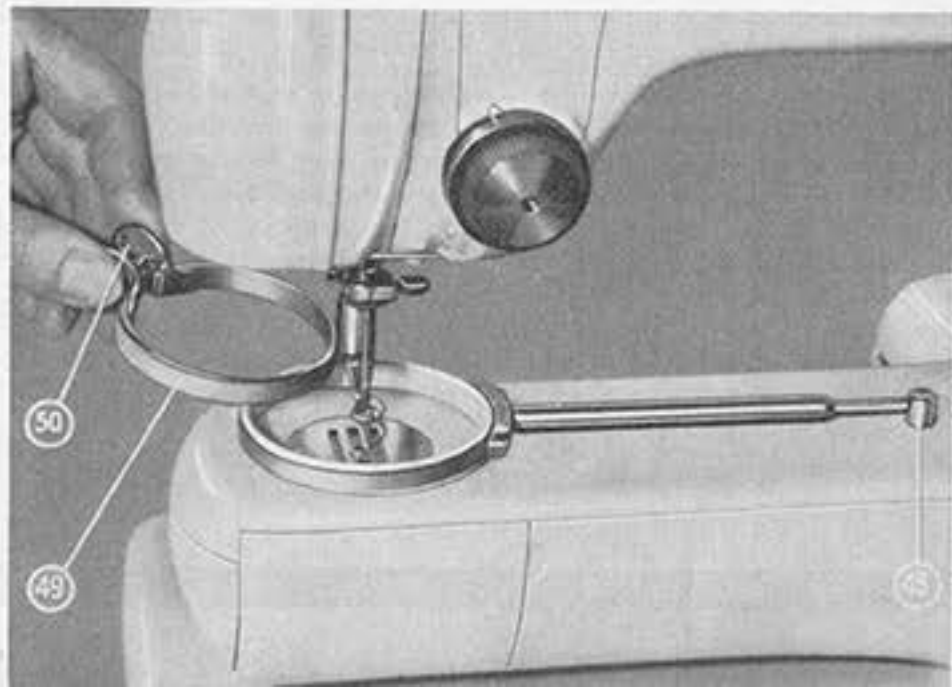

Fig. 20

stocking over the free arm and the darning attachment until the damaged area is centred in the darning ring. It is advantageous to slide the darning ring as far to the left as possible, in particular if the damaged area is at the top or heel. Then clamp the inner ring into the outer ring now covered by the stocking (Fig. 20), and make sure that the stocking area is uniformly tightened. Press inner ring as far as it will go so that the damaged area rests on the throat plate. The damaged area now centered in the ring can easily be moved in any direction.

When beginning, it is usual to sew a full circle around the damaged area to prevent running. Then sew a line of stitches across the direction of the fabric stitches. The lines should be of different lengths and as close to one another as possible. This is done by sliding the darning ring forward and backward. As soon as the hole is completely sewn over, cover these lines in the direction of the knit stitches by moving the darning ring from left to right and vice-versa. The inner ring may also be turned by one-quarter turn and the darning ring then again moved forward and backward. Start these covering lines somewhat beyond the outermost stitch lines (cf. Fig. 18b). The covering lines, which should be of different lengths, should be disposed side by side in line with the fabric stitches. Now fill the small spaces in the mended area until the hole is uniformly covered.

## Lap Hemmer

Tailored effect obtained by having both rows of stitching on the R.S. Can be used to make Run and Fell seam; useful for nightwear, underwear and children's garments.

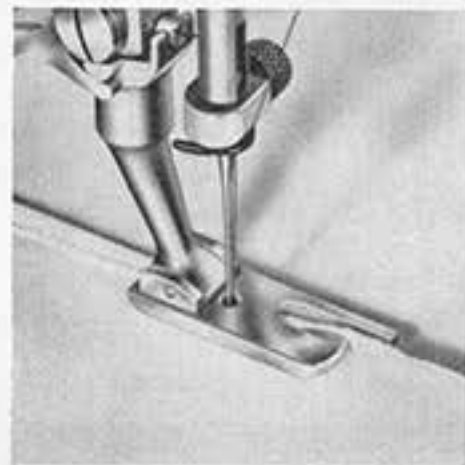

a

Fig. 21

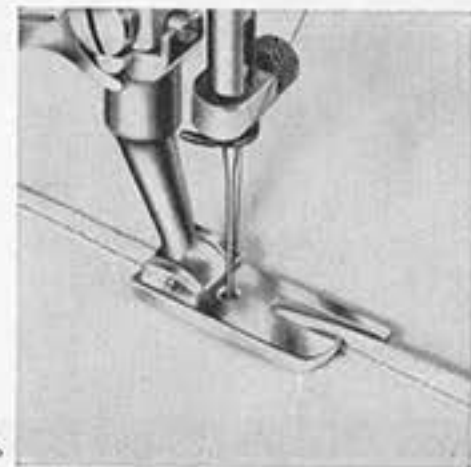

b



Lap hems are used to produce very firm seams. They are obtained in two operations, viz. :

**1st Operation (Fig. 21a):** Arrange the fabric sections to be joined on top of each other in such a manner that the bottom section slightly projects from the top one and pass with sections touching both under the lap hemmer as when hemming so that they are folded over. Make sure that the same width of material always enters the lap hemmer.

**2nd Operation (Fig. 21b):** The two sections are now unfolded and laid flat so that the seam formed stands up like a pleat. This pleat is again passed into the lap hemmer in the same direction so that it is folded over and sewn down.

(Hem width approx.  $\frac{3}{32}$ " )  
(Available as an extra)

## Hemmer

Insert the hemmer in place of the ordinary presser foot, raising the presser foot bar for the purpose.

Fold the edge of the material over to the desired hem width and pass the fabric into the spiral-type guide tongue of the raised hemmer until it is under the needle, then lower the hemmer. When sewing, guide the prefolded edge quite gently (Fig. 22). If too much fabric enters the hemmer, the seam will become bulgy and uneven; if too little enters, the hem will not be folded in sufficiently.

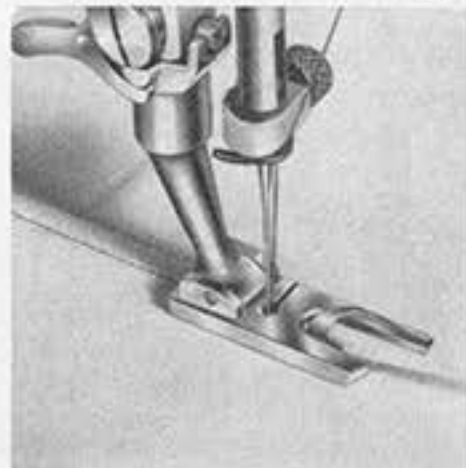

Fig. 22

## Gathering foot

(Available as an extra)

Lay the material to be gathered under the gathering foot, that is to say not in the transverse slot. Lower the gathering foot by means of the presser foot lever and insert the piece of material, which must remain quite flat, into the transverse slot as far as it will go. If the flat piece of material is held back when sewing, the bottom piece of material will gather, the amount of gathering depending on the amount by which the flat material is held back.

If only one layer of material has to be gathered, lay the material under the gathering foot, onto the feed dog. The material gathers more or less, according as the length of stitch is set larger or smaller.

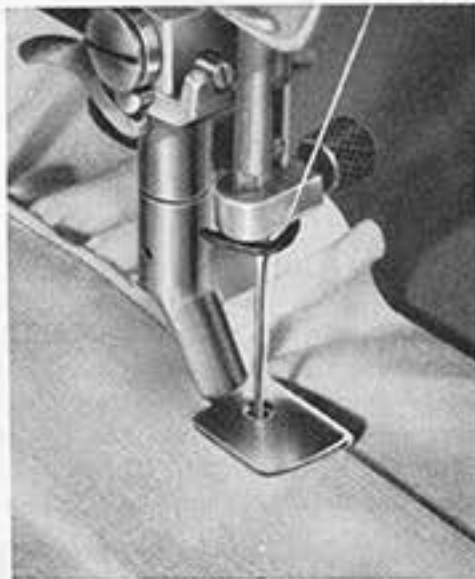

Fig. 23

(Available as extra)

## Edger

As shown by the illustration, the stitch hole is placed adjacent to the right presser foot edge. The foot, without the lateral quitter guide attached, is particularly suitable for edgestitching, facings, collars etc. and inserting zips.

When the adjustable edge guide is attached to the edger, the latter can be used for quilting work as shown in Fig. 24 below.

The guide is first fixed at the desired distance from the edger. Then make a seam and shift the material to the right so that the seam just made is in line with the guide. Then sew a new seam, following the direction of the first seam with the leg of the guide, and so on. Afterwards, repeat the same operations in the transverse direction.

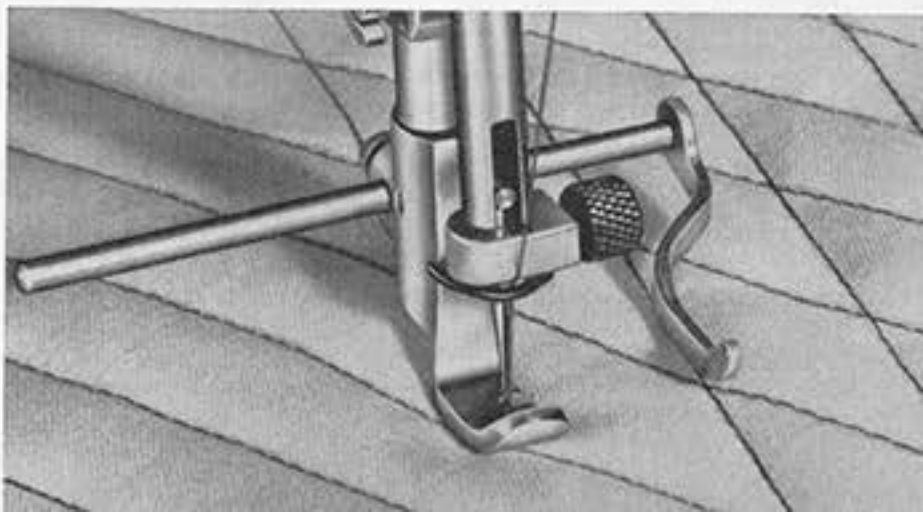

Fig. 24

## Zigzag

### Adjusting the stitch width

On the front of the machine, at the top in the middle, there is the shift knob 9 with scale (Fig. 2) for adjusting the stitch width.

Above the knob a marking is fixed on the machine. For plain sewing, the knob is set so that the marking points to the numeral 0, and therefore a straight stitch can be sewn. If the knob is turned clockwise, the marking on the machine points to one of the numerals from 1 to 4, according to the position of the knob 9. The bigger the number, the more will the needle deflect, i. e. the zigzag stitch widens according to this number.

While sewing zigzag, this knob may be turned to and fro as desired. When the machine is at rest, the knob should only be turned when the needle is raised from the material and is in its highest position.

### Left - middle - right adjustment

Lying over the shift knob 9 (Fig. 2) for the width of the zigzag stitch, there is another handle-lever 10 (Fig. 2). If this lever is set so that the handle points vertically downwards, the needle deflects from the middle uniformly to right and left (Fig. 25 a). If the handle-lever is turned so that the handle points obliquely to the right, the needle deflects from right to left (Fig. 25 b). If the handle-lever is turned so that the handle points obliquely to the left, the needle deflects from left to right (Fig. 25 c). While

sewing, this lever can be set to the middle, left or right as desired. But here also, when the machine is at rest, the lever should only be turned when the needle is out of the material and therefore in its highest position.

The majority of zigzag work is done with middle stitch, whilst lefthand stitch is adopted for sewing on buttons and making ornamental stitches.

The righthand stitch is adopted for other ornamental stitches, and often a combination of these two kinds of stitch is also used.

Fig. 25

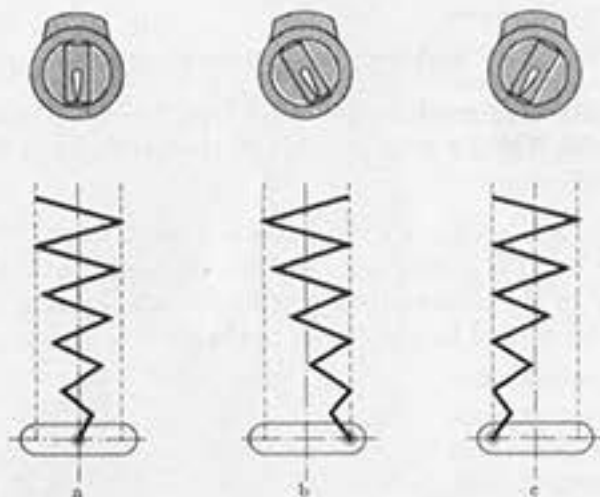

### Zigzag sewing

(Use 2 or 3-ply thread, never 6-ply)

For zigzag sewing set the machine as follows:

1. Set take-up lever 7 (Fig. 2) in approximately its highest position.
2. Insert zigzag foot. Lay top and bottom threads together to the back under the zigzag foot.
3. Adjust drop feed knob 16 to the sewing mark by turning it counterclockwise.
4. Adjust stitch length lever 14 so that the zero mark of the stitch length scale is somewhat below the line mark at the right. This is only possible if the screw 14 is not completely screwed in.
5. Turn zigzag shift knob 9 clockwise in accordance with the desired width (0-4). The more it is turned clockwise, the wider will the zigzag seam be. The zigzag knob should never be operated when the needle is in the material and the machine is at rest. On the other hand, the zigzag knob may be turned to and fro as desired while sewing.
6. Slide the sewing table on.

## Elastic Sewing of Knitted Goods

Knitted goods can be mended in a variety of ways; two of the most usual are described below:

Fig. 26 a



Alternative 1: Cut the mending patch to the desired shape and size and then place it *into* the damaged place in line with the direction of the loops, the underside of both pieces facing upwards, and sew them to each other. Then sew over the cut edge of the patch zigzag stitch (stitch length 1 and stitch width 3 or 4). Parallel to this first seam and inside it, a second zigzag seam is sewn at a distance away of approx.  $\frac{1}{4}$ ". Finally, cut the damaged part of the fabric along the inner seam and remove the basting stitches.

Alternative 2: Lay the mending patch *under* the damaged portion of the fabric with the loops in line (Fig. 26a), the underside of both sections facing upwards, and sew the patch on (Fig. 26b).

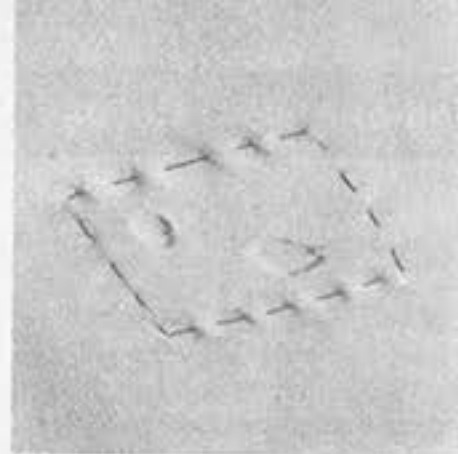

Now sew a zigzag seam along the basting stitches (Fig. 26c), using stitch length 1 and stitch width 3 or 4, and a second zigzag seam at a distance away of approx.  $\frac{1}{8}$ ". Then cut the damaged portion of the fabric out along the inner seam, and trim the projecting edge of the patch below along the outer seam. Finally remove the basting.

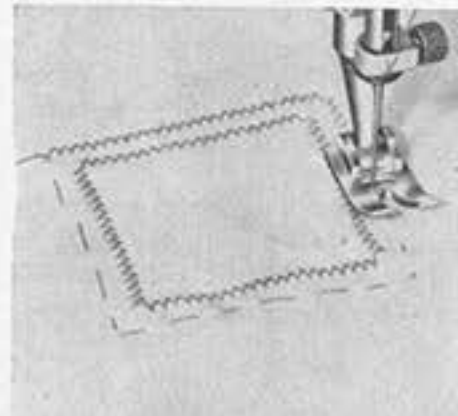

#### Sewing-on lace

To sew-on lace, use as a rule a short stitch length and a narrow stitch width. Normally the stitch length lever 14 (Fig. 2) is set at 1 and the zigzag knob 9 to 1-2. Place the lace on the material so as to overlap by about  $\frac{1}{8}$ ", thus facilitating the sewing on. Now attach the lace by zigzag stitches, and cut off the projecting edge of the material along the zigzag seam.

## Roll Hemmer

(Available as extra)

The roll hemmer, distinguished by two red lines on its shank, is similar in shape to the ordinary hemmer, but is provided with a stitch hole that is not circular but oblong, so that zigzag seams can be sewn. The roll hemmer is operated in the same manner as the ordinary hemmer. The zigzag control knob 9 (Fig. 2) is set at approx. 3-4. Roll hems are used particularly for edging fine material.

#### Shell roll hem

The roll hemmer is also used for making shell roll hems. The cloth or knitted fabric is inserted in the spiral guide tongue as for roll hemming. The zigzag stitch bridges the entire seam. Tight top-thread tension and big stitch length produce the shell-like effect. The shell roll hem is used mainly for edging knitted underwear.

Fig. 27

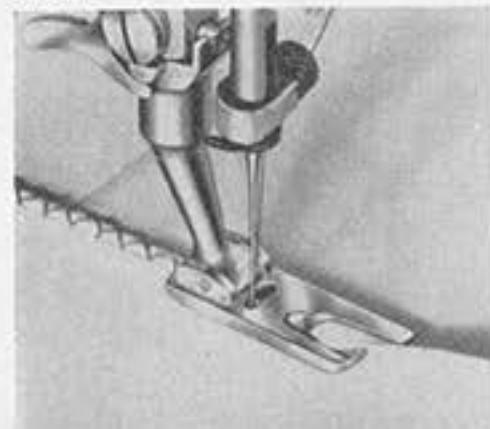

## Braiding

(with embroidering foot, available as extra)

Insert a soft cord in the guide hole of the zigzag embroidering foot, which is marked by 1 red line on its shank, and stitch or embroider over with zigzag stitches. Use mercerized thread 50/2 or 60/2. A variety of effects can be obtained with this stitch. - The effect can also be enhanced with coloured thread, coloured cord, several rows of seams beside each other, etc., etc.

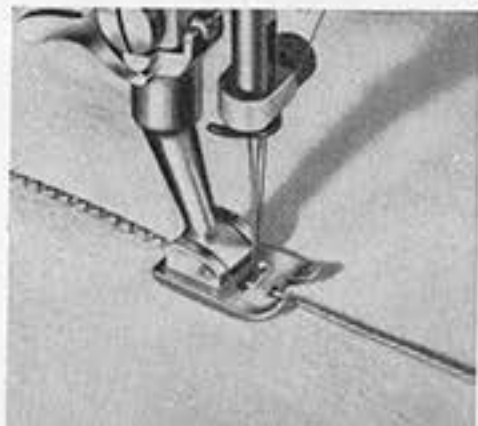
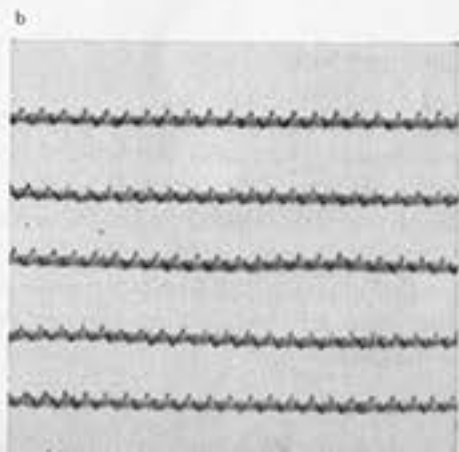

Fig. 28



## Buttonhole Sewing

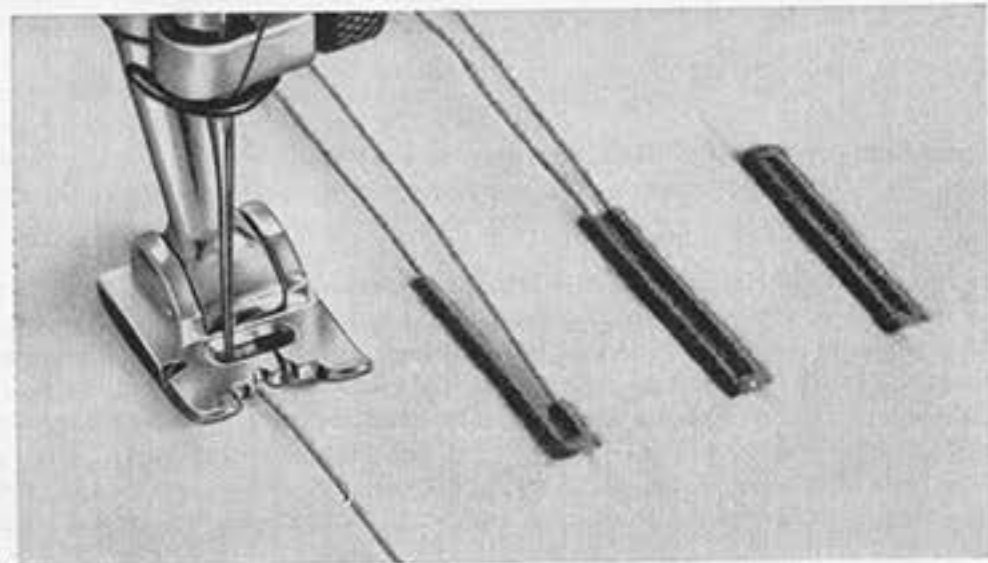

Fig. 29

## Buttonhole sewing

There are three types of buttonholes:

- a) Ordinary buttonholes,
- b) Braided buttonholes,
- c) Raised buttonholes.

Types a) and b) are made with normal thread tension.

For *braided buttonholes* use a soft cord and insert it into the guide of the buttonhole foot (marked with 3 black lines). In other respects the procedure is the same as with ordinary buttonholes.

A raised buttonhole is obtained when the tension of the bottom thread is quite slack. In order to determine the proper tension, make use of the threaded bobbin case; take hold of the projecting thread and let the bobbin case hang on it. If the case causes the thread to unwind by its own weight, i. e. if the case descends easily, the tension is good. On the other hand, the top thread tension must be so strong that the *bottom thread* appears quite flat on the upper side of the material. For raised buttonholes it is absolutely necessary to use unglazed 6-ply thread No. 40 as top thread, whilst quite a fine thread is needed for the bobbin (60/2). In colour work, for raised buttonholes the coloured two-ply thread must be wound on the bobbin.

## Sewing a buttonhole

1. Insert the buttonhole presser foot; it is distinguished by 3 black lines on its shank.
2. Set needle to enter at *the left* by moving handle-lever 10 to the left (Fig. 2).
3. Set zigzag control knob 9 (Fig. 2) to 1.5-1.7. When sewing a buttonhole on *knitted wear* select stitch width 2.
4. Set stitch length lever 14 so that the zero line of the stitch length scale lies somewhat below the line marked at its right.
5. Now sew the first bead corresponding to the desired length of the buttonhole. The last needle hole of the finished bead must be *at the right*, whereby the needle is inserted only  $\frac{1}{12}$ " into the material.
6. Raise the presser foot, and turn the material through 180° clockwise. Then lower the presser foot again and allow the



Last  
stitch  
on right



Allow  
needle  
to enter  
on left



Last  
stitch  
on left

needle to enter the material *at the left*. Again just let the point of the needle enter the material.

7. Set zigzag control knob 9 to 3.5 and sew a few end stitches. Pull the material towards you slightly, in order to shorten the feed.

Last needle hole *at the left*. Only the point of the needle into the material.



Last  
stitch  
on left



Last  
stitch  
on left

8. Set the zigzag knob 9 again to 1.5-1.7 and sew the second bead somewhat shorter than the first one.

Last needle hole *at the left*.

9. Set zigzag knob again to twice the bead width and sew the end stitches. Again pull the material somewhat back to shorten the feed.

Last needle hole *at the left*.

10. After that, set zigzag knob 9 to zero and sew a few fastening stitches, again pulling the material lightly towards you in order to shorten the feed.

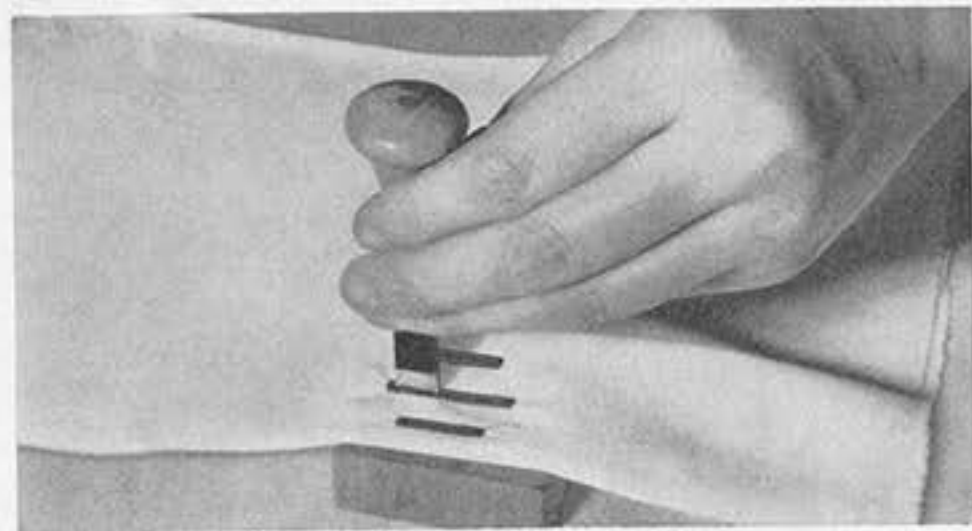

Fig. 30

11. Finally place the work on the wooden block and pierce the material between the two beads with the buttonhole cutter.



## Sewing on Buttons

(Button presser foot available as extra)

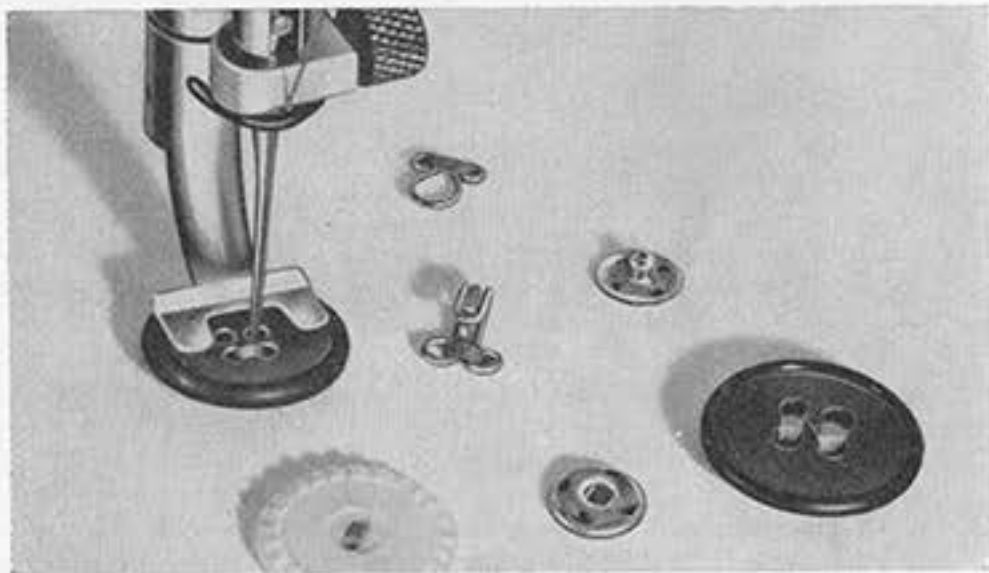

Fig. 31

1. Position the needle to stitch to *left*.
2. Lower the feed dog by turning drop feed knob 16 (Fig. 2) clockwise until darning symbol appears.
3. Insert button presser foot, distinguished by 2 black lines on its shank, and place the button under the foot, as in Fig. 31.
4. Adjust zigzag stitch width according to the distance between the stitch holes in the button and sew button on with 6-8 stitches.
5. When fastening the stitches, leave needle always in one hole of the button. Set zigzag knob 9 (Fig. 2) to zero and fasten with several stitches.

With four-hole buttons, shift the cloth with the button and sew 6-8 stitches also in the second pair of holes. Press-studs and hooks are sewn on in the same manner.

## Darning with wool

(Wool-darning foot available as extra)

Fig. 22 a



When darning with wool, use the wool-darning foot. Proceed as follows:

1. Lower the feed dog. See page 27 or 28)
2. Set stitch regulator 14 (Fig. 2) to zero, thus preventing the lowered feed dog from being operated unnecessarily.
3. Set zigzag knob 9 (Fig. 2) to 3-4.

For top and bottom threads, use darning thread. Wool is employed to cover the

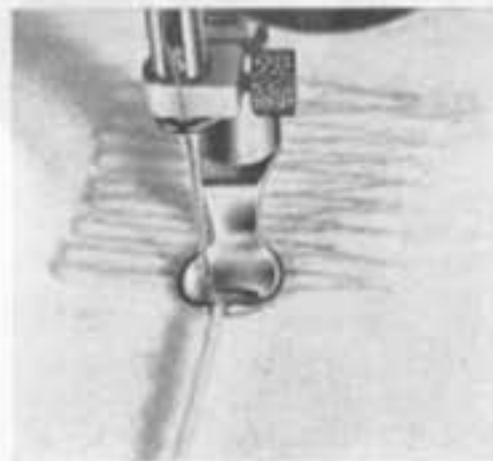

Fig. 22



damaged area. Choose top and bottom threads and darning wool of a colour corresponding to the piece to be mended, so that the darn is as invisible as possible. The thread tension is the same as in ordinary darning.

Woolen socks are pulled over the free arm, and the darning ring is then not used.

Darning with wool is performed in two stages:

1. Cover the damaged area with rows of wool.
2. Sew these rows down.

In the three illustrations, Fig. 32 a, b and c, the darning operation is clearly shown. As can be seen from Fig. 32 a, the wool is inserted in the slot of the foot, and the thread end allowed to project about  $\frac{1}{2}$  inch over the rear edge of the foot. Now span the hole with wool as shown in Fig. b. Start at the lefthand top corner of the damaged area and lay one row beside the other sideways, i. e. from left to right and viceversa, by moving the darned material to and fro accordingly. At the end of each row, the zigzag stitch tacks the wool to the fabric when the direction of movement is changed. Make sure that the rows lie as close as possible to each other, because no more wool will be used later. As soon as the hole is quite spanned with wool, cut the wool thread at the darning foot. Now fasten the wool rows with zigzag stitches across them as shown in Fig. c, by shifting the fabric forwards and backwards. Zigzag stitch is employed to ensure that the mend remains elastic, and care should be taken not to place the zigzag rows too close together.



Fig. 33

## Applique Work

(Needle displaced to left)

An attractive decorative effect is obtained by sewing cut-outs of cloth or tulle of different colours onto the workpiece. Appliqué work is employed mainly on collars, ladies' and children's dresses, linen, and the like.

For this work, it is best to use the buttonhole presser foot.

First print the drawing on the *underside* of the material. The fabric from which the designs are cut should be of a pleasant contrasting colour. Cut the piece slightly larger than required by the drawing and baste it onto the *upperside* of the material, i. e. not on the side with the drawing. Then, at the underside, sew a narrow ( $\frac{1}{2}$ -1) zigzag stitch row (stitch not too short) along the lines of the drawing. The sewing thread should agree in colour with the applied fabric. Then remove the basting and trim along the sewing line on the upper side. Now finish the work by sewing a wider ( $2\frac{1}{2}$ ), short zigzag stitch line over the edges of the cut-out, this time on the upperside of the material.

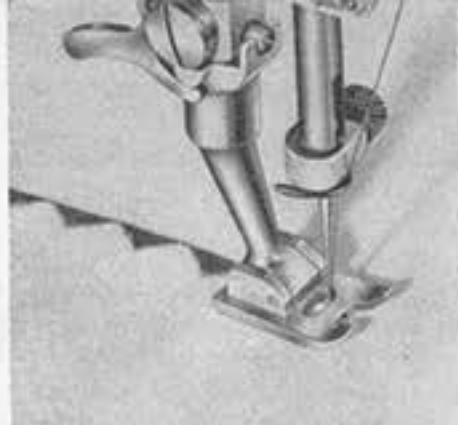

Zigzag embroidering foot (1 red line)

Zigzag sewing foot

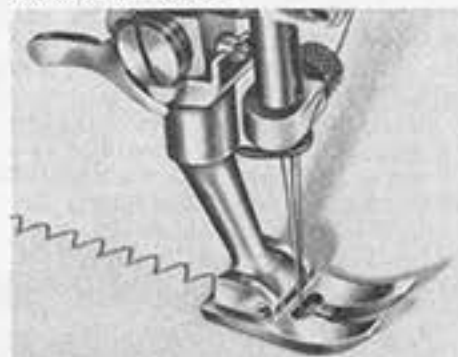

Fig. 34

## Ornamental stitches

(Sewing foot only available as extra)

### The zigzag ornamental stitch

With the Bernina Zigzag Sewing Machine, Model 600 and Model 610, a great variety of ornamental stitches can be produced in the simplest manner imaginable. Depending on the ornamental stitch desired, the stitch regulating lever 14 (Fig. 2) is more or less depressed, and the zigzag knob 9 is turned to and fro during sewing. After a few experimental stitches, the sewing of ornamental stitches becomes easy.

For ornamental stitches of normal stitch length (sample *a* in Fig. 36), use the zigzag sewing foot (Fig. 35). For stitches of very short length (sample *b* in Fig. 36), use the zigzag embroidering foot (Fig. 34). The latter has a recessed lower face.

Fig. 35



Fig. 36

Needle position

combined

right

middle

left

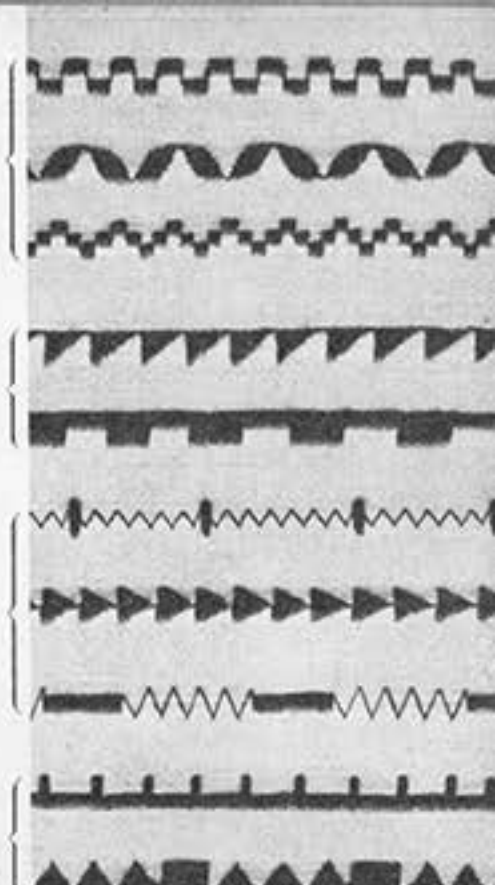

Fig. 37

a = normal stitch length, zigzag sewing foot

b = short stitch length, zigzag embroidering foot (1 red line)

} Page 61

### Zigzag ornamental stitches and their combinations

As seen from the foregoing descriptions, zigzag stitches are the result of the combination of

1. Stitch length (fabric feed) from zero to 4 mm
2. Stitch width (needle throw) from zero to 4 mm
3. Stitch location (deflection left-middle-right).

Ornamental stitches are produced by suitable adjustment of the control knobs during the sewing.

Stitch location	centre						
Stitch width	1	1,5	2	2,5	3	3,5	4
Stitch length 1							

Fig. 38



Stitch length 2



Stitch length 3



Stitch length 4



Stitch length approx. zero



When sewing with adjusted stitch length and stitch width, the accompanying designs are produced:

Naturally, all intermediate values for stitch width and also for stitch length may be used as well.

By altering the stitch length, stitch width and needle position, the following and other varieties of sewing are produced:

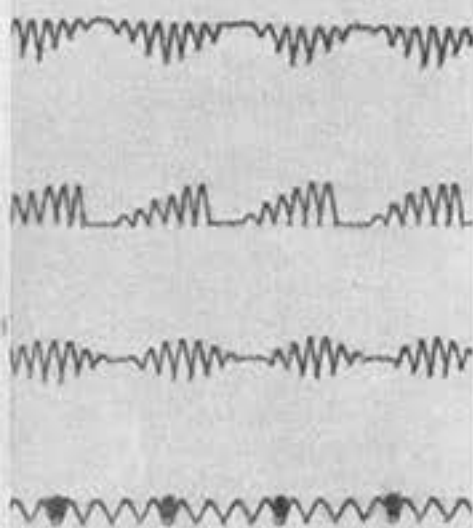

Stitch length  
Stitch width  
Stitch location

1  
2  
centre  
centre  
left  
right

Fig. 39

Length approx. zero  
Width 0-4  
Locat. left

1 1/2-3  
1 1/2-4  
1 1/2-4  
1 1/2-4  
1 1/2-3  
4

Fig. 40

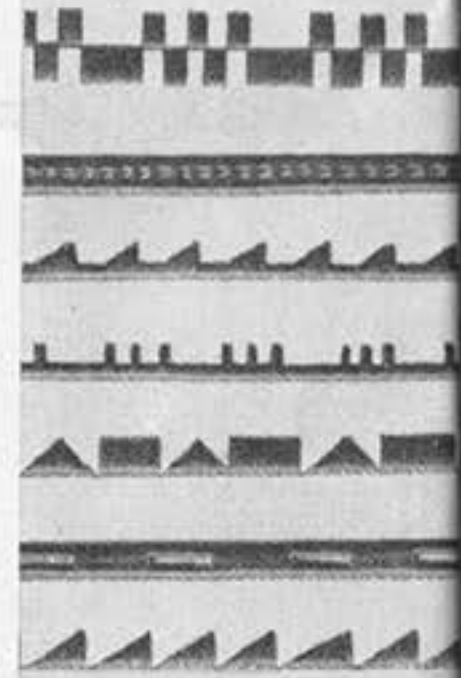

Stitch length almost zero  
Width 1 1/2-4 0-4  
4 4-0  
4 4

1 1/2 1 1/2 1 1/2 1 1/2 1 1/2  
0-4 0-4 0-4 0-4 0-4  
C C C C C  
C C C C C

Fig. 41

Stitch length almost zero  
Width 4-1 1/2 4  
4 0-4  
1 1/2-4 4-0

4 4-1 1/2 4  
0-4 4-0 4-0 4-0  
R R R R R

Fig. 42

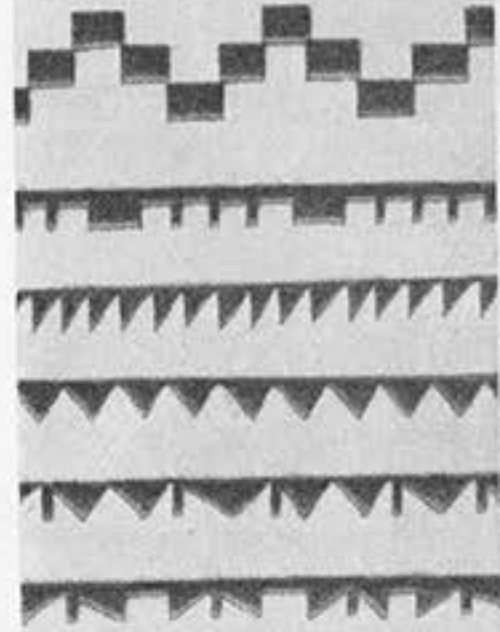

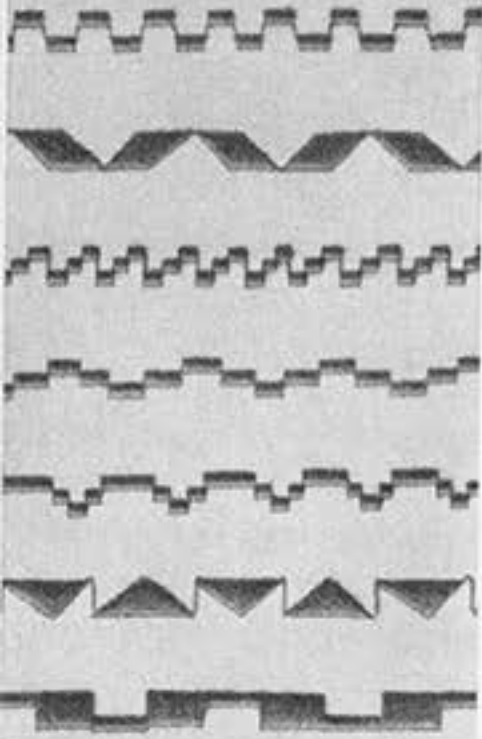

Stitch length almost zero

Width  $\left\{ \begin{array}{l} 1\frac{1}{2}-4 \\ 4 \end{array} \right.$  0-4  
4-0 LR

Locat. LR

Fig. 43

$1\frac{1}{2}$  LR

0-4 LR  
4-0 LR

$1\frac{1}{2}$  LCR

$1\frac{1}{2}$  LCR

$1\frac{1}{2}$  LCR

$1\frac{1}{2}$  LCR

2 Needles

Stitch length 1 1

Stitch width 1 1

Stitch location C C

1 1 LR

$1\frac{1}{2}$  LR

$1\frac{1}{2}$  C

$1\frac{1}{2}$  C

$1\frac{1}{2}$  C

$1\frac{1}{2}$  C

$1\frac{1}{2}$  C

$1\frac{1}{2}$  C

Fig. 44

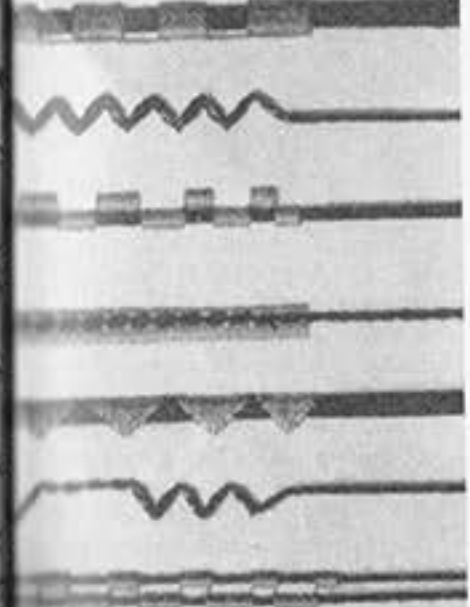
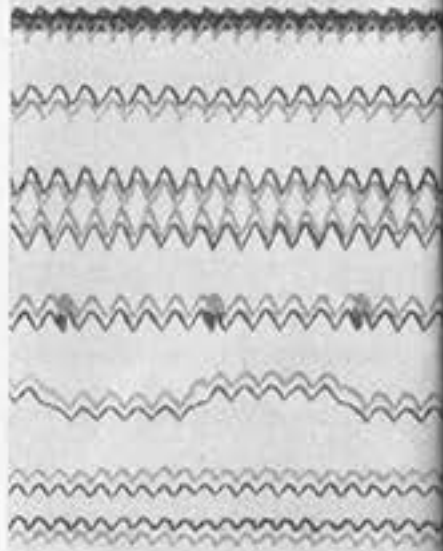

Stitch length almost 0 2

Stitch width  $1\frac{1}{2}$  0-4

Stitch location LR R

almost 0

0-4 4-0 4

$1\frac{1}{2}$  R

$1\frac{1}{2}$  C

$1\frac{1}{2}$  L

2 4 L

almost 0

$1\frac{1}{2}-4$  C

almost 0

$1\frac{1}{2}$  LR

Fig. 45

Stitch length 1 alm. 0 1

Stitch width  $\frac{1}{2}-4$  4-0  $1\frac{1}{2}-4$

Stitch location R C L

alm. 0

$1\frac{1}{2}$  0  $1\frac{1}{2}$

alm. 0

alm. 0

alm. 0

alm. 0

alm. 0

alm. 0

alm. 0

alm. 0

alm. 0

Fig. 46

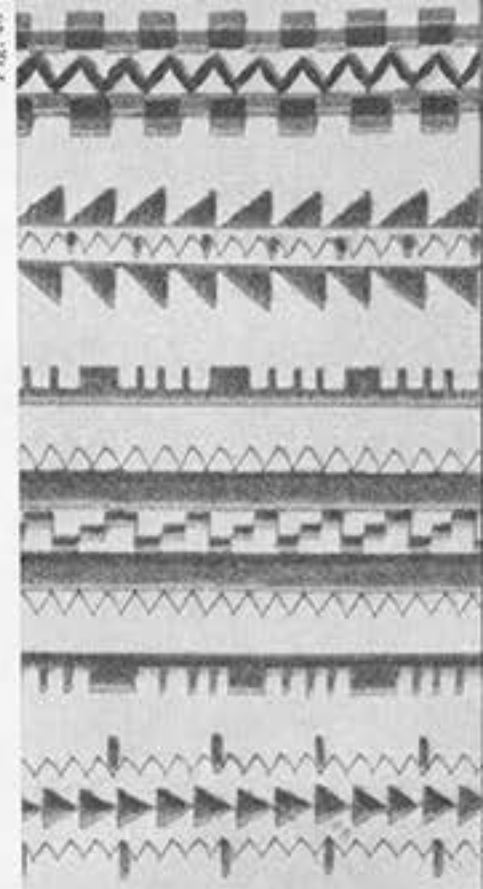

## Feather Stitch (hand operated)

- a) with one needle
- b) with two needles

Stitch length	almost zero	almost zero	almost zero
Stitch width	$2\frac{1}{4}$	$3\frac{1}{2}$	2
Stitch location	C	C	C
	a	a	b



Fig. 47

## Feather stitch

The feather stitch can be produced with one or with two needles. The fabric is held taut in an embroidery frame which is as large as possible, especially if the fabric is a light one. For strong, firm material no fixing in a frame is needed. Begin the trials for this manner of stitching by first sewing a bead seam, i. e. allowing the fabric to be moved along by the machine, and then shifting the embroidering frame alternately to the left or the right, with pivot point round the needle hole. - After a short trial period, the feather stitch can be adopted for all possible kinds of fancy figures.

(Foot and needles  
available as extras)

## Pintucking

The complete pin-tucking attachment comprises the following items:

- 2 double needles for pin-tucks approx.  $\frac{1}{12}$ ,  $\frac{1}{8}$  and  $\frac{1}{6}$  inch wide
- 3 pin-tuckers with 3, 5 and 7 grooves
- 1 pin-tuck threader

When preparing the machine for pin-tucking, proceed as follows:

- 1. Set zigzag knob 7 (Fig. 2) to zero.
- 2. Remove ordinary needle from the needle bar and insert a double needle instead (in the same manner as the normal needle).
- 3. Insert the pin-tucking foot corresponding to the needle distance, namely:
  - foot with 7 grooves / double needle of  $\frac{1}{12}$ "
  - foot with 5 grooves / double needle of  $\frac{1}{8}$ "
  - foot with 3 grooves / double needle of  $\frac{1}{6}$ "



Fig. 48



- 4 Thread tension
- 7 Take-up lever
- 8 Thread guide eyelet
- 22 Spool pins
- 32 Thread guide eyelet
- 33 Needle-holder eyelet

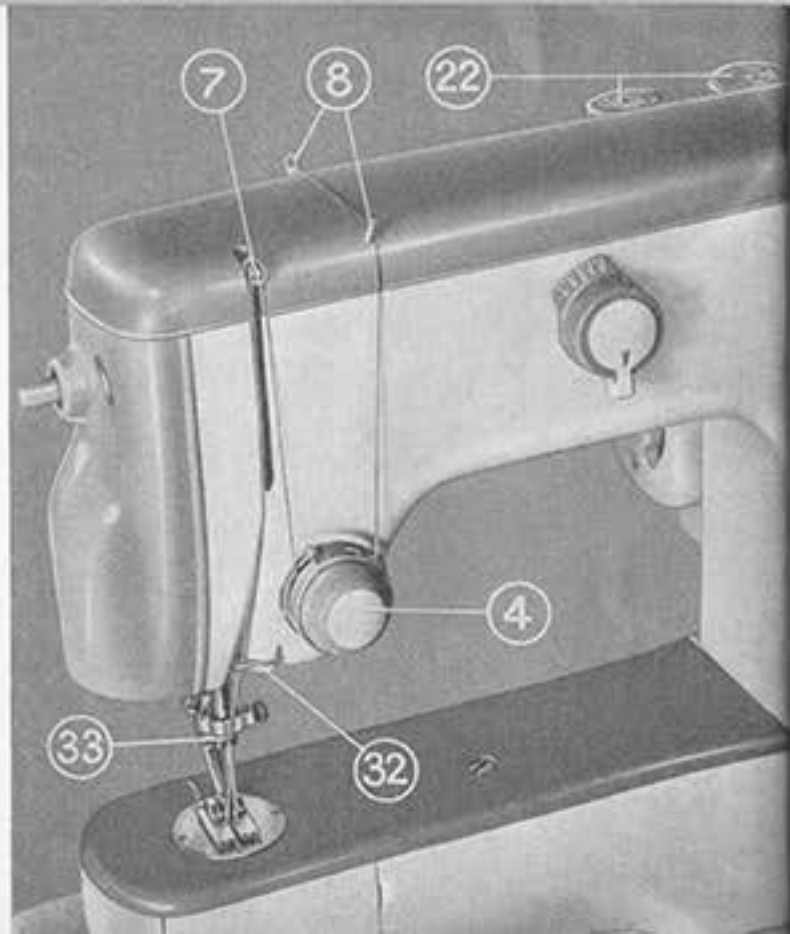

Fig. 49

#### Threading the two top threads Fig. 49

To thread the machine for pin-tucking with two top threads, proceed as for normal sewing. Slip the thread spools onto the double spool holder with the two spool pins 22 at the rear of the machine. Pass the thread of the front spool through the rear eyelet 8 on the top of the stand, hence to the eyelet 8 at the front and from here through the rear thread tension disc, which is separated from the front disc by an intermediate disc. From here pass the thread through the upper hole in the take-up lever 7, down behind the thread guide eyelet 32 on the stand, then into thread guide 33 and finally through the eye of the lefthand needle. The second thread is threaded similarly, but passed through the front thread tensioner to the lower hole in the thread take-up lever 7, and through the eye of the righthand needle.

From the thread tension onwards, the two threads have always to run separate, since better pin-tucks are obtained in that way.

#### Pin-tucking Fig. 50

A pin-tuck is formed by the bottom thread pulling the two top threads together, so that the fabric between the needles is raised into a tuck. For pin-tucks with cord insert, the inserted thread is passed from the ball along the groove on the flap, brought by means of the threading device up through the hole in the throat plate between the two rows of teeth of the feed dog, and passed away from operator below the pin-tucking foot.

### Ornamental stitch with double needle

When using one pin-tucking needle and the ordinary zigzag sewing foot, a parallel double ornamental seam can be produced, the two threads being preferably chosen of different colours.

When using a double needle with  $\frac{1}{12}$  or  $\frac{1}{8}$  inch gap, an additional zigzag motion can be made. The needle deflection, however, should only be so large that neither needle fouls the stitch hole either at the left or at the right. The zigzag knob 9 (Fig. 2) may therefore only be turned slightly to the left from the zero mark.

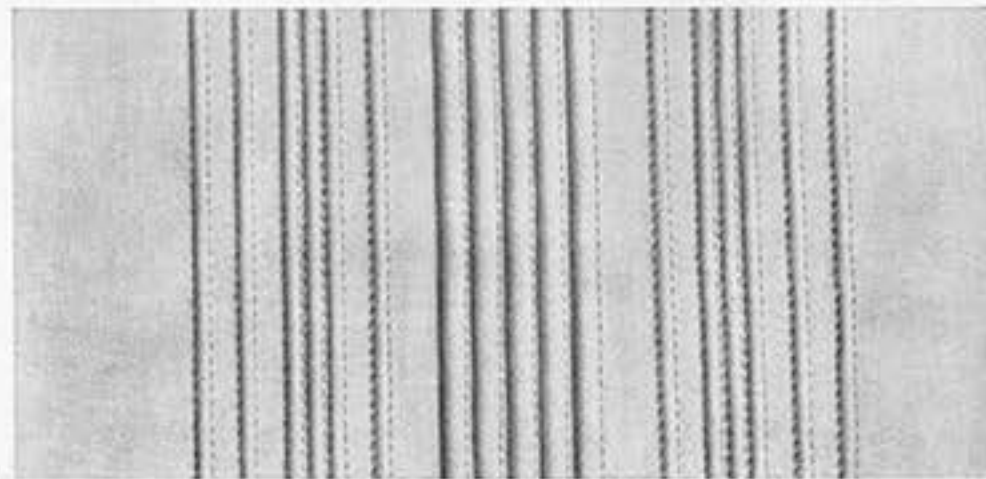

Fig. 50

### Embroidering around holes

(Equipment available as extra)

The complete equipment for embroidering around holes consists of the following components:

- 53 06 62 Hole embroidery foot
- 53 06 60 Needle plate with slide for holes
- 54 12 01-01 Embroidering ring
- 54 11 05 Square piercer
- 54 11 06 Round piercer

This simple device permits sewing fashionable "Broderie anglaise" and circular embroidery on the BERNINA. By its means, holes of various sizes can be sewn round, and circular embroidery made up to about 1 inch in diameter. The stitch width can be varied while sewing round.

For hole embroidering, set the machine as follows:

1. Set needle to left position, by setting the lever 10 (Fig. 2) to the left.
2. Lower the feed dog, control knob 16 (Fig. 16 and 17) being set to the darning symbol.
3. Change the normal needle plate for the hole embroidery needle plate, which is provided with interchangeable slides with guide pins; also insert the special presser foot.

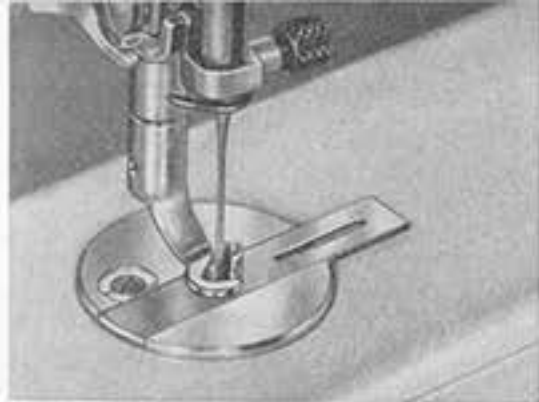

Position of slide  
for hole embroidery

Fig. 51



Embroidering is done  
in the embroidery  
frame

Fig. 52

Always use the embroidery frame. We recommend winding strips of cloth round its outer ring in order to obtain better tension of the material and to avoid damaging it. Only after clamping the material in such a manner, punch the holes with the piercers supplied. It will be of advantage to mark the holes previously on the material with a pencil or the like. Then lay the material under the hole embroidery foot so that the guide pin



Position of slide for  
circular embroidery

Fig. 53



of the slide projects through the hole. As already mentioned, the needle must be set to the left (page 43, Fig. 25 c).

For top and bottom threads, use embroidery thread No. 60-80, 2-ply, in order to obtain uniform sewing round the holes.

For hole embroidery the thread tension is of great importance. The tension of the bottom thread should be somewhat greater than that of the top thread, so that the thread loops will only show on the underside of the material.

The slide in the embroidery plate has to be set so that the needle, when effecting a righthand stitch, enters the recess of the guide pin just beyond the edge of the material.

This setting alters according to stitch width, and has therefore to be repeated occasionally. Then allow the machine to operate at regular speed, at the same time turning the embroidery ring three or four times clockwise round the guide pin, also in a regular manner.

At the finish, set the zigzag knob 9 (Fig. 2) to zero, and secure the thread with a few stitches. These should be parallel to the threads of the embroidery stitches, so that they remain practically invisible.

When the slide of the embroidery plate is reversed, as shown in Fig. 53, the guide pin can be used as a centre in sewing circular embroidery. The needle stitches through the oblong slot of the slide. By changing the density of the stitches, i. e. by varying the speed of rotation of the embroidery ring during the stitching, and by using threads of different colours, very attractive and varied patterns can be produced.

When embroidering around holes, observe the general rule that holes of the same size should always be finished successively, so that the slide need not be changed too frequently.

## Useful Hints

### Causes and elimination of slight troubles

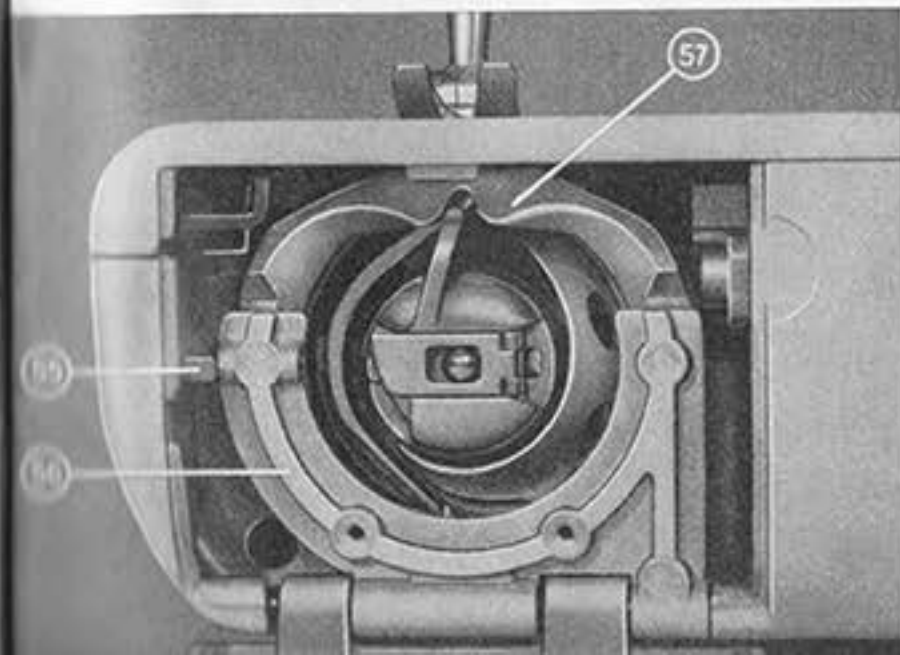

If the machine fails to run either forwards or in reverse, or if an abnormally loud noise is heard, a thread has become jammed in the shuttle race because of faulty manipulation. In such cases, the race can easily be opened and cleaned. Raise the needle bar into its highest position, depress with the thumb of the left hand the spring lever 55 (at

Fig. 54

the left of the shuttle race), so that the locking bridge 56 can be swivelled down together with the shuttle race cover 57. After taking out the bobbin case and shuttle, the jammed thread ends and any dust can easily be brushed out of the shuttle race. Do not use hard instruments, such as screwdrivers, etc., otherwise the shuttle race might get damaged. When the cleaning is finished, first replace the shuttle, then close the locking bridge 56 together with the shuttle race cover 57, and finally insert the bobbin case. Make sure that the locking bridge is properly engaged.

#### **Top thread breakage**

Needle of inferior quality, badly polished needle.

Needle not properly inserted. Long groove must face to the front.

Needle is blunt, or bent.

Needle is too fine in relation to the thread used.

Top thread tension is too tight. Thread control spring is broken.

Needle hole in throat plate damaged by needle; must be repolished.

Shuttle point has become too sharp by needle action. (Call mechanic)

Shuttle race is not oiled.

Inferior thread, or thread with knots.

Thread has dried out because of long storage. Thread should never be kept in heated rooms.

#### **Bottom thread breakage**

Bottom thread tension too strong. Bottom thread has been badly wound.

Bobbin squeezed out of shape, or jams in the case for some other reason.

Needle hole in throat plate damaged by needle; must be repolished.

#### **Faulty stitches**

Unsuitable needle. Use only needles System 705.

Needle blunt or bent.

Needle not properly inserted. Long groove must face to the front. Push needle as far as it can go.

Inferior, badly polished needle.

Cheap needles often tear the thread and break easily. This may cause costly damage to throat plate and feed dog. The best needle is therefore the cheapest in service.

Needle not in correct relation to thread number.

#### **Needle breakage**

Needle is too fine in relation to thread number. Needle is bent.

Needle fixing screw is insufficiently tight.

Top thread tension is insufficient.

Top thread tension is too strong.

If the work is pulled out *towards the operator* when completed, it will often happen that the needle is bent. Then, at the very next stitch, the needle knocks on the throat plate and breaks. Therefore always pull the work away from you *towards the back* from under the presser foot.

During sewing, however, the work should *not be pulled too hard* towards the back.

Using cheap thread, which is unevenly twisted or is even knotty. *One single knot* on a thread reel may break the needle and even, under certain conditions, damage the throat plate, so that the cost of repairs may be very much greater than the extra cost of a first-class thread.

## THREAD CUTTER

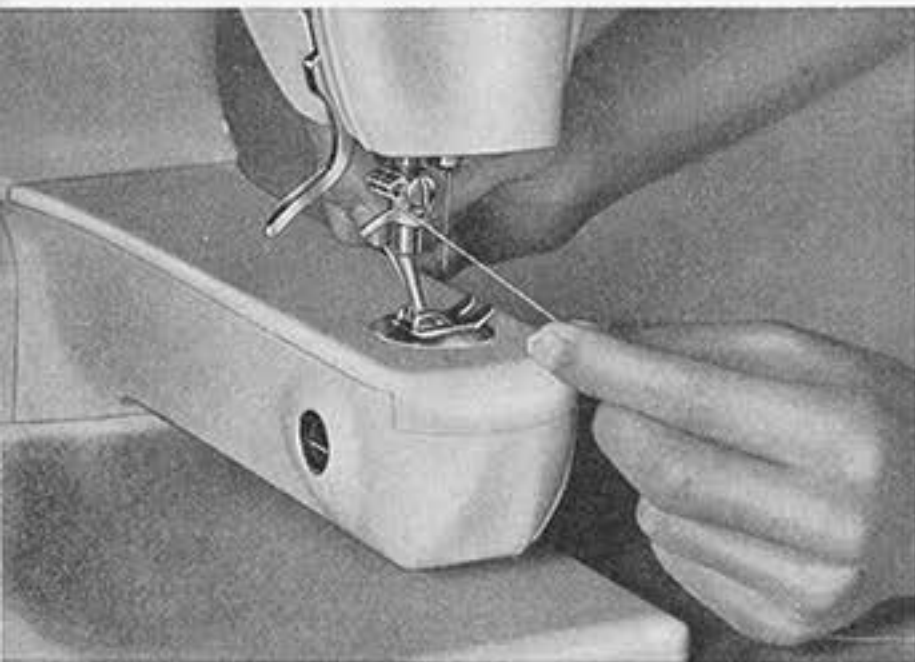

On the BERNINA sewing machine the tension lever of the presser foot is designed in such a way that it can also be used as thread cutter. (See accompanying illustration.)

This little device helps to save much time, especially if a pair of scissors is not available at the moment.

Fig. 55

### Slow operation of the machine

Machine (not the motor) is insufficiently oiled. Thread ends in the shuttle race. Machine is blocked by resinified oil. In that case, flush the machine with kerosene and then oil it again. In stubborn cases of resinification, the machine must be dismantled. If the machine has been standing in a cold room, it should be placed in a warm room about an hour before being used, so that it can assume the room temperature and the oil in the bearings thus becomes liquid again.

### Work puckers

In most cases this is caused by excessive tension in relation to the type of work. When sewing knitted wear, never pull the work away from you with your hands, since that will cause the work to pucker. On the contrary, it is better to push the knitted wear by the hands while sewing.

### General observations

To prevent damaging the presser foot, lay a piece of cloth under it whenever practicable. Do this also whenever the machine is out of use.

*We reserve the right to make alterations at any time in the design as illustrated in the figures and described in the text, without notice and without incurring any obligations.*

Remarks of the BERNINA Agent concerning instructions, home visits  
and eventual guarantee work

Date	Remarks

Notes:

---

---

---

---

---

---

---

---

---

---

---

---

---

---

---

---

---

---

---

---

---

---

---

---

## Notes:

## Standard Accessories for Models 600 and 610

Part No.			
60 11 03 00	<i>In the accessories box:</i>	60 00 55 00	<i>In carrying case:</i>
63 06 03 04	1 zigzag presser foot with hinged base	60 10 60 00	1 slide-on-table
63 06 70 00	1 darning foot		1 foot-starter, with cables for motor and mains
63 06 18 01	1 buttonhole foot	53 11 10 00	1 Instruction Book
63 06 85 00	Zigzag embroidery foot (also used for branding) with edge guide		1 cable for connecting to mains, with plastic sack (only in the case of Model 610 with foot starter)
63 06 08 00	Wide hemmer		<i>Invoiced as extras:</i>
63 11 34 00	1 buttonhole cutter	53 06 13 00	Lap hemmer
63 11 87 00	1 wooden block	53 06 46 00	Gathering foot
63 12 00 02	1 darning attachment for stockings	53 06 48 00	Narrow hemmer
63 07 01 00	4 bobbins, one of them in the machine	53 06 15 00	Edger with quilting guide
63 11 32 00	1 screwdriver, small	53 06 11 00	Roll and shell-roll hemmer, combined
60 11 03 00	1 special screwdriver	53 06 20 00	Button presser foot
63 11 12 00	1 plastic oiler	53 06 29 00	Wool darning foot
63 11 28 00	1 brush	53 06 44 01	Plain stitch presser foot
	1 assortment of 4 needles, System 705	53 06 36 00	Pin-tucker foot with 7 grooves
			Pin-tucking needles $\frac{1}{16}$ , $\frac{1}{8}$ and $\frac{1}{4}$ inch / Equipment for embroidering around holes



Fritz Gegauf Ltd.  
BERNINA Sewing Machine Factory  
Steckborri - Switzerland

