



BERNINA 770 QE  
ANNIVERSARY EDITION

125  
YEARS



*made to create*

**BERNINA**



# LOOKING FOR A NEW SEWING PROJECT?

You can find what you want in "inspiration", our sewing magazine. Thanks to great sewing patterns and detailed sewing instructions, every project succeeds right away.

Inspiration magazine  
is available in German, English,  
French and Dutch



\* Not available in all countries.



## Edition notice

### Graphics

[www.sculpt.ch](http://www.sculpt.ch)

### Text, Setting and Layout

BERNINA International AG

### Photos

Patrice Heilmann, Winterthur

### Part number

2015/01 en 036040.50.04

1st Edition

### Copyright

2014 BERNINA International AG

**All rights reserved:** For technical reasons and for the purpose of product improvements, changes concerning the features of the machine can be made at any time and without advance notice. The supplied accessory can vary depending on the country of delivery.





# Contents

<b>IMPORTANT SAFETY INSTRUCTIONS</b>	<b>13</b>
<b>1 My BERNINA</b>	<b>16</b>
1.1 Introduction	16
1.2 Further information	16
1.3 Key to signs	16
1.4 Overview	17
Overview front controls	17
Overview front	18
Overview sideways	19
Overview back	20
1.5 Included accessories	21
Use of the power cable (USA/Canada only)	22
Foot control (USA/Canada only)	23
Presser feet	23
Accessory box	24
1.6 Overview Selection Menu on the left (External Functions/Views)	25
1.7 Overview Selection Menu below (System settings)	25
1.8 Buttons and icons	25
1.9 Needle, Thread, Fabric	26
Thread selection	28
Example for needle description	28
Needle/thread combination	28
<b>2 Sewing preparation</b>	<b>30</b>
2.1 Accessory box	30
Accessory box free standing	30
Storing accessories	30
2.2 Connection and Switching on	31
Connecting the foot control	31
Connecting the machine	31
Attaching the lever of the Free Hand System	32
Fixing the touchscreen pen	32
Switching the machine on	32
2.3 Foot control	32
Sewing speed control	32
Raising/Lowering the needle	33
2.4 Spool holder	33
Installing the spool holder	33
Inserting foam pads	34
Positioning the spool disc	34
Using a spool net	34
2.5 Free arm	35
Adjusting the feed dog	35
Using the slide-on table	35
2.6 Presser foot	36

	Adjusting the presser position via the lever of the Free Hand System .....	36
	Adjusting the presser foot position via the button Presser foot up/down .....	36
	Changing the presser foot .....	36
	Displaying the presser foot .....	37
	Adjusting the presser foot pressure .....	37
2.7	Adjusting the feed dog .....	38
2.8	Checking the filling level of the bobbin thread .....	38
2.9	Needle and stitch plate .....	38
	Adjusting the needle position up/down .....	38
	Adjusting the needle position left/right .....	38
	Needle stop up/down (permanent) .....	38
	Changing the needle .....	39
	Selecting the needle .....	39
	Select the needle type and the needle size .....	39
	Changing the stitch plate .....	40
	Selecting the stitch plate .....	40
2.10	Threading .....	41
	Threading preparation .....	41
	Threading the upper thread .....	41
	Threading the double needle .....	44
	Threading the triple needle .....	45
	Winding the bobbin thread .....	45
	Threading the bobbin thread .....	46
2.11	Calling up the Tutorial .....	49
2.12	Calling up the Help .....	49
2.13	Calling up the Creative Consultant .....	49
<b>3</b>	<b>Setup-Program .....</b>	<b>50</b>
3.1	Sewing settings .....	50
	Adjusting the upper thread tension .....	50
	Adjusting the maximum sewing speed .....	50
	Programming the securing stitches .....	50
	Adjusting the hovering height of the presser foot .....	50
	Programming the button «Pattern end» .....	51
	Programming the button «Thread cutter» .....	51
	Adjusting the presser foot position with needle stop down .....	52
	Programming the button «Quick reverse» .....	52
	Programming the foot control .....	53
3.2	Embroidery settings .....	54
	Adjusting the upper thread tension .....	54
	Adjusting the maximum embroidering speed .....	54
	Calibrating the hoop .....	54
	Entering the fabric thickness .....	55
	Deactivating securing stitches .....	55
	Deactivating the thread catcher .....	55
	Programming the automatic thread cut .....	56
3.3	Selecting personal settings .....	56
3.4	Monitoring functions .....	57
	Activating the upper thread indicator .....	57





	Activating the bobbin thread indicator.....	57
3.5	Activating the audio signals.....	58
3.6	Machine settings.....	58
	Selecting a language.....	58
	Adjusting the brightness of the display.....	58
	Adjusting the sewing light.....	59
	Calibrating the display.....	59
	Back to basic setting.....	59
	Deleting user data.....	60
	Deleting data from the BERNINA USB Stick (optional accessory).....	61
	Calibrating the Buttonhole foot No. 3A.....	61
	Updating the software.....	61
	Recovering saved data.....	63
	Cleaning the machine.....	63
	Lubricating the machine.....	63
	Packing the embroidery module.....	64
	Checking the Software Version.....	64
	Reviewing the total number of stitches.....	64
	Registering details of the dealer.....	65
	Saving Service data.....	65
<b>4</b>	<b>Creative sewing.....</b>	<b>67</b>
4.1	Overview Sewing functions.....	67
	Selecting a stitch pattern.....	67
4.2	BERNINA Dual Feed.....	68
	Application of the BERNINA Dual Feed.....	68
4.3	Sewing speed control.....	69
4.4	Editing stitch patterns.....	69
	Changing the stitch width.....	69
	Changing the stitch length.....	70
	Adjusting the upper thread tension.....	70
	Correcting the balance.....	71
	Programming pattern repeat.....	71
	Programming long stitch.....	71
	Mirror image of stitch patterns.....	72
	Editing stitch pattern length.....	72
	Programming the stitch counter function.....	72
	Quick reverse.....	73
	Permanent Quick reverse.....	73
	Backstepping.....	73
4.5	Securing.....	73
	Securing with the button «Pattern end».....	73
	Securing via the icon «Securing».....	73
4.6	Administering stitch patterns.....	74
	Saving settings of stitch patterns.....	74
	Saving stitch patterns in personal memory.....	74
	Overwriting stitch patterns from the personal memory.....	74
	Loading stitch patterns from the personal memory.....	74
	Deleting stitch patterns from the personal memory.....	75
	Canceling alterations.....	75

4.7	Combi mode	75
	Overview Combi mode	75
	Creating Stitch pattern combinations	75
	Saving a stitch pattern combination	76
	Loading a stitch pattern combination	76
	Overwriting a stitch pattern combination	76
	Deleting a stitch pattern combination	76
	Editing a single stitch pattern	77
	Deleting a single stitch pattern	78
	Adding a single stitch pattern	78
	Mirroring a stitch pattern combination	78
	Stitch pattern combination Subdivider 1	79
	Stitch pattern combination Subdivider 2	79
	Securing a stitch pattern combination	79
	Programming pattern repeat	79
4.8	Height Compensation of uneven layers	80
4.9	Sewing Corners	80
4.10	Using eco mode	81
<b>5</b>	<b>Practical stitches</b>	<b>82</b>
5.1	Overview Practical stitches	82
5.2	Sewing straight stitch	84
5.3	Securing with the automatic Securing Program	84
5.4	Sewing in the zipper	85
5.5	Sewing both sides of the zipper from bottom to top	86
5.6	Sewing triple straight stitch	87
5.7	Sewing Triple zig zag	87
5.8	Manual darning	88
5.9	Automatic darning	90
5.10	Reinforced darning, automatic	91
5.11	Finishing edges	91
5.12	Sewing Double overlock	92
5.13	Narrow edgestitching	92
5.14	Wide edgestitching	92
5.15	Edgestitching using the seam guide	93
5.16	Sewing hem edges	93
5.17	Sewing blind hems	94
5.18	Sewing visible hems	95
5.19	Sewing flat joining seams	96
5.20	Sewing basting stitches	96
<b>6</b>	<b>Decorative stitches</b>	<b>97</b>
6.1	Overview Decorative Stitches	97
6.2	Bobbin-Play	98





6.3	Altering the stitch density.....	99
6.4	Sewing cross stitches.....	100
6.5	Pintucks.....	100
	Pintucks.....	100
	Inserting the cord.....	101
	Sewing Pintucks.....	102
<b>7</b>	<b>Alphabets.....</b>	<b>103</b>
7.1	Overview Alphabet.....	103
7.2	Creating lettering.....	103
7.3	Altering font size.....	104
<b>8</b>	<b>Buttonholes.....</b>	<b>105</b>
8.1	Overview Buttonholes.....	105
8.2	Making use of the height compensation tool.....	106
8.3	Using the compensation plate.....	106
8.4	Marking buttonholes.....	107
8.5	Cord.....	108
	Using cord with the Buttonhole foot with slide No. 3A.....	108
	Using cord with the Buttonhole foot No. 3C (optional accessory).....	109
8.6	Sewing a test sample.....	110
8.7	Determining the buttonhole slit width.....	110
8.8	Determining the buttonhole length.....	111
8.9	Using the stitch counter function.....	111
8.10	Sewing a buttonhole automatically.....	112
8.11	Programming the Heirloom buttonhole.....	113
8.12	Sewing the manual 7-step buttonhole.....	113
8.13	Sewing the manual 5-step buttonhole.....	114
8.14	Cutting the buttonhole open with the seam ripper.....	115
8.15	Cutting open buttonholes with the buttonhole cutter (optional accessory).....	115
8.16	Sewing on buttons.....	115
8.17	Sewing eyelets.....	116
<b>9</b>	<b>Quilting.....</b>	<b>117</b>
9.1	Overview Quilt Stitches.....	117
9.2	Sewing in the Quilting securing Program.....	118
9.3	Sewing handlook quilt stitches.....	118
9.4	Guiding the quilt work freely.....	119
<b>10</b>	<b>BERNINA Stitch Regulator (BSR).....</b>	<b>120</b>
10.1	Using the BSR mode.....	120
10.2	BSR mode 1.....	121
10.3	BSR mode 2.....	121
10.4	BSR function with Straight stitch No. 1.....	121

10.5	BSR function with Zig zag No. 2.....	121
10.6	Sewing preparation.....	121
	Attach the BSR presser foot.....	121
	Changing the presser foot sole.....	122
10.7	Securing.....	123
	Securing in BSR1 mode with the button «Start/Stop».....	123
	Securing in BSR2 mode.....	123
<b>11</b>	<b>Embroidery.....</b>	<b>124</b>
11.1	Overview Embroidery module.....	124
11.2	Supplied accessories.....	124
11.3	Important Embroidery information.....	125
	Choosing the embroidery motif.....	125
	Embroidery test.....	125
	The size of the embroidery motif.....	125
	Underlay stitches.....	126
	Satin stitch.....	126
	Step stitch.....	126
	Connecting stitches.....	127
	Upper thread.....	127
	Bobbin thread.....	127
	Tear-away stabilizers.....	128
	Cut-away stabilizers.....	128
11.4	Overview Embroidery functions.....	128
11.5	Embroidering preparation.....	129
	Attaching the Embroidery foot No. 26.....	129
	Selecting the Embroidery foot No. 26.....	129
	Inserting the embroidery needle.....	129
	Selecting the needle.....	130
	Selecting the needle type and the needle size.....	130
	Attaching the stitch plate CutWork/Straight.....	131
	Selecting the stitch plate CutWork/Straight.....	132
	Attaching the Module.....	132
	Preparing the embroidery hoop.....	133
	Using adhesive spray.....	134
	Using spray starch.....	134
	Using iron-on interfacing.....	134
	Using paper-backed adhesive stabilizer.....	134
	Using water-soluble stabilizer.....	135
	Attaching the hoop.....	135
11.6	Selecting an embroidery motif.....	135
11.7	Embroidery hoop.....	137
	Overview Embroidery hoop selection.....	137
	Changing the upper thread in the embroidery mode.....	137
	Changing the bobbin thread in Embroidery mode.....	137
	Sewing with connected embroidery module.....	138
	Activating the grid.....	138
	Locating the center of the embroidery motif.....	138
	Relocating the hoop.....	138







	Practical stitches.....	164
	Buttonholes.....	164
	Decorative stitches.....	165
12.7	Overview Embroidery motifs.....	168
	Editing embroidery motifs.....	168
	Quilt.....	168
	Embellishment.....	171
	Flowers.....	173
	Children.....	175
	Borders and Lace.....	177
	Seasons.....	179
	Hobby/Sports.....	180
	CrystalWork.....	181
	<b>Index.....</b>	<b>183</b>



## IMPORTANT SAFETY INSTRUCTIONS

Please be aware of the following basic safety instructions when using your machine. Before using this machine, read instruction manual carefully.

### DANGER!

To reduce the risk of electrical shock:

- Never leave the machine unattended as long as it is plugged in.
- Always unplug the machine from the electrical outlet immediately after using and before cleaning.

Protection against LED radiation:

- Do not view the LED light directly with optical instruments (e.g. magnifier). The LED light corresponds with protection class 1M.

### WARNING

To reduce the risk of burns, fire, electric shock or injury to persons:

- Use this machine only for purposes as described in this manual.
- Do not use the machine outdoors.
- Do not use this machine as a toy. Close attention is necessary when this machine is used by or near children.
- The machine can be used by children older than 8 or by people with reduced physical, sensory or mental capabilities or if there is a lack of experience and knowledge how to operate the machine as long as they are supervised or have been given instruction concerning the responsible use of the appliance and are aware of the involved risks.
- Children are not allowed to play with this machine.

- Cleaning and maintenance work must not be carried out by children unless they are supervised.
- Never operate this machine if it has a damaged cord or plug, if it is not working properly, if it has been dropped or damaged, or dropped into water. Contact the nearest authorized BERNINA dealer to arrange further details.
- Only use accessories recommended by the manufacturer.
- Don't use this machine when the ventilation openings are blocked. Keep the ventilation openings free from the accumulation of lint, dust and loose cloth.
- Never insert any objects into any openings of the machine.
- Do not operate the machine where aerosol products (sprays) or oxygen are being used.
- Keep fingers away from all moving parts. Special care is required around the sewing needle.
- Neither pull nor push the fabric while sewing. This can cause needle breakage.
- Turn power switch to «0» when making any adjustments in the needle area, such as threading the needle, changing the needle, threading the hook or changing the presser foot.
- Do not use bent needles.
- Always use the original BERNINA stitch plate. The wrong stitch plate can cause needle breakage.
- To disconnect, turn power switch to «0» then remove the plug from the outlet. Do not unplug by pulling the cord, instead grasp the plug to pull it from the outlet.



- Always disconnect the power plug from the electrical outlet when the covers are removed or opened, when the machine is lubricated or during any other maintenance adjustments mentioned in the instruction manual.
- This machine is provided with double insulation (except USA/Canada). Use only identical replacement parts. See instructions for Servicing of double-insulated products.

## Servicing double-insulated products

In a double-insulated product two systems of insulation are provided instead of grounding. No grounding means is provided on a doubleinsulated product, nor should a means for grounding be added to the product. Servicing a double-insulated product requires extreme care and knowledge of the system and should be done only by qualified service personnel. Replacement parts for a double-insulated product must be identical to the original parts in the product. A double-insulated product is marked with the words: «Double Insulation» or «double-insulated».

The symbol may also be marked on the product.

## SAVE THESE INSTRUCTIONS!

### Appropriate use

Your BERNINA machine is conceived and designed for private household use. It answers the purpose to quilt fabrics as it is described in this instruction manual. Any other use is not considered appropriate. BERNINA assumes no liability concerning consequences resulting from an inappropriate usage.



# 1 My BERNINA

## 1.1 Introduction

With your BERNINA 770 QE you can sew, embroider and quilt. Delicate silk or satin fabrics as well as heavy-weight linen, fleece and denim can be sewn successfully with this machine. Numerous practical as well as decorative stitches, buttonholes and embroidery motifs are at your disposal.

In addition to this instruction manual, three help programs are provided on the display.

The **Tutorial** gives information and explanations, covering various aspects of sewing, embroidering and the different stitches.

The **Creative Consultant** provides recommendations for completing your sewing projects. Enter the fabric type and technique desired for the project; the machine provides recommended needle, stitch type and presser foot.

The **Help Program** contains information about individual stitch patterns, functions and applications in the display.

## 1.2 Further information

In addition to this instruction manual for your BERNINA 770 QE the following information products are enclosed:

- DVD with video instruction
- DVD with embroidery motifs
- Accessory catalog

The latest version of your instruction manual as well as additional information in connection with sewing can be found on our website <http://www.bernina.com>

## 1.3 Key to signs

---

 **DANGER** Labels a danger with a high risk which can lead to death or severe injury unless it is avoided.

---

 **WARNING** Labels a danger with a medium risk which can lead to death or severe injury unless it is avoided.

---

 **CAUTION** Labels a danger with a low risk which can lead to light or medium injury unless it is avoided.

---

**NOTICE** Labels a danger which can end up with damage unless it is avoided.

---



**Tips** given by BERNINA **sewing experts** can be found next to this sign.

---

By means of illustration, sample pictures are used in this instruction manual. The machines as well as the accessory shown in the pictures may vary from the delivery content of your machine.

## 1.4 Overview

### Overview front controls



- |   |                      |   |                            |
|---|----------------------|---|----------------------------|
| 1 | Quick reverse        | 6 | Needle up/down             |
| 2 | Thread cutter        | 7 | Upper Multifunctional knob |
| 3 | Presser foot up/down | 8 | Lower Multifunctional knob |
| 4 | Start/Stop           | 9 | Needle left/right          |
| 5 | Pattern end          |   |                            |

### Overview front



- |   |   |    |                                 |
|---|---|----|---------------------------------|
| 1 | Connection for embroidery module              | 8  | Slide speed control             |
| 2 | Bobbin cover                                  | 9  | Thread take-up lever cover      |
| 3 | Connection for accessory (optional accessory) | 10 | Thread take-up lever            |
| 4 | Presser foot                                  | 11 | Clamping screw                  |
| 5 | Needle threader                               | 12 | Connection for slide-on table   |
| 6 | Sewing light                                  | 13 | Connection for Free Hand System |
| 7 | Thread guide                                  |    |                                 |

## Overview sideways



- 1 Connection for foot control
- 2 PC-connection
- 3 Spool pin
- 4 Thread cutter
- 5 Spool holder to be swiveled
- 6 Handwheel

- 7 Power switch
- 8 Connection for power cable
- 9 Magnet holder for touchscreen pen
- 10 Air vents
- 11 USB port
- 12 Feed dog up/down



### Overview back



- |   |   |    |                      |
|---|---|----|----------------------|
| 1 | Connection for slide-on table                 | 9  | Thread pretension    |
| 2 | Connection for darning hoop                   | 10 | Thread take-up lever |
| 3 | BSR connection                                | 11 | Thread guide         |
| 4 | Connection for accessory (optional accessory) | 12 | Clamping screw       |
| 5 | Air vents                                     | 13 | BERNINA Dual Feed    |
| 6 | Thread guide                                  | 14 | Thread cutter        |
| 7 | Bobbin winding unit                           | 15 | Feed dog             |
| 8 | Carrying handle                               | 16 | Stitch plate         |



## 1.5 Included accessories

Visit [www.bernina.com](http://www.bernina.com) for more accessory information.





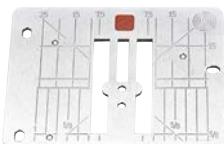















Illustration	Name	Purpose
	Soft Cover with pocket	The soft cover protects from dust and contamination.
	Accessory box	The accessory is stored in the accessory box.
	Presser foot lifter	The presser foot may be raised and lowered with the Free Hand System.
	Slide-on table	The slide-on table increases the sewing surface whereby the area of the free arm is not limited.
	Straight/Cutwork stitch plate	A small stitch hole in the area of the needle allows an optimized stitch entry. This results in a nicer stitch formation.
	3 Spool discs	Spool discs hold the thread spool in place for proper release of thread from the spool.
	3 Bobbins in the accessory, 1 bobbin in the bobbin case	The bobbins are filled with the lower thread.
	2 Foam pads	The foam pad prevents the thread from getting hooked at the spool holder.
	Touchscreen pen	The operation of the display is more precise when using the touchscreen pen instead of the fingers.
	Seam ripper	The seam ripper is an indispensable tool to undo stitches or to cut buttonholes open.

Illustration	Name	Purpose
	Height compensation tool	The height compensation tool levels an angled position of the presser foot sole when sliding over thick seams.
	Selection of needles	The needle assortment contains different versions and sizes of needles for all the common applications.
	Seam guide, right	The seam guide is very useful as a guideline on the right of the needle. It supports the alignment of regular seam distances.
	Screwdriver Torx, gray	Use the gray screwdriver Torx to change the needles.
	Screwdriver red	The red screwdriver is supplied as an all-round tool.
	Angular Torx button	The angular torx screwdriver is used to open the head frame.
	Brush	The brush is used to clean the feed dog and the hook area.
	Lubricator	The lubricator is used to fill up the oil depots.
	Power cable	The power cable connects the machine with the power supply system.
	Foot control	Via the foot control the machine is started and stopped. The speed of the machine is also controlled via the foot control.

### Use of the power cable (USA/Canada only)

The machine has a polarized plug (one blade wider than the other). To reduce the risk of electrical shock, this plug is intended to fit in a polarized outlet only one way. If the plug does not fit fully in the outlet, reverse the plug. If it still does not fit, contact a qualified electrician to install the proper outlet. Do not modify the plug in any way!

## Foot control (USA/Canada only)

Use only foot controller type LV-1 with BERNINA 770 QE.

### Presser feet













Illustration	Number	Name	Purpose	Example
	1C	Reverse pattern foot	Used to sew without dual feed.	
	1D	Reverse pattern foot	Used to sew with dual feed.	
	3A	Automatic Buttonhole foot with slide	Used to sew buttonholes.	
	4D	Zipper foot	Used with dual feed. For sewing in zippers.	
	20C	Open embroidery foot	Appliqués, decorative patterns.	
	42	BSR foot	Free-motion quilting with regular stitch length.	

Illustration	Number	Name	Purpose	Example
	97D	Patchwork foot	The patchwork foot is ideal for patchworking and other precise sewing tasks.	

### Accessory box

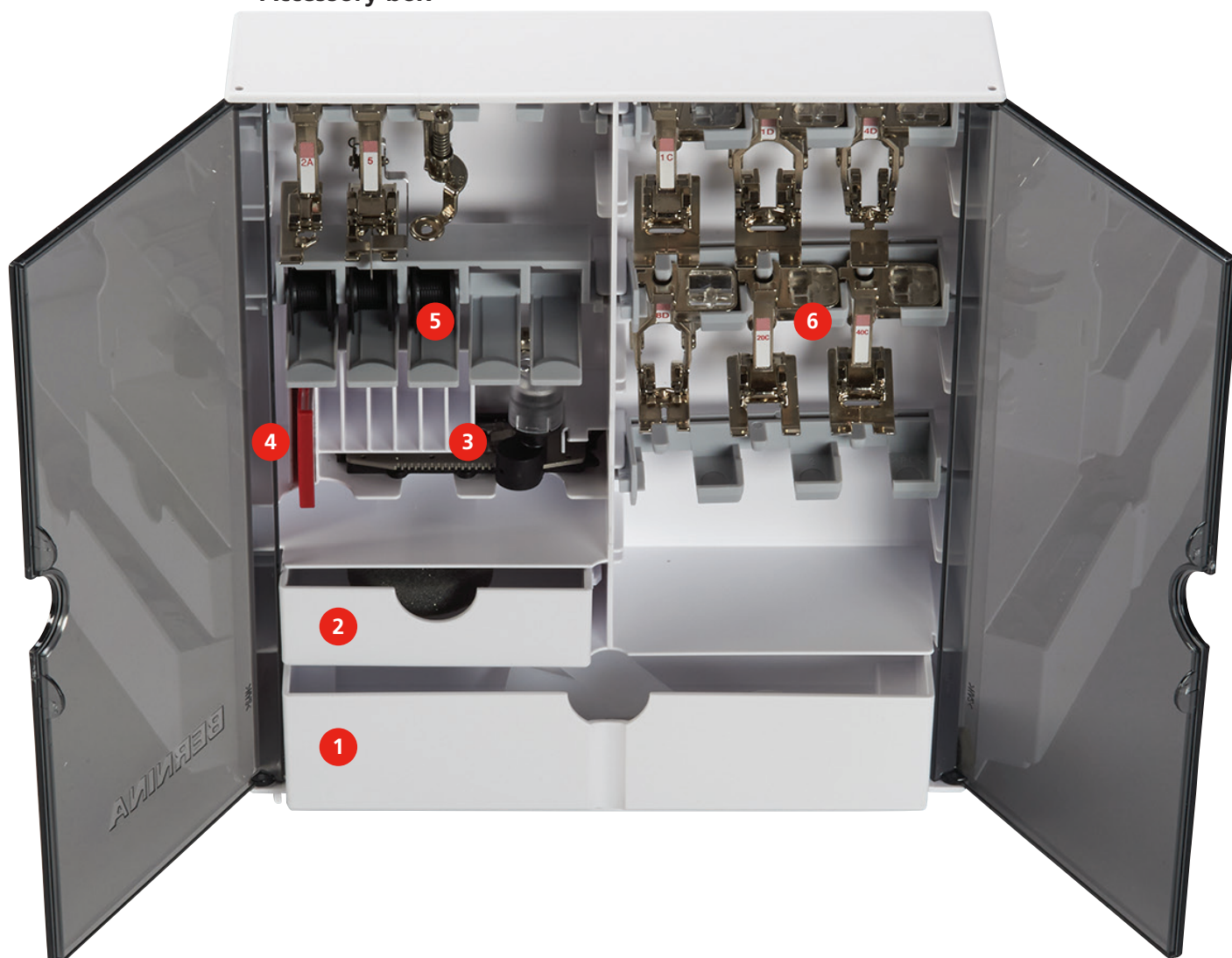

- |   |                                      |   |                      |
|---|--------------------------------------|---|----------------------|
| 1 | Big drawer                           | 4 | Selection of needles |
| 2 | Small drawer                         | 5 | Bobbins              |
| 3 | Automatic Buttonhole foot with slide | 6 | Presser feet         |

## 1.6 Overview Selection Menu on the left (External Functions/Views)



- |   |                       |   |                                |
|---|-----------------------|---|--------------------------------|
| 1 | Upper thread tension  | 4 | Stitch plate/Needle selection  |
| 2 | Presser foot display  | 5 | Feed dog up/down               |
| 3 | Presser foot pressure | 6 | Filling level of bobbin thread |

## 1.7 Overview Selection Menu below (System settings)

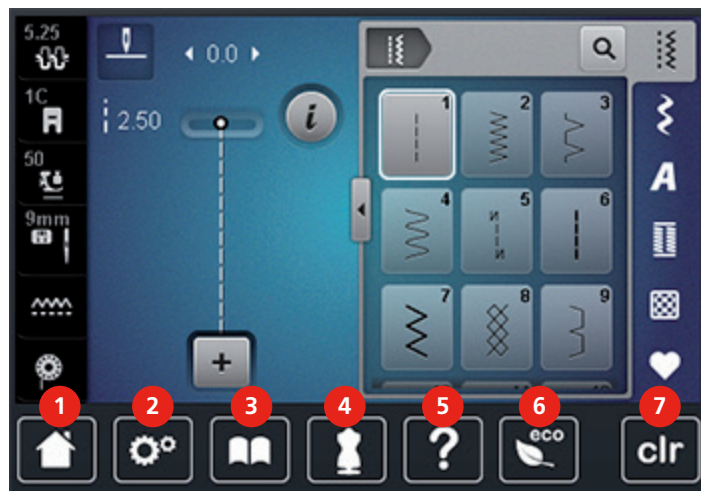









- |   |                     |   |                       |
|---|---------------------|---|-----------------------|
| 1 | Home                | 5 | Help                  |
| 2 | Setup Program       | 6 | eco mode              |
| 3 | Tutorial            | 7 | Back to basic setting |
| 4 | Creative Consultant |   |                       |

## 1.8 Buttons and icons

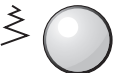
Icon	Name	Purpose
	Close	The screen is closed and the previously made adjustments are saved.



Icon	Name	Purpose
	Confirm	Confirms any adjusted settings. The screen is closed.
	Cancel	The process is canceled. The screen is closed and the previously made adjustments are not saved.
 	Touch the icons «-/+»	Via the icons «-» and «+» setting values can be changed.
 	«Upper Multifunctional knob» and «Lower Multifunctional knob»	Via the «Upper Multifunctional knob» and the «Lower Multifunctional knob» setting values can be changed.
	Slide	By moving the slide the setting values are changed.
	Switch	Activates or deactivates functions.
	Process navigation	With the process navigation scrolling back in the display is possible.
	Wiping function	By wiping up or down on the display with the touchscreen pen or the finger further functions can be displayed.

## 1.9 Needle, Thread, Fabric

In the course of time a needle wears out. Therefore it should be replaced regularly. Only a perfect point results in a good stitching result. In general it can be said: the thinner the thread, the finer the needle. The illustrated needles are either standard or optional accessory, depending on the machine.

- Sizes 70, 75: for thin fabrics.
- Sizes 80, 90: for medium fabrics.
- Sizes 100, 110 and 120: for heavy fabrics.













Illustration	Needle name	Needle description	Purpose
	<b>Universal</b> 130/705 H/60-100	Average point, slightly rounded	For nearly all natural and synthetic fabrics (woven and knitted).

Illustration	Needle name	Needle description	Purpose
	<b>Jersey/Stretch</b>  130/705 H-S, H-SES, H-SUK/70-90	Ball point	Jersey, tricot, knit and stretch fabrics.
	<b>Leather</b>  130/705 H-LL, H-LR/90-100	With cutting point	All types of leather, synthetic leather, plastic, sheeting.
	<b>Jeans</b>  130/705 H-J/80-110	Very fine point	Heavy weight fabrics such as jeans, canvas.
	<b>Microtex</b>  130/705 H-M/60-90	Especially fine point	Micro fiber fabrics and silk.
	<b>Quilting</b>  130/705 H-Q/75-90	Fine point	Straight and topstitching.
	<b>Embroidery</b>  130/705 H-SUK/70-90	Large eye, slight ball point	Embroidery on all natural and synthetic fabrics.
	<b>Metafil</b>  130/705 H-MET/75-80 or H-SUK/90-100	Large eye	Sewing projects with metallic threads.
	<b>Cordonnet (Topstitching)</b>  130/705 H-N/80-100	Small ball point, long eye	Topstitching with thick thread.
	<b>Wing needle (Hemstitch needle)</b>  130/705 HO/100-120	Wide needle (wing)	Hemstitching.
	<b>Double wing needle</b>  130/705 H-ZWI-HO/100		For special effects with hemstitch embroidery.
	<b>Double needle</b>  130/705 H-ZWI/70-100	Needle distance: 1.0/1.6/2.0/2.5/ 3.0/4.0/6.0/8.0	Visible hems in stretch fabrics: pintucks, decorative sewing.
	<b>Triple needle</b>  130/705 H-DRI/80	Needle distance: 3.0	Visible hems in stretch fabrics, pintucks, decorative sewing.

## Thread selection

For a perfect sewing result, thread and fabric quality play an important role.

We recommend purchasing quality threads to achieve good sewing results.

- Cotton threads have the advantage of being a natural fiber and therefore are especially suitable for sewing cotton fabrics.
- Mercerized cotton threads have a slight sheen that is not lost with washing.
- Polyester threads have a high tensile strength and is particularly colorfast.
- Polyester threads are more flexible and are recommended where a strong and elastic seam is required.
- Rayon threads are made of natural fibers and have a brilliant sheen.
- Rayon threads are suitable for decorative stitches and achieve a more beautiful effect.

## Example for needle description

The 130/705 system, which is the most common for household machines, is explained by the following picture of a Jersey/Stretch needle.

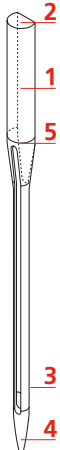
	<p><b>130/705 H-S/70</b></p> <p><b>130</b> = Shank length (1)</p> <p><b>705</b> = Flat shank (2)</p> <p><b>H</b> = Needle scarf (3)</p> <p><b>S</b> = Needle point (here medium ball point) (4)</p> <p><b>70</b> = Needle size (shank diameter) (5)</p>
--	---

## Needle/thread combination

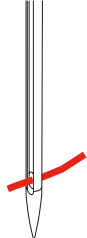
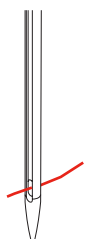
	<p>The needle/thread combination is correct, when the thread fits perfectly into the long groove and goes easily through the needle eye. The thread can be optimally sewn.</p>
	<p>The thread can break and skipped stitches can occur when there is too much clearance in the long groove and the needle eye.</p>



## 2 Sewing preparation

### 2.1 Accessory box

#### Accessory box free standing

- > On the back of the box, pull both extensions out until they click into place.



#### Storing accessories

##### NOTICE Incorrect sorting of the bobbin

The silvery sensor surface can get scratched.

- > Make sure that the silvery sensor surfaces are on the right side when sorting the bobbins into the accessory box.

- > Store small parts in the drawers (1) and (2).
- > Store the Buttonhole foot with slide No. 3A in compartment (3).
- > Store the provided needle package in the special compartment (4).
- > Insert the bobbins into the compartment (5) of the accessory box so that the silvery sensor surfaces are on the right side.
- > To remove a bobbin, press the compartment holder down.
- > Store the presser feet in the compartment (6).

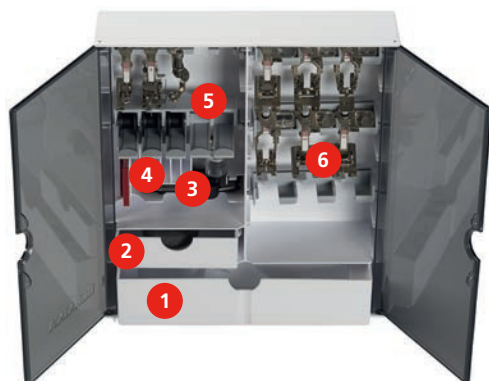



## 2.2 Connection and Switching on

### Connecting the foot control

- > Unwind the cable of the foot control to the desired length.



- > Insert the cable of the foot control into the connection (1).



### Connecting the machine

- > Insert the power cable into the connection (1).



- > Insert the plug of the power cable into the electrical outlet.

## Attaching the lever of the Free Hand System



The lateral position of the lever can be adjusted by your local BERNINA Dealer required.

- > Insert the FHS lever into the opening at the front side of the machine.

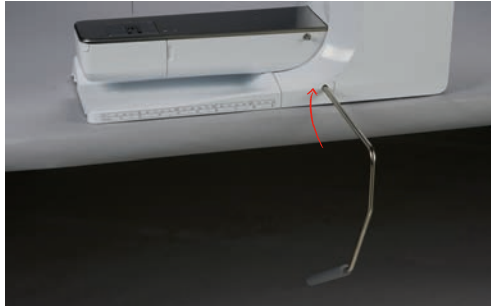

## Fixing the touchscreen pen

- > Store the touchscreen pen at the magnet holder (1).



## Switching the machine on

- > Switch the main power switch to (1) «I».



## 2.3 Foot control

### Sewing speed control

With the foot control the sewing speed can be adjusted steplessly.

- > Press the foot control down carefully to start the machine.
- > To sew faster, press the foot control harder.



- > Release the foot control to stop the machine.



### Raising/Lowering the needle

- > Sink the heel back on the foot control to raise/lower the needle.



## 2.4 Spool holder

### Installing the spool holder



With metallic or other special threads, it is recommend to use the swiveling spool holder and the eyelet for metallic and silk thread (optional accessory).

The swiveling spool holder is necessary when several threads are sewn and it can also be used for bobbin winding while sewing.

- > Swivel the spool holder up as far as it will go.



### Inserting foam pads

The foam pad prevents the thread from getting hooked at the swiveling spool holder.

- > Place the foam pad on the swiveling spool holder.



### Positioning the spool disc

Spool discs hold the thread spool in place for proper release of thread from the spool.

- > Place the foam pad on the spool holder.
- > Place the thread spool on the spool pin.
- > Position the appropriate spool disc on the spool pin so that there is no space between the spool disc and the thread spool.



### Using a spool net

The spool net provides an even unwinding of the thread from the thread spool and prevents the thread from knotting and breaking.

- > Place the thread spool on the spool holder.
- > Pull the spool net over the thread spool.

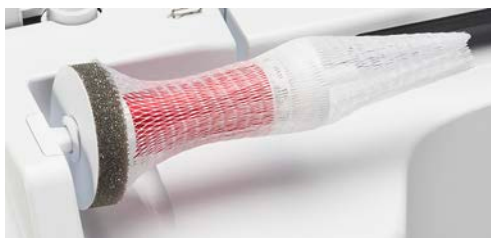

## 2.5 Free arm

### Adjusting the feed dog



#### NOTICE Inappropriate handling of the fabric

Damage of the needle and the stitch plate.

- > Let the sewing project be fed evenly.

With each stitch, the feed dog moves forward by one step. The length of this step is determined by the stitch length selected.

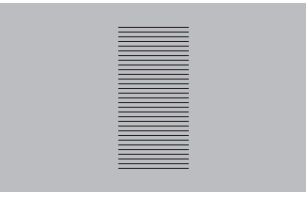
With a short stitch length, the steps are very short. For example when sewing buttonholes and satin stitches. The fabric is fed slowly under the presser foot, even when sewing at maximal speed.

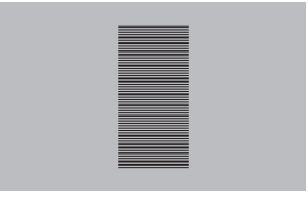
	<p>Let the fabric be fed evenly; this results in a more perfect stitch formation.</p>
	<p>Pulling or pushing the fabric will result in uneven stitches.</p>
	<p>Holding back the fabric will result in uneven stitches.</p>

- > Push the button «Feed dog up/down» (1) to lower the feed dog.



- > Push the button again to sew with the feed dog up.

### Using the slide-on table

- > Raise the needle.
- > Raise the presser foot.
- > Switch the machine off and disconnect it from the power supply system.

- > Push the slide-on table to the right until it engages.



- > To remove the slide-on table, push the button down and pull the slide-on table to the left.



## 2.6 Presser foot

### Adjusting the presser position via the lever of the Free Hand System

- > Adjust the sitting height so that the lever can be operated with the knee.
- > Move the lever with the knee to the right to raise the presser foot.

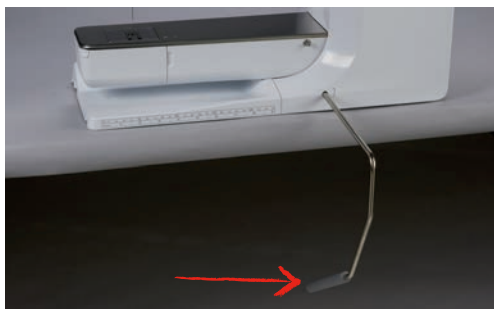

- Simultaneously the feed dog is lowered and the thread tension is released.
- > Release the lever slowly to lower the presser foot.

### Adjusting the presser foot position via the button Presser foot up/down



- > Press the button «Presser foot up/down» to raise the presser foot.
- > Press the button «Presser foot up/down» again to lower the presser foot.

### Changing the presser foot

- > Raise the needle.
- > Raise the presser foot.
- > Switch the machine off and disconnect it from the power supply system.

- > Push the clamping lever up.



- > Remove the presser foot.
- > Guide the new presser foot upwards over the cone.
- > Press the clamping lever down.

### Displaying the presser foot

After the presser foot has been changed, it can be checked whether or not the presser foot is suitable for the selected stitch pattern. In addition to that, alternative presser feet are displayed which are available for the currently selected stitch pattern.

- > Switch the machine on.
- > Select a stitch pattern.
- > Touch the icon «Presser foot display».
- > Using the touchscreen pen or the finger, wipe up in the area of the presser feet to display alternative presser feet.

A



- When the attached presser foot is suitable, sewing can be started.

### Adjusting the presser foot pressure



With thick fabrics it is recommended to reduce the presser foot pressure. The advantage is that the presser foot is slightly lifted so that the fabric can be moved more easily.

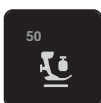

- > Touch the icon «Presser foot pressure».
- > Move the slide with the touchscreen pen or the finger to adjust the presser foot pressure.
- > Touch the yellow-framed icon to reset the alterations to basic setting.



## 2.7 Adjusting the feed dog



- > Touch the icon «Feed dog up/down» to raise or lower the feed dog according to the animation.

## 2.8 Checking the filling level of the bobbin thread

The remaining bobbin thread is indicated on the display.



- > Touch the icon «Filling level of bobbin thread».
- > Thread the bobbin thread according to the animation.

## 2.9 Needle and stitch plate

### Adjusting the needle position up/down



- > Press the button «Needle up/down» to lower the needle.
- > Press the button «Needle up/down» again to raise the needle.

### Adjusting the needle position left/right

There is a total of 11 needle positions. The needle position is indicated by the needle position number in the display.

- > Press the button «Needle left» (1) to move the needle to the left.
- > Press the button «Needle right» (2) to move the needle to the right.

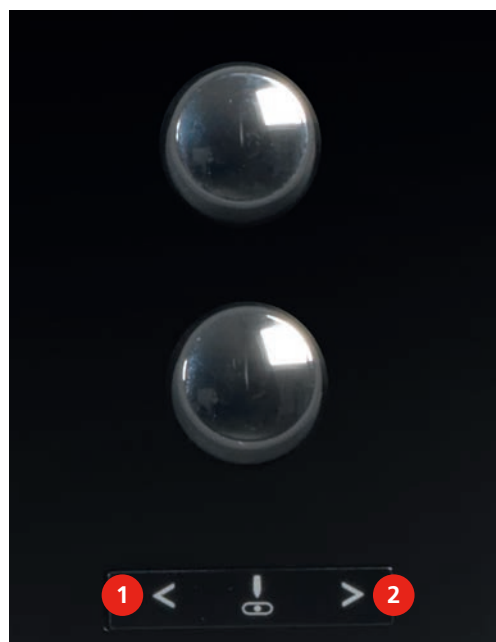

### Needle stop up/down (permanent)



- > Touch the icon «Needle stop up/down (permanent)» to fix the needle position permanently.
  - The machine stops with needle position down as soon as the foot control is released or the button «Start/Stop» has been pressed.
- > Touch the icon «Needle stop up/down (permanent)» again.
  - The machine stops with needle position up as soon as the foot control is released or the button «Start/Stop» has been pressed.

## Changing the needle

- > Raise the needle.
- > Switch the machine off and disconnect it from the power supply system.
- > Remove the presser foot.
- > Loosen the needle clamp screw using the screwdriver grey Torx.



- > Pull the needle down.
- > Hold the new needle with the flat side to the back.
- > Insert the needle as far as it will go.
- > Tighten the needle clamp using the screwdriver grey Torx.

## Selecting the needle

After having changed the needle, it can be checked whether or not it can be used in combination with the selected stitch plate.

- > Touch the icon «Stitch plate/Needle selection».



- > Selected the inserted needle.

## Select the needle type and the needle size

Convenient memory function: To prevent a loss of information, the needle type and the needle size can be saved additionally on the machine. The saved needle type and the saved needle size can be checked at any time.

- > Touch the icon «Stitch plate/Needle selection».





- > Touch the icon «Needle type/Needle size».
- > Select the needle type (1) of the inserted needle.
- > Select the needle size (2) of the inserted needle.



### Changing the stitch plate

The stitch plate is marked with vertical, horizontal and diagonal lines in millimeters (mm) and inches (inch). These lines help to guide the fabric when sewing seams and precise topstitching.

- > Lower the feed dog.
- > Switch the machine off and disconnect it from the power supply system.
- > Remove the needle.
- > Remove the presser foot.
- > Press the stitch plate down at the mark back right until it flips up.



- > Remove the stitch plate.
- > Place the openings of the new stitch plate above the corresponding guide pins and press down until it clicks into place.

### Selecting the stitch plate

After having changed the stitch plate, it can be checked whether or not it can be used in combination with the selected needle.



- > Touch the icon «Stitch plate/Needle selection».

- > Select the previously attached stitch plate.



- When the selected stitch plate is suitable in combination with the needle, sewing can be started.
- When the selected stitch plate is not suitable in combination with the needle, the machine prevents starting automatically.

## 2.10 Threading

### Threading preparation

- > Raise the needle.
- > Raise the presser foot.
- > Switch the machine off and disconnect it from the power supply system.

### Threading the upper thread

- > Place the foam pad on the spool holder.
- > Place the thread spool on the pin so that the thread is unwound clockwise.
- > Add the appropriate thread disc.
- > Guide the thread in direction of the arrow into the rear thread guide and hold the thread with the hands so that it is taut and can be inserted into the thread pretension.
- > Guide the thread in direction of the arrow through the tread pretension.



- > Pull the thread in direction of the arrow down (1) around the cover of the thread take-up lever (2).
- > Guide the thread in direction of the arrow up (3) and insert it into the thread take-up lever.

> Pull the thread in direction of the arrow down (4).



> Guide the thread through the guides above the presser foot.



> Switch the machine on.



- > Press the lever down, keep pressed and pull the thread to the left.



- > Guide the thread around the grey hook from the left to the right.
- > Pull the thread through the thread guide until it engages in the wire hook.

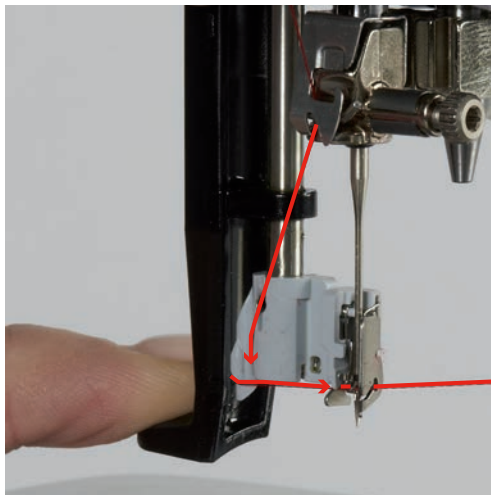

- > Release the lever and the thread simultaneously to thread the needle.
- > Pull the thread loop to the back.

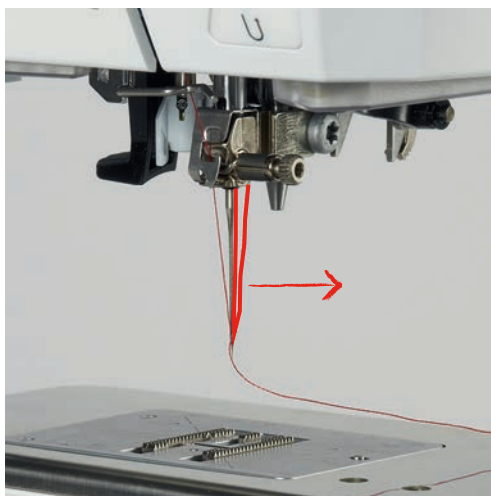

- > Pull the thread under the presser foot and pull it over the thread cutter from back to front to cut.



### Threading the double needle

Prerequisite:

- The double needle is inserted.
- > Guide the first thread in direction of the arrow on the right side of the tension disc (1).
- > Guide the second thread in direction of the arrow on the left side of the tension disc (1).



- > Guide the first and the second thread to the thread guide above the needle (see page 41).
- > Thread the first thread manually into the right needle.
- > Thread the second thread manually into the left needle.

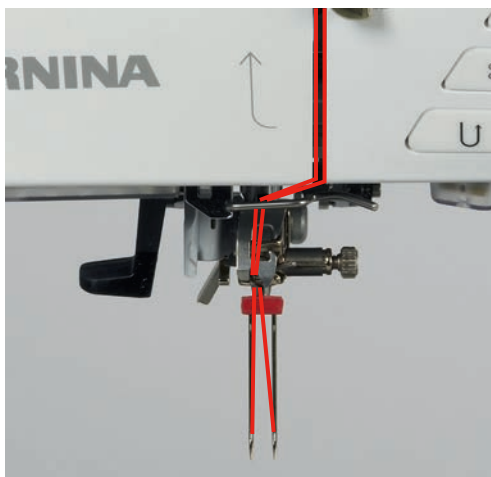



## Threading the triple needle

Always attach a foam pad when using the swiveling spool holder. This prevents the thread from getting hooked at the spool holder.

Prerequisite:

- The triple needle is inserted.
- > Place the foam pad, the thread spool and the appropriate thread disc on the spool holder.
- > Place the filled bobbin on the swiveling spool holder.
- > Add the appropriate thread disc.
- > Place the thread spool.
- > Thread the 3 threads up to the upper thread guide.

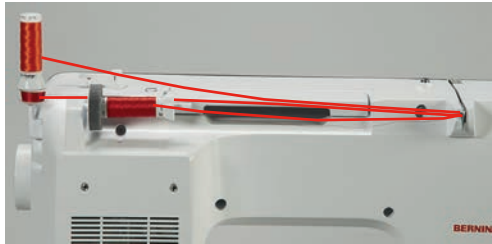

- > Guide 2 threads past the thread tension discs on the left and to the thread guide above the needle (see page 41).
- > Guide 1 thread past the thread tension disc on the right and to the thread guide above the needle (see page 41).
- > Thread the first thread into the left needle manually.
- > Thread the second thread into the center needle manually.
- > Thread the third thread into the right needle manually (see page 44).

## Winding the bobbin thread



The bobbin thread can be wound while sewing if the swiveling spool holder is used for winding.

- > Place a foam pad on the spool holder.
- > Place the thread spool on the spool holder.
- > Add the appropriate thread disc on the spool holder.
- > Attach the empty bobbin on the winding unit (1) so that the silvery sensor surface is down.



- > Guide the thread in direction of the arrow into the rear thread guide (1).
- > Guide the thread around the thread pretension clockwise (2).

- > Wind the thread clockwise two to three times around the empty bobbin (3).

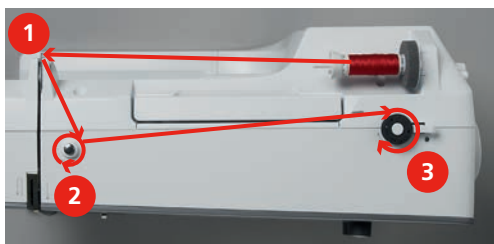

- > Pull the excess thread over the thread cutter at the engaging lever and cut.



- > Push the engaging lever towards the bobbin.



- The machine winds and the display to wind the bobbin appears.
- > Move the slide on the display using the touchscreen pen or the finger to adjust the winding speed.
- > Push the engaging lever to the right to stop the winding process.
- > Push the engaging lever towards the bobbin again to continue the winding process.
  - As soon as the bobbin is full, the machine stops the winding process automatically.
- > Remove the bobbin and cut the thread using the thread cutter at the engaging lever.

### Threading the bobbin thread

- > Raise the needle.
- > Switch the machine off.
- > Open the bobbin cover.



- > Pull the thread to the right under the spring (1), then lead the thread under the thread guide and pull upwards.



- > Hold the bobbin case so that the thread guide points upward.

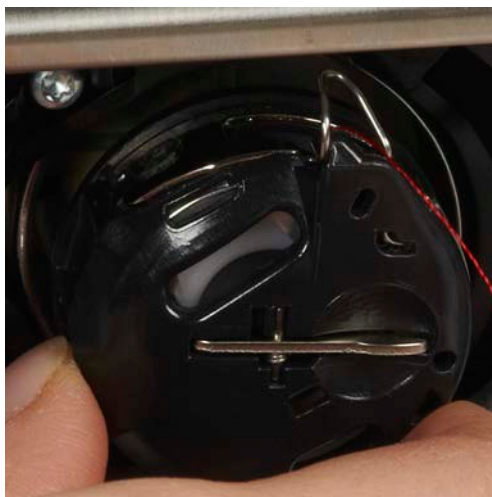

- > Insert the bobbin case.
- > Press onto the center of the bobbin case until it engages.
- > Pull the thread through the thread cutter and cut.

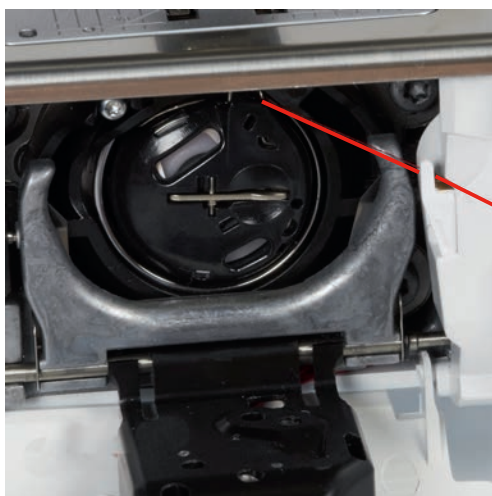

- > Close the bobbin cover.



## 2.11 Calling up the Tutorial

The tutorial provides information and explanations on different sections concerning sewing and embroidering and the various stitches.



- > Touch the icon «Tutorial».
- > Select the desired topic to get information.

## 2.12 Calling up the Help



- > Touch the window in the display where help is needed.
- > Touch the icon «Hilfe» to start the help mode.
- > Touch the icon in the display where help is needed.
  - Assistance concerning the selected icon is displayed.

## 2.13 Calling up the Creative Consultant

The Creative Consultant provides information about decision support concerning sewing projects. After entering the fabric and the desired sewing project, suggestions for suitable needles, presser feet etc. are displayed.



- > Touch the icon «Creative Consultant».
- > Select the fabric to be sewn.
- > Select the sewing project.

## 3 Setup-Program

### 3.1 Sewing settings

#### Adjusting the upper thread tension

Alterations of the upper thread tension in the Setup Program affect all stitch patterns. Individual alteration of the upper thread tension can also be made for currently selected stitches.



- > Touch the icon «Setup Program».



- > Touch the icon «Sewing settings».



- > Touch the icon «Adjusting the upper thread tension».
- > Move the slide using the touchscreen pen or the finger to adjust the upper thread tension.
- > Touch the yellow-framed icon to reset the alteration to basic setting.

#### Adjusting the maximum sewing speed



- > Touch the icon «Setup Program».



- > Touch the icon «Sewing settings».



- > Touch the icon «Adjusting maximum sewing speed».
- > Move the slide using the touchscreen pen or the finger to adjust the maximum sewing speed.
- > Touch the yellow-framed icon to reset the alteration to basic setting.

#### Programming the securing stitches

If the function is activated, 4 securing stitches are sewn automatically at the pattern start after the thread cut.



- > Touch the icon «Setup Program».



- > Touch the icon «Sewing settings».



- > Touch the switch using the touchscreen pen or the finger to deactivate the securing stitches.
- > Touch the switch again to activate the securing stitches.

#### Adjusting the hovering height of the presser foot



- > Touch the icon «Setup Program».



> Touch the icon «Sewing settings».



> Touch the icon «Programming buttons and icons».



> Touch the icon «Programming hovering height of the presser foot».

> Turn the «Upper Multifunctional knob» or the «Lower Multifunctional knob» or touch the icons «-» and «+» to determine the distance between the fabric and the presser foot.

> Touch the yellow-framed icon to reset the alteration to basic setting.

### Programming the button «Pattern end»



> Touch the icon «Setup Program».



> Touch the icon «Sewing settings».



> Touch the icon «Programming buttons and icons».



> Touch the icon «Programming the button Pattern end».



> Touch the icon «Securing» to sew 4 securing stitches in place.

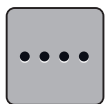

> Touch the icon «Altering the number of securing stitches» to program sequenced securing stitches.

> Touch the icons «-» and «+» to program the number of the sequenced securing stitches.

> Touch the yellow-framed icon to reset the alteration to basic setting.

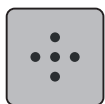

> Touch the icon «Securing stitches in place» to program 4 securing stitches in place.



> Touch the icon «Thread cut» to deactivate the automatic thread cut after securing.

> Touch the icon «Thread cut» again to activate the automatic thread cut after securing.



> Touch the icon «Positioning the presser foot» to raise the presser foot after securing.

> Touch the icon «Positioning the presser foot» again to raise the presser foot after securing.



> Touch the icon «Securing» to deactivate the automatic securing.

> Touch the icon «Securing» again to activate the automatic securing.

### Programming the button «Thread cutter»



> Touch the icon «Setup Program».





> Touch the icon «Sewing settings».



> Touch the icon «Programming buttons and icons».



> Touch the icon «Programming the button Thread cutter».



> Touch the icon «Securing» to sew 4 securing stitches in place.

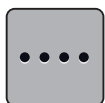

> Touch the icon «Changing the number of securing stitches» to enter the number of the sequenced securing stitches.

> Touch the icons «-» and «+» to enter the number of the sequenced securing stitches.

> Touch the yellow-framed icon to reset the alteration to basic setting.

> Touch the icon «Securing stitches in place» to program 4 securing stitches in place.

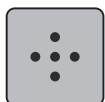

> Touch the icon «Securing» to deactivate the automatic securing.

> Touch the icon «Securing» again to activate the automatic securing.

### Adjusting the presser foot position with needle stop down

With lowered needle, 3 different presser foot position can be selected: the presser foot lowered, the presser foot is raised to hovering position and the presser foot is raised to its maximum height.



> Touch the icon «Setup Program».



> Touch the icon «Sewing settings».



> Touch the icon «Programming buttons and icons».



> Touch the icon «Adjusting the presser foot position with needle stop down».



> Select the desired presser foot position.

### Programming the button «Quick reverse»



> Touch the icon «Setup Program».



> Touch the icon «Sewing settings».



> Touch the icon «Programming buttons and icons».



> Touch the icon «Programming the button Quick reverse».



> Touch the icon «Backstepping» to activate the backstepping.

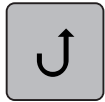

> Touch the icon «Quick reverse permanent» to activate the permanent reverse sewing.

### Programming the foot control



> Touch the icon «Setup Program».



> Touch the icon «Sewing settings».



> Touch the icon «Programming the foot control».

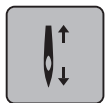

- The icon «Needle up/down» is activated.
- The back kick on the foot control raises or lowers the needle.



> Touch the icon «Back kick» to program the back kick.



> Touch the icon «Securing» to sew 4 securing stitches in place.



- > Touch the icon «Altering the number of securing stitches» to program sequenced securing stitches.
- > Touch the icons «-» and «+» to program the number of securing stitches.
- > Touch the yellow-framed icon to reset the alteration to basic setting.



> Touch the icon «Securing stitches in place» to program 4 securing stitches in place.



- > Touch the icon «Securing» to deactivate the automatic securing via the back kick.
- > Touch the icon «Securing» again to activate the automatic securing via the back kick.



- > Touch the icon «Cutting the thread» to deactivate the automatic thread cut.
- > Touch the icon «Cutting the thread» again to activate the automatic thread cut.



- > Touch the icon «Positioning the presser foot» so that the presser foot remains down via the back kick.
- > Touch the icon «Positioning the presser foot» again so that the presser foot remains up via the back kick.

## 3.2 Embroidery settings

### Adjusting the upper thread tension

Alterations of the upper thread tension in the Setup Program affect all stitch patterns. Individual alteration of the upper thread tension can also be made for currently selected stitches.



> Touch the icon «Setup Program».



> Touch the icon «Embroidery settings».



- > Touch the icon «Adjusting the upper thread tension».
- > Move the slide using the touchscreen pen or the finger to alter the upper thread tension.
- > Touch the yellow-framed icon to reset the alteration to basic setting.

### Adjusting the maximum embroidering speed



> Touch the icon «Setup Program».



> Touch the icon «Embroidery settings».



- > Touch the icon «Adjusting the maximum embroidering speed».
- > Move the slide using the touchscreen pen or the finger to adjust the maximum embroidering speed.
- > Touch the yellow-framed icon to reset the alteration to basic setting.

### Calibrating the hoop

Prerequisite:

- The embroidery module is connected and the embroidery hoop with the appropriate embroidery template is attached.



> Touch the icon «Setup Program».



> Touch the icon «Embroidery settings».



- > Touch the icon «Calibrating the embroidery hoop».
- > Select the desired embroidery hoop and follow the instructions in the display.

- > Center the needle via the arrow icons on the display.



### Entering the fabric thickness

When the machine is switched off, the alterations are reset to the basic setting 4 mm. If the fabric thickness is more than 4 mm as for e.g. toweling, it is recommended to select 7.5 mm or 10 mm.



- > Touch the icon «Setup Program».



- > Touch the icon «Embroidery settings».



- > Touch the icon «Selecting the fabric thickness».
- > Select fabric thickness.

### Deactivating securing stitches



- > Touch the icon «Setup Program».



- > Touch the icon «Embroidery settings».



- > Touch the icon «Securing stitches on/off».
- > Touch the switch in the upper right portion of the display to deactivate the securing stitches.
  - No securing stitches will be sewn and the bobbin thread needs to be brought up manually and held when embroidering is started.
- > Touch the switch again to activate the securing stitches.

### Deactivating the thread catcher



- > Touch the icon «Setup Program».



> Touch the icon «Embroidery settings».



- > Touch the icon «Securing stitches on/off».
- > Touch the switch in the lower right portion to deactivate the thread catcher.
- > Touch the switch again to activate the thread catcher.

### Programming the automatic thread cut



> Touch the icon «Setup Program».



> Touch the icon «Embroidery settings».



> Touch the icon «Thread cut settings».



- > Touch the switch in the upper portion of the display (1) to deactivate the automatic thread cut after a color change.
- > Touch the switch in the upper portion of the display (1) again to activate the automatic thread cut after a color change.
- > Touch the switch in the lower portion of the display (2) to deactivate the automatic thread cut after starting embroidering.
- > Touch the switch in the lower portion of the display (2) again to activate the automatic thread cut after starting embroidering.

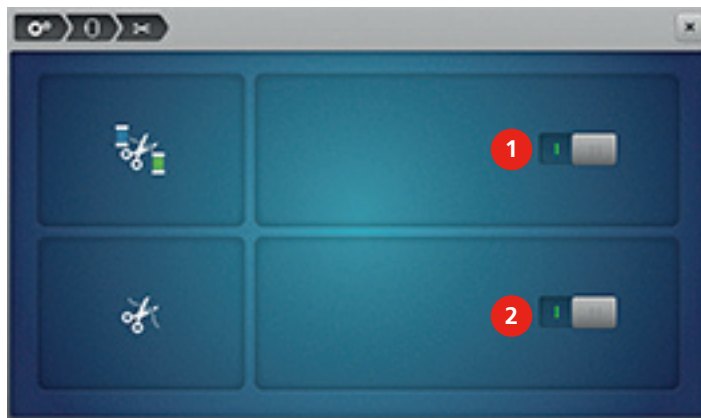

### 3.3 Selecting personal settings



> Touch the icon «Setup Program».



- > Touch the icon «Personal settings».
- > Select the desired color of the display and the background.





### 3.5 Activating the audio signals



> Touch the icon «Setup Program».



> Touch the icon «Audio signals».

> Touch the switch (1) to deactivate any audio signals in general.

> Touch the switch (1) again to activate any audio signals in general.

> In the section (2) touch the icons «1 – 4» to set up the desired signal for the selection of a stitch pattern.



> In the section (2) touch the icon «Loudspeaker» to deactivate the signal for the selection of a stitch pattern.

> In the section (2) touch the icon «Loudspeaker» again to activate the signal for the selection of a stitch pattern.



> In the section (3) touch the icons «1 – 4» to activate the signal for the selection of functions.

> In the section (3) touch the icon «Loudspeaker» to deactivate the signal for the selection of functions.

> In the section (3) touch the icon «Loudspeaker» again to activate the signal for the selection of functions.



> In the section (4) touch the icon «Loudspeaker» to deactivate the signal when using the BSR modes.

> In the section (4) touch the icon «Loudspeaker» again to activate the signal when using the BSR modes.



### 3.6 Machine settings

#### Selecting a language



> Touch the icon «Setup Program».



> Touch the icon «Machine settings».



> Touch the icon «Language selection».

> Select a language.

#### Adjusting the brightness of the display



> Touch the icon «Setup Program».





> Touch the icon «Machine settings».



- > Touch the icon «Display settings».
- > Move the slide in the upper portion of the display using the touchscreen pen or the finger to alter the brightness of the display.
- > Touch the yellow-framed icon to reset the alteration to basic setting.

### Adjusting the sewing light



> Touch the icon «Setup Program».



> Touch the icon «Machine settings».



- > Touch the icon «Display settings».
- > Move the slide in the lower portion of the display using the touchscreen pen or the finger to alter the brightness of the sewing light.
- > Touch the yellow-framed icon to reset the alteration to basic setting.



- > Touch the switch to switch the sewing light off.
- > Touch the switch again to switch the sewing light on.

### Calibrating the display



> Touch the icon «Setup Program».



> Touch the icon «Machine settings».





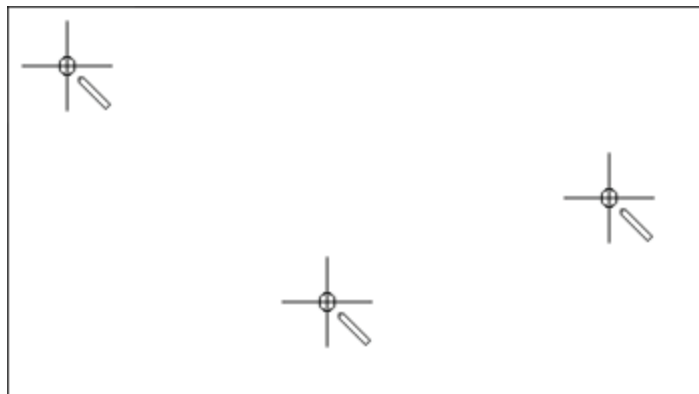





- > Touch the icon «Calibrating the display».
- > Touch the crosses in sequence using the touchscreen pen.









### Back to basic setting



> Touch the icon «Setup Program».

-  > Touch the icon «Machine settings».
-  > Touch the icon «Basic setting».
-  > Touch the icon «Basic setting Sewing».
-  > Touch the icon «Confirm» to restore basic settings for the sewing settings.
-  > Touch the icon «Basic setting Embroidering».
-  > Touch the icon «Confirm» to restore basic settings for the embroidery settings.
-  > Touch the icon «Basic setting all».
-  > Touch the icon «Confirm» to restore all the basic settings.

### Deleting user data





-  > Touch the icon «Setup Program».
-  > Touch the icon «Machine settings».
-  > Touch the icon «Basic settings».
-  > Touch the icon «Deleting data from personal memory».
-  > Touch the icon «Confirm» to delete all data from the personal memory.
-  > Touch the icon «Deleting personal embroidery motifs».
-  > Touch the icon «Confirm» to delete all embroidery motifs from the personal memory.

### Deleting data from the BERNINA USB Stick (optional accessory)

If saved data on the BERNINA USB Stick (optional accessory) is not needed anymore, the stick can be connected to the machine and the data can be deleted.

- > Insert the BERNINA USB Stick (optional accessory) into the port (1).







-  > Touch the icon «Setup Program».
-  > Touch the icon «Machine settings».
-  > Touch the icon «Basic settings».
-  > Touch the icon «Deleting data from USB Stick».
-  > Touch the icon «Confirm» to delete all data on the BERNINA USB Stick (optional accessory).

### Calibrating the Buttonhole foot No. 3A

The Buttonhole foot No. 3A is calibrated to this machine and should only be used both together.

Prerequisite:

- The Buttonhole foot No. 3A is attached.
- The needle is not threaded.

-  > Touch the icon «Setup Program».
-  > Touch the icon «Machine settings».
-  > Touch the icon «Maintenance/Update».
-  > Touch the icon «Buttonhole foot No. 3A».
-  > Touch the button «Start/Stop» to start the calibration.

### Updating the software

**NOTICE** BERNINA USB stick (optional accessory) has been removed too early

The software has not been updated and the machine cannot be used.

- > Remove the BERNINA USB stick (optional accessory) only after the update has been completed successfully.

The latest software and a detailed step by step instruction can be downloaded at [www.bernina.com](http://www.bernina.com). In general, personal data and settings are automatically transferred during a software update. For reasons of safety, it is recommended to save data and settings on a BERNINA USB stick (optional accessory) before the software update is started. If personal data and settings should get lost during an update, they can be transferred to the machine again afterwards.

- > Insert the BERNINA USB Stick (optional accessory), FAT32 formatted, providing the latest software into the port(1).



- > Touch the icon «Setup Program».



- > Touch the icon «Machine settings».



- > Touch the icon «Maintenance/Update».



- > Touch the icon «Updating the machine».



- > Touch the icon «Saving data on USB stick».



- > Touch the icon «Update» to start the update of the software.

## Recovering saved data

NOTICE BERNINA USB stick (optional accessory) has been removed too early





Saved data cannot be transferred and the machine cannot be used.

- > Remove the BERNINA USB stick (optional accessory) only after the saved data has been transferred successfully.

If personal data and settings after a software update are not available anymore, they can be transferred to the machine again afterwards.





- > Insert the BERNINA USB stick (optional accessory) with the latest software into the USB port (1).



-  > Touch the icon «Setup Program».
-  > Touch the icon «Machine settings».
-  > Touch the icon «Maintenance/Update».
-  > Touch the icon «Updating the machine».
-  > Touch the icon «Transferring saved data to machine».





### Cleaning the machine

The Setup Program provides animations how to clean the machine. In chapter «Maintenance and Cleaning», there are more illustrated step by step instructions (see page 152).

-  > Touch the icon «Setup Program».
-  > Touch the icon «Machine settings».
-  > Touch the icon «Maintenance/Update».
-  > Touch the icon «Cleaning the machine».
- > Clean the machine according to the instructions on the display.

### Lubricating the machine

The Setup Program provides animations how to oil the machine. In chapter «Maintenance and Cleaning»; there are more illustrated step by step instructions (see page 152). Use BERNINA oil to lubricate.

-  > Touch the icon «Setup Program».
-  > Touch the icon «Machine settings».
-  > Touch the icon «Maintenance/Update».
-  > Touch the icon «Lubricating the machine».
- > Lubricate the machine according to the instructions on the display.

## Packing the embroidery module

To pack the embroidery module into the original packaging without moving the embroidery arm manually, the embroidery arm needs to be brought to its packing position.

Prerequisite:

- The embroidery module is connected with the machine.



> Touch the icon «Setup Program».



> Touch the icon «Machine settings».



> Touch the icon «Maintenance/Update».



> Touch the icon «Packing position for embroidery module».  
> Follow the instructions on the display.

## Checking the Software Version



> Touch the icon «Setup Program».



> Touch the icon «Machine settings».



> Touch the icon «Information».



> Touch the icon «Version».

## Reviewing the total number of stitches



> Touch the icon «Setup Program».



> Touch the icon «Machine settings».



> Touch the icon «Information».



> Touch the icon «Version».

## Registering details of the dealer



> Touch the icon «Setup Program».



> Touch the icon «Machine settings».



> Touch the icon «Information».



> Touch the icon «Dealer details» to enter the information of the specialized dealer.



> Touch the icon «Name of the shop» to enter the name of the specialized BERNINA dealer.



> Touch the icon «Address» to enter the address of the specialized BERNINA dealer.



> Touch the icon «Phone» to enter the telephone number of the specialized BERNINA dealer.



> Touch the icon «Internet» to enter the Internet homepage or the email address of the specialized BERNINA dealer.

## Saving Service data

Service data concerning the status quo of the machine can be saved on a BERNINA USB stick (optional accessory) and then given to the BERNINA dealer this way.

> Insert a BERNINA USB stick (optional accessory) which provides enough free memory space into the USB port (1).



> Touch the icon «Setup Program».



> Touch the icon «Machine settings».



> Touch the icon «Information».



> Touch the icon «Service data».

> Touch the icon «LOG».

– The icon «LOG» is outlined in white.

> Only when the icon is not outlined in white anymore, remove the BERNINA USB Stick (optional accessory).





## 4 Creative sewing

### 4.1 Overview Sewing functions



- |   |                     |   |                 |
|---|---------------------|---|-----------------|
| 1 | Practical stitches  | 4 | Buttonholes     |
| 2 | Decorative stitches | 5 | Quilt stitches  |
| 3 | Alphabets           | 6 | Personal Memory |

#### Selecting a stitch pattern

- > Select stitch pattern, alphabet or a buttonhole.
- > Wipe up in the area of the practical stitches to have more stitch patterns displayed.
- > Touch the icon «Display all stitch patterns» (1) to scale up the view.



- > Touch the icon «Display all stitch patterns» (1) again to to downsize the stitch pattern view.
- > Touch the icon «Stitch pattern selection by number» to select the stitch pattern by entering the stitch number.



## 4.2 BERNINA Dual Feed



It is recommended to match the presser foot pressure with the fabric. The thicker the fabric, the lower the presser foot pressure.

The BERNINA Dual Feed feeds the fabric from above and from beneath simultaneously. This provides an even and careful feed forward even for smooth and thin materials. Striped and checkered patterns can be matched perfectly by even feeding.

In general, the BERNINA Dual Feed is used for the following sewing projects:

- Sewing: All sewing applications with difficult fabrics such as for seams, zippers.
- Patchwork: With accurate stripes, blocks and with decorative stitches up to a stitch width of 9 mm.
- Appliqués: sewing appliques, ribbons and bias binding.

Difficult-to-work-with fabrics are:

- Velvet, normally sewn with the grain.
- Toweling.
- Jersey, especially when sewing it crosswise to knit.
- Fake fur or coated fake fur.
- Fleece-types of fabrics.
- Batted fabrics.
- Stripes and checks.
- Curtain fabrics with pattern repeats.

«Sticky» fabrics are:

- Imitation leather, coated fabrics (Dual Feed presser foot with sliding sole).

### Application of the BERNINA Dual Feed



Only use presser feet with a cut-out at the center back and the labeling «D». Additional presser feet with the labeling «D» are listed in the enclosed accessory catalog.

- > Raise the presser foot.
- > Attach the presser foot with the labeling «D».
- > Pull the dual feed down until it engages.



- > Raise the presser foot.

- > Hold the dual feed on the holder with two fingers, pull it down, then push backward, slowly letting it slide upward.



### 4.3 Sewing speed control

The sewing speed is infinitely variable with the slide.

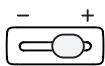

- > Move the slide to the left to reduce the sewing speed.
- > Move the slide to the right to increase the sewing speed.

### 4.4 Editing stitch patterns

#### Changing the stitch width

- > Turn the «Upper Multifunctional knob» to the left to narrow the stitch width.
- > Turn the «Upper Multifunctional knob» to the right to widen the stitch width.
- > Touch the icon «Stitch width» (1).



- > Touch the yellow-framed icon to reset the alteration to basic setting.

## Changing the stitch length

- > Turn the «Lower Multifunctional knob» to the left to shorten the stitch length.
- > Turn the «Lower Multifunctional knob» to the right to elongate the stitch length.
- > Touch the icon «Stitch length» (1).



- > Touch the yellow-framed icon to reset the alteration to basic setting.

## Adjusting the upper thread tension

The basic setting of the upper thread tension is set automatically as soon as a stitch pattern or an embroidery motif is selected.

The upper thread tension is set optimally at the BERNINA factory and the machine has been tested. Metrosene-/Seralon thread size 100/2 (Company Mettler, Switzerland) is used for upper and bobbin thread.

When of using other types of sewing or embroidery threads, the optimal tension may vary. Therefore it may be necessary to adjust the upper thread tension according to the sewing or embroidering project as well as the desired stitch pattern or the embroidery motif individually.

The higher the upper thread tension, the tighter the upper thread which means that the bobbin thread is pulled up to the top of the fabric. When the upper thread tension is low, the upper thread is less tightened which means that the bobbin thread is pulled up less.

Alterations of the upper thread tension in the Setup Program affect the currently selected stitch or embroidery patterns. Permanent alterations of the upper thread tension for the sewing mode (see page 50) and for embroidery mode (see page 54) can be made in the Setup Program.



- > Touch the icon «Upper thread tension».

- > Move the slide using the touchscreen pen or the finger to increase or to reduce the upper thread tension.



- > Touch the yellow-framed icon to reset the alteration to basic setting.

### Correcting the balance

The machine is tested and set optimally before it leaves the BERNINA factory. Different fabrics, threads and stabilizers can affect the programmed stitch patterns so that they cannot be sewn out correctly. The electronic balance can correct these deviation and the stitch pattern can be adjusted optimally to the selected fabric.

- > Select a stitch pattern or alphabet.
- > Touch the icon «i»-Dialog.



- > Touch the icon «Balance».
- > Turn the «Lower Multifunctional knob» to correct the horizontal direction of the stitch pattern.

### Programming pattern repeat

- > Select a stitch pattern or alphabet.
- > Touch the icon «i»-Dialog.



- > Touch the icon «Pattern repeat» once to repeat the stitch pattern.
- > Touch the icon «Pattern repeat» again to repeat the stitch pattern up to 9 times.
- > Keep the icon «Pattern repeat» touched to deactivate the stitch pattern repeat.

### Programming long stitch

The maximum length for long stitches is 12 mm and the machine sews every second stitch.

- > Select a stitch pattern.
- > Touch the icon «i»-Dialog.

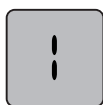

- > Touch the icon «Long stitch».
- > Touch the yellow-framed icon to reset the alteration to basic setting.

### Mirror image of stitch patterns

- > Select a stitch pattern or alphabet.
- > Touch the icon «i»-Dialog.



- > Touch the icon «Mirror image left/right» to mirror the stitch pattern from left to right.



- > Touch the icon «Mirror image up/down» to mirror the stitch pattern contrary to the sewing direction.
- > Touch the yellow-framed icon to reset the alteration to basic setting.

### Editing stitch pattern length

The stitch patterns can be lengthwise extended or shortened.

- > Select a stitch pattern or alphabet.
- > Touch the icon «i»-Dialog.



- > Touch the icon «Editing stitch pattern length».
- > Move the slide with the touchscreen pen or the finger to determine the length of the stitch pattern.
- > Touch the icon «+100%» (1) to extend the stitch pattern length in 100%-steps.



- > Touch the yellow-framed icon to reset the alteration to basic setting.

### Programming the stitch counter function

The stitch counter function cannot be applied with all stitch patterns. If, for example, the honeycomb stitch has been selected, the stitch counter function cannot be used.

- > Select a stitch pattern.
- > Touch the icon «i»-Dialog.



- > Touch the icon «Stitch counter».
- > Sew the desired length.

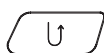

- > Press the button «Quick reverse».
  - The display changes to «Auto» and the selected stitch pattern in the new length is saved until the machine is switched off.

### Quick reverse

- > Select a stitch pattern, alphabet or buttonhole.
- > Program needle stop down (permanent) to switch immediately to Quick reverse as soon as the button «Quick reverse» is pressed.
- > Program needle stop up (permanent) to sew another stitch forward before the machine switches to reverse sewing.

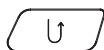

- > Press the button «Quick reverse» and keep pressed.

### Permanent Quick reverse

- > Select a stitch pattern or alphabet.
- > Touch the icon «i»-Dialog.



- > Touch the icon «Permanent reverse sewing» to sew permanently in reverse.

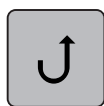

### Backstepping

- > Select a stitch pattern, alphabet or a buttonhole.
- > Touch the icon «i»-Dialog.



- > Touch the icon «Backstepping» to backstep the last 200 stitches.



## 4.5 Securing

### Securing with the button «Pattern end»

The button «Pattern end» can be programmed with various functions.



- > Press the button «Pattern end» before sewing is started or while sewing.
  - While sewing, a stop icon indicates that the function is activated and the stitch pattern or the current combination of a stitch pattern will be secured at the end with the programmed number of stitches.

### Securing via the icon «Securing»

Every single pattern of a stitch pattern combination can be secured either at the beginning or at the end.

- > Touch the icon «i»-Dialog.



- > Touch the icon «Securing» before starting to sew.
  - The stitch pattern/stitch pattern combination is secured with 4 stitches at the beginning.
- > Touch the icon «Securing» while sewing.
  - The stitch pattern or the active stitch pattern of the stitch pattern combination is secured with 4 stitches at the end.

## 4.6 Administering stitch patterns

### Saving settings of stitch patterns

- > Select a stitch pattern, alphabet or buttonhole.
- > Touch the icon «i»-Dialog.
- > Edit the stitch, alphabet or buttonhole.



- > Touch the icon «Saving stitch pattern settings» to save the alterations permanently.



- > Touch the icon «Back to basic setting» to cancel the alterations.

### Saving stitch patterns in personal memory

In the filing system «Personal memory» any stitch patterns, also those which have been individually edited, can be saved. In every file up to maximal 100 stitch patterns can be saved.

- > Select a stitch pattern, alphabet or buttonhole.
- > Edit the stitch pattern.
- > Touch the icon «Personal memory».



- > Touch the icon «Saving stitch pattern».
- > Select the file where the pattern is to be saved.



- > Touch the icon «Confirm».

### Overwriting stitch patterns from the personal memory

Prerequisite:

- The stitch pattern is saved in the personal memory.
- > Select a stitch pattern, alphabet or buttonhole.
- > Edit the stitch pattern.
- > Touch the icon «Personal memory».



- > Touch the icon «Saving stitch pattern».
- > Select the file where the stitch pattern to be overwritten has been saved.
- > Select the stitch pattern which should be overwritten.



- > Touch the icon «Confirm».

### Loading stitch patterns from the personal memory

Prerequisite:

- The stitch pattern is saved in the personal memory.
- > Touch the icon «Personal memory».







- > Touch the icon «Stitch pattern selection».
- > Select the file where the stitch pattern has been saved.
- > Select a stitch pattern.

### Deleting stitch patterns from the personal memory

Prerequisite:

- The stitch pattern is saved in the personal memory.



- > Touch the icon «Personal memory».



- > Touch the icon «Delete».
- > Select the file where the stitch pattern has been saved.
- > Select a stitch pattern.



- > Touch the icon «Confirm» to delete the stitch pattern.

### Canceling alterations

Any alterations of stitch patterns can be reset to basic setting, except for those stitch patterns which have been saved in the personal memory.



- > Touch the icon «clr».

## 4.7 Combi mode

### Overview Combi mode



- |   |  |   |  |
|---|--|---|--|
| 1 | Stitch width of the active stitch pattern  | 3 | Combi mode/Single mode                         |
| 2 | Stitch length of the active stitch pattern | 4 | Individual stitch pattern within a combination |

### Creating Stitch pattern combinations

In the Combi mode stitch patterns and alphabets can be combined according to your wish. By combining any alphabet letters, the logo BERNINA can be created.



- > Touch the icon «Single/Combi mode».

> Select the desired stitch patterns.



> Touch the icon «Single/Combi mode» again to return to the single mode.

### Saving a stitch pattern combination

> Create a stitch pattern combination.

> Touch the icon «Personal memory».



> Touch the icon «Saving the stitch pattern».



> Touch the icon «Confirm» or the yellow-framed icon to save the stitch pattern combination.

### Loading a stitch pattern combination



> Touch the icon «Single/Combi mode».



> Touch the icon «Personal memory».



> Touch the icon «Selection of stitch pattern combination».

> Select a stitch pattern combination.

### Overwriting a stitch pattern combination

> Create a stitch pattern combination.

> Touch the icon «Personal Memory».



> Touch the icon «Saving the stitch pattern».

> Select the stitch pattern combination which is to be overwritten.



> Touch the icon «Confirm» to overwrite the stitch pattern combination.

### Deleting a stitch pattern combination

> Create Create a stitch pattern combination.

> Touch the icon «i»-Dialog.



- > Touch the icon «Editing the whole combination».
- > Touch the icon «Delete».
- > Touch the icon «Confirm».

### Editing a single stitch pattern

- > Create a stitch pattern combination.
- > With the touchscreen pen or the finger touch the desired position (1) within the stitch pattern combination to select a single stitch pattern.



- > Touch the icon «i»-Dialog to edit the single stitch pattern.

### Deleting a single stitch pattern

- > Create a stitch pattern combination .
- > With the touchscreen pen or the finger touch the desired position (1) within the stitch pattern combination to select a single stitch pattern.





> Touch the icon «i»-Dialog.



> Touch the icon «Delete» to delete the single stitch pattern.

### Adding a single stitch pattern

The new stitch pattern is always added **after** the selected stitch pattern.

- > Create a stitch pattern combination.
- > With the touchscreen pen or the finger touch the desired position (1) within the stitch pattern combination to select a single stitch pattern.



> Select a new stitch pattern.

### Mirroring a stitch pattern combination

- > Create a stitch pattern combination.
- > Touch the icon «i»-Dialog.

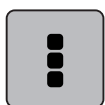

> Touch the icon «Editing the complete combination».



- > Touch the icon «Mirror image left/right» to mirror the complete stitch pattern combination horizontally.
- > Touch the icon «Mirror image left/right» again to reset the alterations to basic setting.

### Stitch pattern combination Subdivider 1

A stitch pattern combination can be subdivided into several sections. The subdivision is placed **beneath** the cursor. Only this section is sewn where the cursor is placed. To sew the next section, the cursor must be placed in the next section.

- > Create a stitch pattern combination.
- > With the touchscreen pen or the finger select the desired position within the stitch pattern combination where the stitch pattern combination is to be subdivided.



- > Touch the icon «i»-Dialog.



- > Touch the icon «Editing the combination at cursor position».

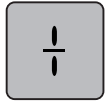

- > Touch the icon «Subdividing the combination».

## Stitch pattern combination Subdivider 2

A stitch pattern combination can be interrupted at various sections. The interruption is placed **beneath** the cursor.

- > Create a stitch pattern combination.
- > With the touchscreen pen or the finger select the desired position within the stitch pattern combination where the stitch pattern combination is to be interrupted.
- > Touch the icon «i»-Dialog.

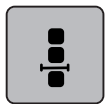

- > Touch the icon «Editing the combination at cursor position».

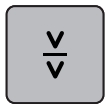

- > Touch the icon «Interrupting the combination».
- > Sew the first section and then reposition the fabric.

## Securing a stitch pattern combination

- > Create a stitch pattern combination.
- > With the touchscreen pen or the finger select the desired position within the stitch pattern combination where the stitch pattern combination is to be secured.
- > Touch the icon «i»-Dialog.

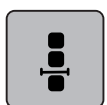

- > Touch the icon «Editing the combination at cursor position».



- > Touch the icon «Securing».
  - Every single pattern of the stitch pattern combination can be secured at the start or at the end.

## Programming pattern repeat

- > Create a stitch pattern combination.
- > Touch the icon «i»-Dialog.

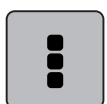

- > Touch the icon «Editing the complete combination».



- > Touch the icon «Pattern repeat» once to repeat the stitch pattern combination.
- > Touch the icon «Pattern repeat» again to repeat the stitch pattern combination up to 9 times.
- > Keep the icon «Pattern repeat» pressed to deactivate the pattern repeat.

#### 4.8 Height Compensation of uneven layers

If the presser foot is at an angle when sewing over a thick seam, the feed dog cannot grip the fabric and the sewing project cannot be sewn out properly.

- > Place 1 – 3 compensating plates as required from the back of the presser foot close to the needle to level the fabric layer.

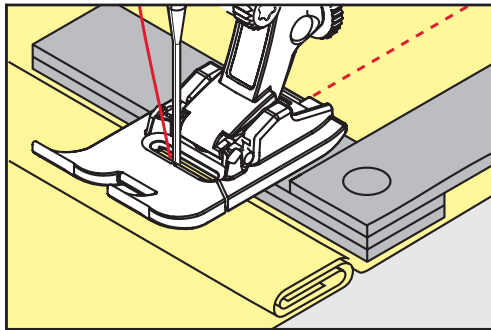

- The presser foot is leveled with the sewing project.

- > Place 1 – 3 compensating plates as required from the front of the presser foot close to the needle to level the fabric layer.

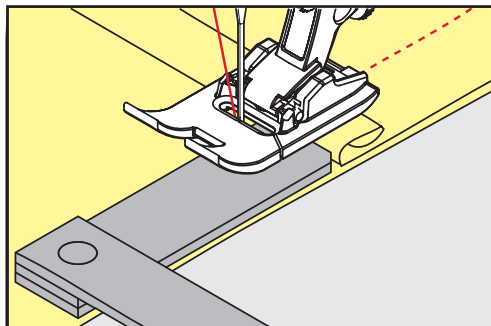

- The presser foot is leveled with the sewing project.

- > Sew until the complete presser foot has passed the thick seam.
- > Remove the plates of the height compensation.

#### 4.9 Sewing Corners

When sewing corners, only a small section of the fabric is actually on the feed dog. Therefore it cannot grip the fabric well. By means of the height compensation tool the fabric can be fed evenly.

- > When the fabric edge is reached, stop the sewing process with needle position down.
- > Raise the presser foot.
- > Turn the fabric and place in desired position.
- > Place 1 – 3 compensating plates as required on the right of the presser foot close to the sewing project.

- > Lower the presser foot.

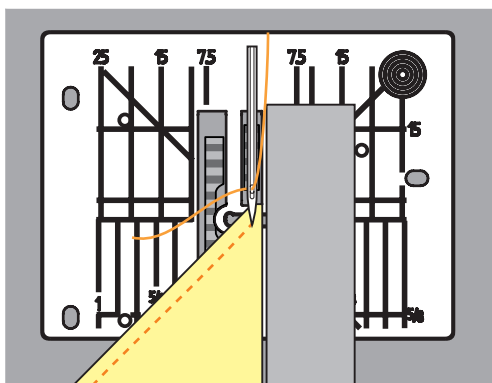

- > Resume sewing until the sewing project is on the feed dog again.

#### 4.10 Using eco mode















During a longer interruption of work the machine can be set into a power save mode. The power save mode also serves as a child safety feature. Nothing can be selected in the display and the machine cannot be started.



- > Touch the icon «eco».
  - The display goes to sleep. The power consumption is reduced and the sewing light is off.
- > Touch the icon «eco» again.
  - The machine is ready for use.

## 5 Practical stitches

### 5.1 Overview Practical stitches

Stitch patterns	Stitch number	Name	Description
	1	Straight stitch	Sewing and topstitching.
	2	Zig zag	Reinforcing seams, overcasting edges, sewing elastic seams and attaching lace.
	3	Vari overlock	Sewing and finishing in one step of elastic fabrics.
	4	Running stitch	Darning with running stitch, mending fabrics, reinforcing edges.
	5	Securing Program	Securing starts and ends of seams by straight stitching.
	6	Triple Straight stitch	Reinforced seams in heavy fabrics; visible hems and seams.
	7	Triple Zig zag	Reinforced seams in heavy fabrics; visible hems and seams.
	8	Honeycomb stitch	For stretch fabrics and hems. Is also used with elastic thread in the bobbin.
	9	Blind stitch	Blind hems, shell edging effect on soft jerseys and fine material, decorative seams.
	10	Double overlock	Sewing and finishing in one step of elastic fabrics.
	11	Super stretch stitch	For highly stretch fabrics. For all types of clothing.
	12	Gathering stitch	Most types of fabric; gathering with shirring elastic, butted seams = butting two pressed edges and sewing together, decorative stitches.
	13	Stretch overlock	Sewing and finishing in one step of elastic fabrics.
	14	Tricot stitch	Visible hems, visible seams in lingerie, sweaters, mending jersey.





## 5.2 Sewing straight stitch

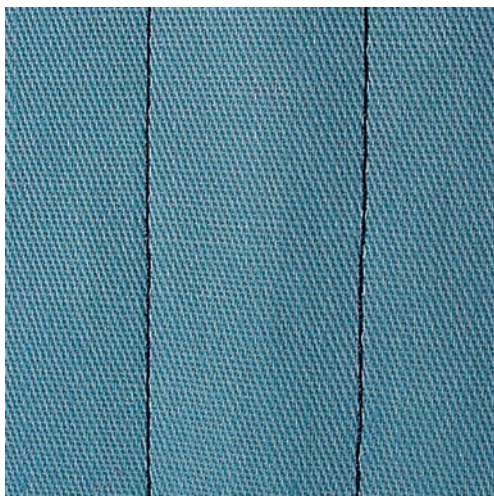

Match the stitch length with the sewing project, such as for denim fabrics use long stitches (ca. 3 – 4 mm), for delicate fabrics use short stitches (ca. 2 – 2.5 mm). Match the stitch length with the thread size, such as when edgestitching with Cordonnet, use long stitches (ca. 3 – 5 mm).

The straight stitch, also called step stitch, is the most used stitch.

Prerequisite:

- The Reverse pattern foot No. 1C/1D is attached.



- > Touch the icon «Practical stitches».
  - The Straight stitch No. 1 is selected automatically.

## 5.3 Securing with the automatic Securing Program

Due to a determined number of 5 stitches sewn forward and 5 stitches sewn backward, the securing is regular.

Prerequisite:

- The Reverse pattern foot No. 1C is attached.



- > Touch the icon «Practical stitches».
- > Select the Securing Program No. 5.
- > Press the foot control.
  - The machine secures automatically.
- > Sew the seam in the desired length.

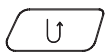

- > Press the button «Quick reverse».
  - The machine secures automatically and stops at the end of the securing program.

## 5.4 Sewing in the zipper

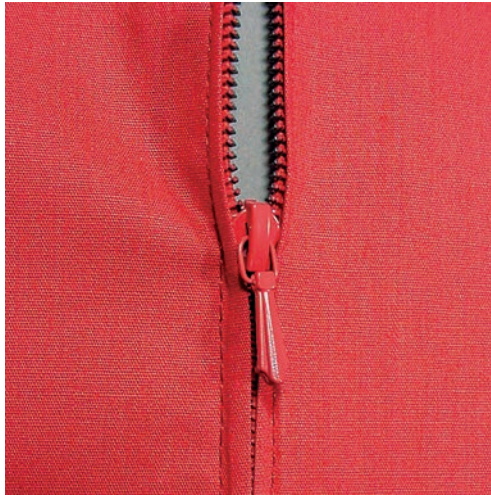

As the fabric feed can be difficult when starting to sew, it is recommended to hold the threads firmly or to pull the fabric slightly to the back for a few stitches or to sew 1 - 2 cm reverse first.



- > Attach the Reverse pattern foot No. 1C.
- > Touch the icon «Practical stitches».
  - The Straight stitch No. 1 is selected automatically.
- > Sew the seam up to where the zipper starts.
- > Sew the securing stitches.
- > Close the zipper length with long stitches.
- > Finish the seam allowances.
- > Iron the seam.
- > Open the zipper length.
- > Baste the zipper under the fabric so that the fabric folded edges meet over the center of the zipper.
- > Open the zipper a few centimeters.
- > Attach the Zipper foot No. 4D.
- > Move the needle position to the right.
- > Use the Free Hand System to raise the presser foot and to position the sewing project.
- > Start sewing from top left.
- > Guide the foot so that the needle stitches along the zipper coils.
- > Stop in front of the zipper pull with needle position down.
- > Raise the presser foot.
- > Close the zipper.
- > Continue to sew and stop in front of the base of the zipper with needle position down.
- > Raise the presser foot and turn the sewing project.
- > Sew across the other side of the zipper and stop with needle position down.
- > Raise the presser foot and turn the sewing project.
- > Sew the second side from bottom to top.

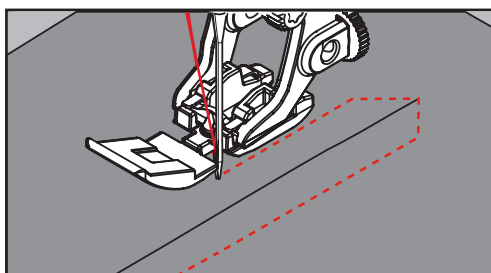

## 5.5 Sewing both sides of the zipper from bottom to top

It is recommended to sew in the zipper on both sides from bottom to top. This alternative is suitable for all the fabric with nap such as velvet.



When the fabric is firm or densely woven, it is recommended to use a needle with the size 90 – 100. This results in an even stitch formation.



- > Attach the Reverse pattern foot No. 1C.
- > Touch the icon «Practical stitches».
  - The Straight stitch No. 1 is selected automatically.
- > Sew the seam up to the zipper beginning.
- > Sew the securing stitches.
- > Close the zipper length with long stitches.
- > Finish the seam allowances.
- > Iron the seam.
- > Open the zipper length.
- > Baste the zipper under the fabric so that the fabric folded edges meet over the center of the zipper.
- > Attach the Zipper foot No. 4D.
- > Move the needle position to the right.
- > Use the Free Hand System to raise the presser foot and to position the sewing project.
- > Start sewing in the center of the seam at the end of the zipper.
- > Sew diagonally along the edge of the zipper coils.
- > Sew the first side (1) from bottom to top.
- > Stop in front of the zipper pull with needle position down.
- > Raise the presser foot.
- > Open the zipper as far as behind the presser foot.
- > Lower the presser foot and continue sewing.
- > Sew the second side (2) in exactly the same way from bottom to top.

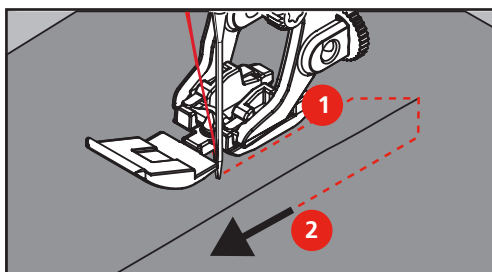

## 5.6 Sewing triple straight stitch



The triple straight stitch is especially suitable for durable seams and for firm, densely woven fabrics such as denim and corduroy. For firm or densely woven materials it is recommended to attach the Jeans foot No. 8. This will help to sew denim or canvas. For decorative topstitching the stitch length can be elongated.

- > Attach the Reverse pattern foot No. 1C/1D.
- > Touch the icon «Practical stitches».
- > Select the Triple straight stitch No. 6.



## 5.7 Sewing Triple zig zag

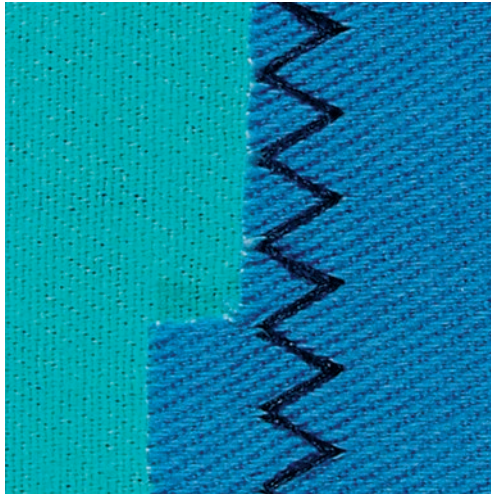

For firm materials such as denim, deckchair covers, awnings or frequently washed items. Finish raw edges first.

- > Attach the Reverse pattern foot No. 1C/1D.
- > Touch the icon «Practical stitches».
- > Select the Triple zig zag No. 7.



## 5.8 Manual darning

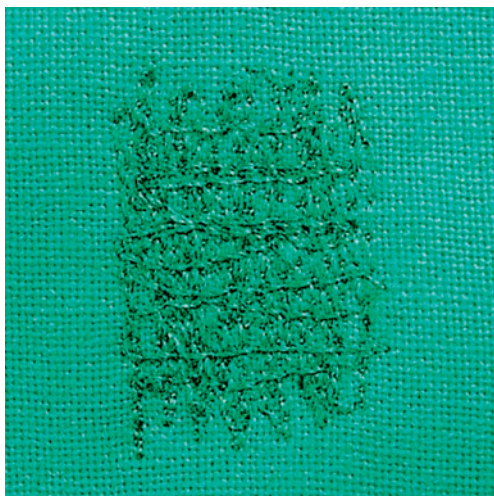

Used for darning holes or worn areas in all fabric types.

If the thread is lying on top and a poor stitch formation results, slow down the movement of the sewing project. If there are knots on the wrong side of the fabric, move the sewing project faster. When the thread breaks, guide the sewing project more consistently.



- > Attach the Darning foot No. 9 (optional accessory).
- > Touch the icon «Practical stitches».
  - The Straight stitch No. 1 is selected automatically.
- > Lower the feed dog.
- > Attach the slide-on table.
- > Hoop the sewing project in the round embroidery hoop (optional accessory).
  - The darning area stays evenly taut and cannot be distorted.
- > Sew from the left to the right, guide the fabric evenly by hand without using pressure.
- > Move in curves when changing the direction to avoid holes and thread breakage.
- > Work the rows in irregular lengths so that the thread is better spread over the fabric.

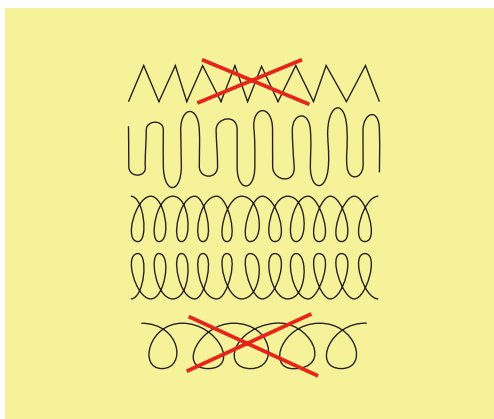

- > Sew the first rows not too close together and beyond the worn area.



- > Sew the rows in irregular lengths.

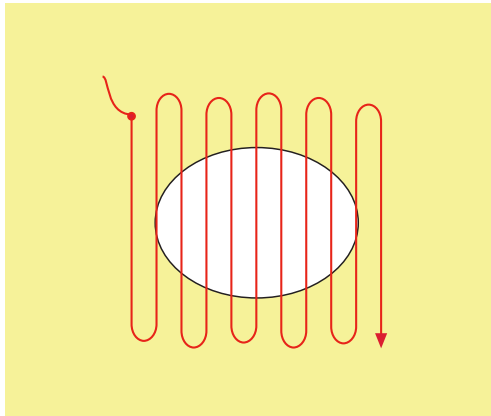

- > Turn the sewing project by 90°.
- > Sew the first rows not too close.

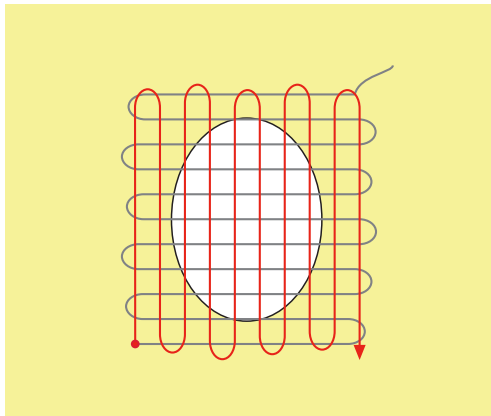

- > Turn the sewing project by 180°.
- > Sew another loose row.

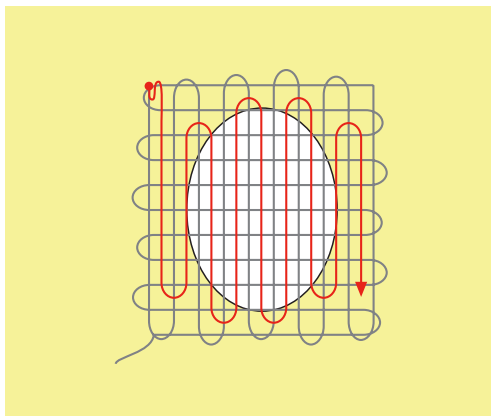

## 5.9 Automatic darning



The simple Darning Program No. 22 is especially suitable for quick darning of worn or damaged areas. It is recommended to use fine material as a backing for the worn and damaged areas or to stick an adhesive interlining. The simple Darning Program No.22 replaces threads along the lengthwise grain in all materials. If the darning area becomes distorted, correct with the balance.

- > Attach the Reverse pattern foot No.1C or the Buttonhole foot No. 3A.
- > Touch the icon «Practical stitches».
- > Select the simple Darning Program No. 22.
- > Hoop light weight materials in the round embroidery hoop (optional accessory).
  - The darning area stays evenly taut and cannot be distorted.
- > Start sewing top left.
- > Sew the first row.
- > Stop the machine.
- > Press the button «Quick Reverse».
  - The length is programmed.
- > Finish sewing the Darning Program.
  - The machine stops automatically.

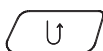

## 5.10 Reinforced darning, automatic







## 5.12 Sewing Double overlock



A double overlock seam is suitable for loose knits and cross seams in knits. When working with jersey, a jersey needle should be used to prevent damaging the knit fabric. When sewing stretch materials, use a stretch needle.

- > Attach the Reverse pattern foot No. 1C or the Overlock foot No. 2A.
- > Touch the icon «Practical stitches».
- > Select the Double overlock No. 10.



## 5.13 Narrow edgestitching

- > Attach the Blindstitch foot No. 5 (optional accessory) or the Reverse pattern foot No. 1C or the Edge stitch foot No. 10/10C/10D (optional accessory).
- > Touch the icon «Practical stitches».
  - The Straight stitch No. 1 is selected automatically.
- > Place the edge on the left against the guide of the Blindstitch foot.
- > Select the needle position left in the desired distance to the edge.

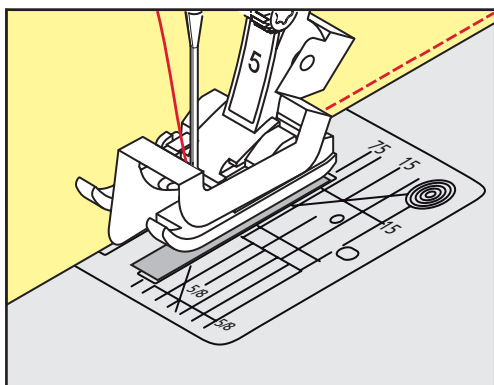

## 5.14 Wide edgestitching

- > Attach the Blindstitch foot No. 5 (optional accessory) or the Reverse pattern foot No. 1C or the Edge stitch foot No. 10/10C/10D (optional accessory).
- > Touch the icon «Practical stitches».
  - The Straight stitch No. 1 is selected automatically.
- > Guide the folded edge at a distance of 1 – 2.5 cm along either the presser foot or the marks.



- > Select the needle position in the desired distance to the edge.

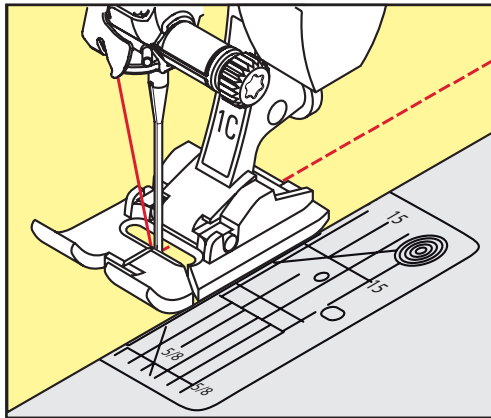

### 5.15 Edgestitching using the seam guide

When sewing parallel wider lines, it is recommended to guide the seam guide along the sewn of lines.

- > Attach the Reverse pattern foot No. 1C or the Edge stitch foot No. 10/10C/10D (optional accessory).
- > Touch the icon «Practical stitches».
  - The Straight stitch No. 1 is selected automatically.
- > Loosen the screw on the back of the presser foot.
- > Insert the seam guide into the hole of the presser foot.
- > Adjust the width as desired.
- > Tighten the screw.
- > Guide the folded edge along the seam guide.

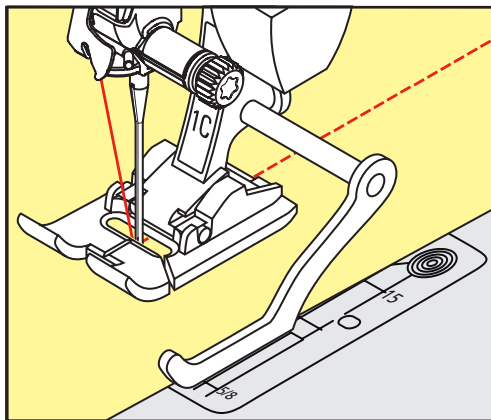

### 5.16 Sewing hem edges

When using the Blindstitch foot No. 5 (optional accessory), it is recommended to select a needle position far left or far right. When using the Reverse pattern foot No. 1C or the Edge stitch foot No. 10/10C/10D (optional accessory) all needle positions are possible.

- > Attach the Blindstitch foot No. 5 (optional accessory) or the Reverse pattern foot No. 1C or the Edge stitch foot No. 10/10C/10D (optional accessory).
- > Touch the icon «Practical stitches».
  - The Straight stitch No. 1 is selected automatically.
- > Place the inside upper edge right against the guide of the Blindstitch foot.



- > Choose the needle position far right to sew along the upper edge.

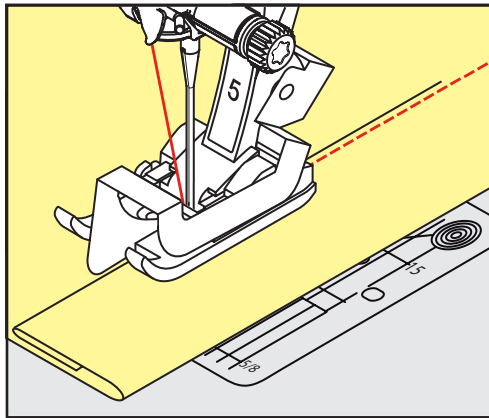

### 5.17 Sewing blind hems

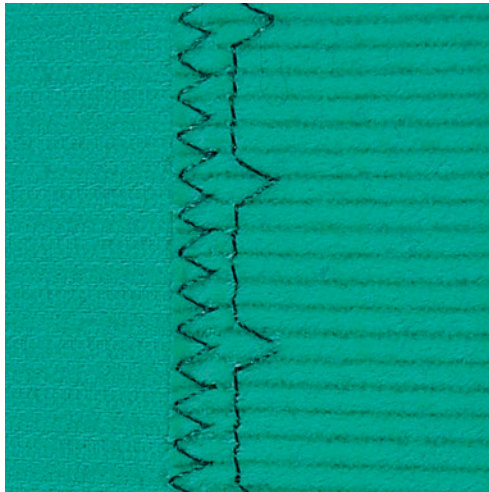

For invisible hems in medium to heavy weight cotton, wool and blended materials.

Prerequisite:

- The raw edges are finished.
- > Attach the Blindstitch foot No. 5 (optional accessory).
- > Touch the icon «Practical stitches».
- > Select the Blindstitch No. 9.
- > Fold the fabric back over the right side of the fabric to expose the finished lower edge.
- > Place the fabric under the presser foot and move the folded edge against the metal guide on the presser foot.
- > Guide the folded edge evenly along the metal guide of the foot to sew the stitches evenly deep.
  - Make sure that the needle only pierces the edge of the fold.



- > Check the blind hem on both fabric sides again after about 10 cm and adjust the stitch width if necessary.

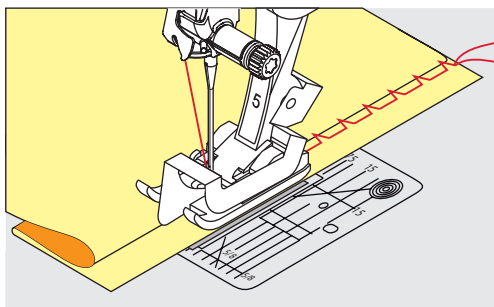

### 5.18 Sewing visible hems

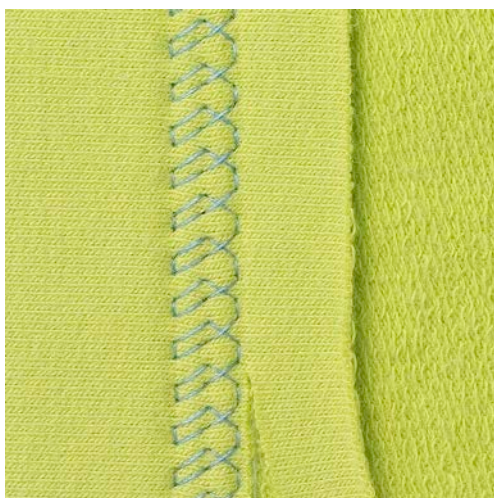

The visible hem is especially suitable for elastic hems in jersey, cotton, wool, synthetic and mixed fibers.



- > Attach the Reverse pattern foot No. 1C/1D.
- > Touch the icon «Practical stitches».
- > Select Tricot stitch No. 14.
- > Iron the hem and baste if necessary.
- > Reduce the presser foot pressure if necessary.
- > Sew the hem at the preferred depth on the right side.
- > Trim the excess fabric from the wrong side.

## 5.19 Sewing flat joining seams

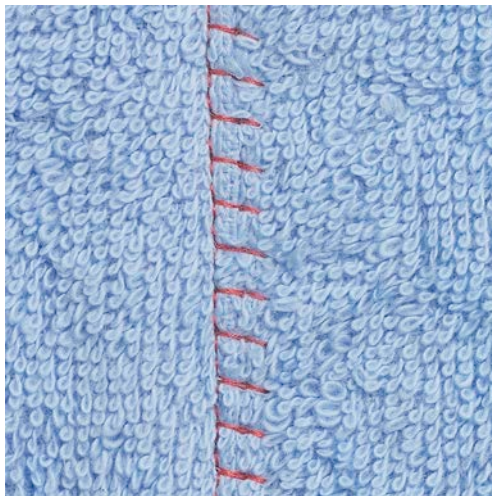

The flat joining seam is especially suitable for or thick materials such as terry cloth, felt and leather.



- > Attach the Reverse pattern foot No. 1C.
- > Touch the icon «Practical stitches».
- > Select the Stretch overlock No. 13.
- > Overlap the fabric edges.
- > Sew along the fabric edge.
- > The needle stitches over the edge of the top layer on the right side into the bottom layer to get a very flat durable seam.

## 5.20 Sewing basting stitches

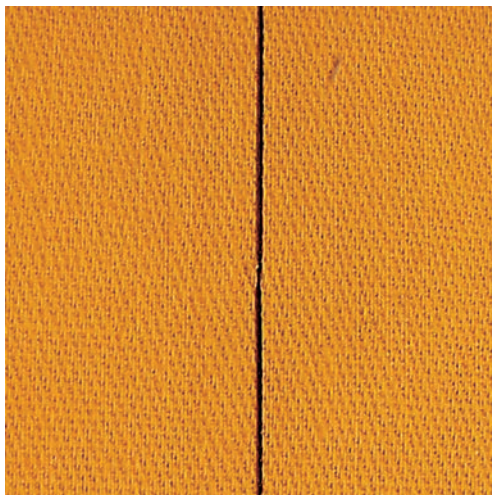

When sewing basting stitches, it is recommended to use a fine darning thread as this is easier to remove. With the Basting stitch No. 21 only every fourth stitch is sewn. The longest stitch possible is 24 mm when the stitch length is set at 6 mm. The recommended stitch length is 3.5 – 5 mm. The basting stitch is suitable for sewing projects where a very long stitch length is required.



- > Attach the Reverse pattern foot No. 1C/1D.
- > Touch the icon «Practical stitches».
- > Select the Basting stitch No. 21.
- > Select the stitch length.
- > Pin the fabric layers at a right angle to basting direction to prevent the layers from slipping.
- > Sew 3-4 basting stitches at the begin and at the end.



## 6 Decorative stitches

### 6.1 Overview Decorative Stitches

Depending on the type of material, simple or more complex decorative stitches should be selected to best suit the fabric.

- Decorative stitches which are programmed with simple straight stitches are particularly appropriate for light weight materials, such as the Decorative stitch No. 101.
- Decorative stitches which are programmed with triple straight stitches or with a few satin stitches are particularly appropriate for medium weight materials, such as the Decorative stitch No. 107.
- Decorative stitches which are programmed with satin stitches are particularly appropriate for heavy materials, such as the Decorative stitch No. 401.

For a perfect stitch formation it is of advantage to use the same thread color for upper and bobbin thread and a stabilizer. With pile or longfiber materials it is recommended to use an additional, water-soluble stabilizer on the right side which can be easily removed after sewing.

Decorative stitch	Category	Name
	Category 100	Florals
	Category 300	Cross stitches
	Category 400	Satin stitches
	Category 600	Ornamental stitches
	Category 700	Heirloom stitches
	Category 900	Novelty

## 6.2 Bobbin-Play

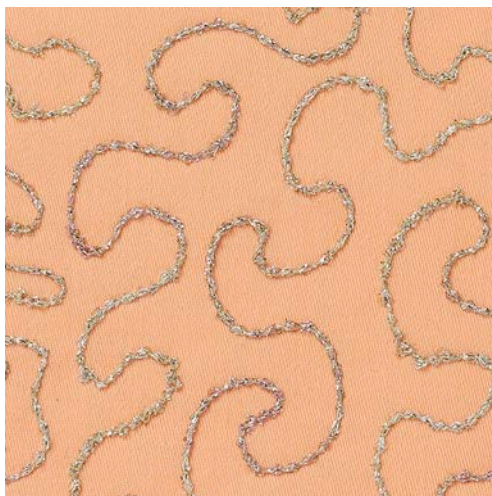

NOTICE Inappropriate bobbin case is used.

Damage of the bobbin case.

> Use the special bobbin case (optional accessory).

The bobbin can be filled with different thread material. For free-motion stitching to add texture. This method is similar to «normal» free-motion sewing, but is done on the **wrong** side of the fabric.

Reinforce the area to be sewn with embroidery stabilizer. The design can be drawn on the wrong side of the fabric. You can also draw the design on the front side of the fabric. The lines can be followed with a freely guided straight stitch using polyester, cotton or rayon thread. The rows of stitching are visible on the right side of the fabric, and serve as reference lines for the bobbin-thread sewing.

The BSR function can be used for bobbin-thread sewing. It is recommended to guide your project at consistent speed evenly under the needle, following the lines of the design. The stabilizer must be removed after sewing.

Sew a sample first to check what the result looks like on the wrong side of the fabric.

Not all decorative stitches are suitable for this technique. Simple decorative stitches provide best results.

Avoid compact stitch types and satin stitches.

> Attach the Embroidery No. 20C or No. 20D (optional accessory).

> Touch the icon «Decorative stitches».

> Select an appropriate decorative stitch.

> Turn the «Upper Multifunctional knob» and the «Lower Multifunctional knob» to adjust the stitch length and the stitch width so that even when sewing with thick thread a nice stitch formation can be achieved.

> Touch the icon «i»-Dialog.

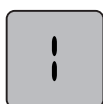

> Touch the icon «Long stitch» so that the stitch pattern is sewn less densely.

> Touch the icon «Upper thread tension» to adjust the upper thread tension if necessary.



### 6.3 Altering the stitch density

With certain decorative stitches (e. g. No. 401) the stitch density can be altered. If the stitch density is increased, the stitch distance is enlarged. If the stitch density is decreased, the stitch distance is shortened. The programmed length of the stitch pattern is not affected.

- > Select a decorative stitch.
- > Touch the icon «i»-Dialog.



- > Touch the icon «Altering the stitch pattern length».
- > Adjust the stitch density via the icons (1) «-» or «+».



- > Touch the yellow-framed icon to reset the alteration to basic setting.

## 6.4 Sewing cross stitches

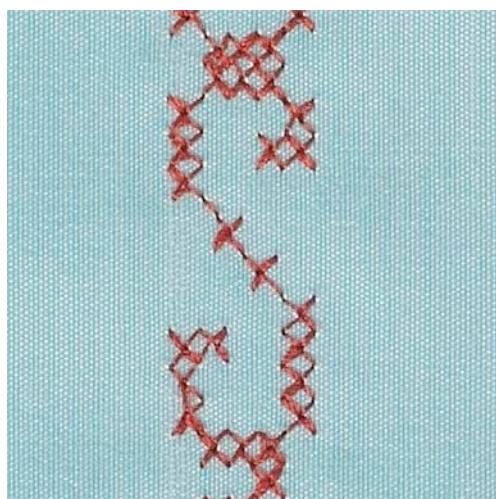
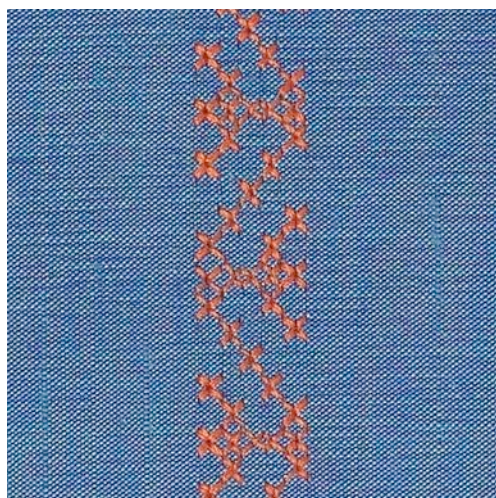

Cross stitching is a traditional technique, and extends the range of decorative stitches. If the cross stitches are sewn on fabric with a linen texture, they look like hand-stitched cross stitching. When cross stitches are sewn with cotton embroidery thread, the stitch pattern appears fuller. Cross stitches are particularly used for home furnishing, trimmings on garments and embellishing in general. As every following line refers to the first row, it is important to stitch the first row in a straight line.





- > Attach the Reverse pattern foot No. 1C/1D or the Open Embroidery foot No. 20C or the Embroidery foot No. 20D (optional accessory).
- > Select a cross stitch of the Category 300 and combine it as desired.
- > Stitch the first row using the seam guide or slide-on table seam guide to sew a straight line.
- > Stitch the second row next to the first at a distance of one presser foot's width or using the seam guide.

## 6.5 Pintucks

### Pintucks

This technique reduces the size of the fabric which means that always enough fabric should be calculated. Pintucks are narrow stitched folds which are normally sewn on the fabric before cutting out the pieces for garments or other sewing projects. They are suitable for embellishing or in combination with other heirloom embroidery techniques.

A more distinctive and relief-like effect can be achieved when the pintucks are corded, which means that they are sewn with an additional pintuck cord. Chose a pintuck cord that fits well into the grooves of the selected pintuck foot. The cord must be colorfast and shrinkproof.

Pintuck foot	Number	Description
	30 (optional accessory) 3 grooves	4 mm double needle: for heavy fabrics.
	31 (optional accessory) 5 grooves	3 mm double needle: for heavy to medium weight fabrics.
	32 (optional accessory) 7 grooves	2 mm double needle: or light to medium weight fabrics.
	33 (optional accessory) 9 grooves	1 or 1.6 mm double needle: for very light fabrics (without pintuck cord).
	46C (optional accessory) 5 grooves	1.6 – 2.5 mm double needle: for light to medium weight fabrics.

### Inserting the cord

- > Switch the machine off and disconnect it from the power supply system.
- > Remove the needle.
- > Remove the presser foot.
- > Remove the stitch plate.
- > Open the bobbin cover.
- > Pull the cord through the hook opening from the bottom and through the opening of the stitch plate.
- > Replace the stitch plate.
- > Close the bobbin cover.

- > Make sure that the cord slides through the thread slot of the bobbin cover.

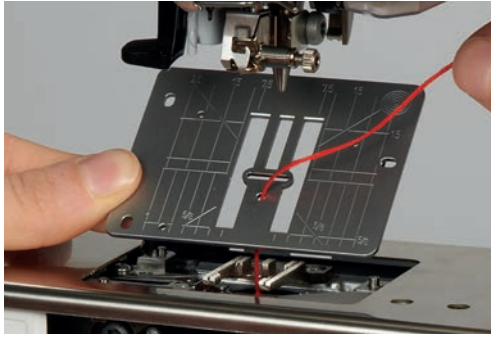

- > Place the cord spool on the arm of the Free Hand System.

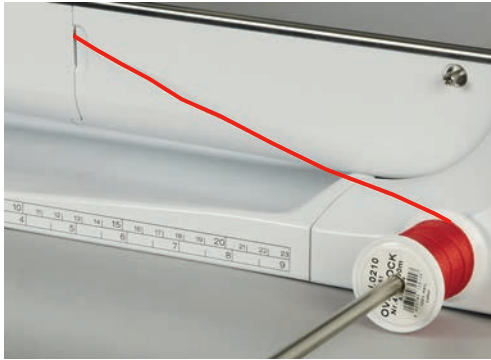

- > Check that the cord runs smoothly.
- > If the thread doesn't slide smoothly past the bobbin cover, open the cover while sewing and turn off the bobbin thread indicator in the Setup Program.

### Sewing Pintucks

The cord lies on the wrong side of the material and is hold/sewn over by the bobbin thread.

- > Sewing the first pintuck.
- > Place the first pintuck in one of the side grooves in the presser foot.
- > Sew additional pintucks parallel.



## 7 Alphabets

### 7.1 Overview Alphabet

Block, Double block, Script and Comic alphabets as well as as Cyrillic can be sewn in two different sizes.

Block, Double block, Script and Comic alphabets as well as as Cyrillic can also be sewn in lower case letters.

For a perfect stitch formation it is recommended to use the same thread color for upper and bobbin threads.

The fabric can be reinforced with embroidery stabilizer on the wrong side. Use an additional, water-soluble stabilizer on the right side of pile or napped fabrics.

Stitch patterns	Name
ABCabc	Block alphabet
ABCabc	Double-Block
<i>ABCabc</i>	Script (Italics)
ABCabc	Quilt font
АБВабв	Cyrillic
あいう	Hiragana

### 7.2 Creating lettering



- > Touch the icon «Alphabets».
- > Select the font.



- > Touch the icon «Single/Combi mode» to create a combination.
- > Touch the icon «Adjusting the view» (1) to open the expanded enter mode.



- > Select the letters.

- > Touch the icon (1) (standard setting) to use upper case letters.
- > Touch the icon (2) to use lower case letters.
- > Touch the icon (3) to use numbers and mathematic symbols.
- > Touch the icon (4) to use special characters.



- > Touch the icon «DEL» to delete single letters of the entered text.
- > Touch the icon «Adjusting the view» again to close the expanded enter mode.

### 7.3 Altering font size

Block, Double block, Script and Comic alphabets as well as as Cyrillic can also be downsized.



- > Select the icon «Alphabets».
- > Select the font.
- > Select the letters.



- > Touch the icon «i»-Dialog.

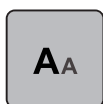













- > Touch the icon «Altering font size» to downsize the font size.
- > Touch the icon «Altering font size» again to scale up the font size up to 9 mm.



## 8 Buttonholes

### 8.1 Overview Buttonholes

To create the correct buttonhole for every button, every purpose and for every garment, your BERNINA 770 QE is equipped with a considerable collection of buttonholes. The corresponding button can be sewn on automatically. Eyelets can also be sewn.

Buttonhole	Buttonhole number	Name	Description
	51	Standard buttonhole	For light to medium weight fabrics; blouses, dresses, bedlinens.
	52	Standard buttonhole narrow	For light to medium weight fabrics; blouses, dresses, children's and baby clothes, crafts.
	53	Stretch buttonhole	For any highly elastic jersey made from cotton, wool, silk and synthetic fibers.
	54	Round buttonhole with normal bartack	For medium to heavy weight fabrics: dresses, jackets, coats, rainwear.
	56	Keyhole buttonhole	For heavy weight, non-stretch fabrics; jackets, coats, leisure wear.
	57	Keyhole buttonhole with pointed bartack	For heavy weight, non-stretch fabrics; jackets, coats, leisure wear.
	59	Straight stitch buttonhole	Program for staystitching buttonholes, for pocket openings, reinforcing buttonholes, especially for buttonholes in leather and imitation leather.
	63	Heirloom buttonhole	For light to medium weight woven fabrics; blouses, dresses, leisure wear, bedlinens.
	64	Double-rounded buttonhole	For medium to heavy weight fabrics made of various material.
	65	Double-rounded Heirloom	For light to medium weight materials; blouses, dresses, bedlinens.
	69	Decorative buttonhole with double pointed bartack	For decorative buttonholes in firmer, non-elastic fabrics.
	60	Button sew-on program	For buttons with 2 and 4 holes.



Buttonhole	Buttonhole number	Name	Description
	61	Eyelet with small zig zag	Openings for cords and narrow ribbons, for decorative work.
	62	Straight-stitch eyelet	Openings for cords and narrow ribbons, decorative work.

## 8.2 Making use of the height compensation tool

When a buttonhole is to be sewn at right angles to the project edge, it is recommend to use the height compensation plates (optional accessory).

- > Place the plates from the back between the sewing project and the bottom of the slide to the thick part of the sewing project.

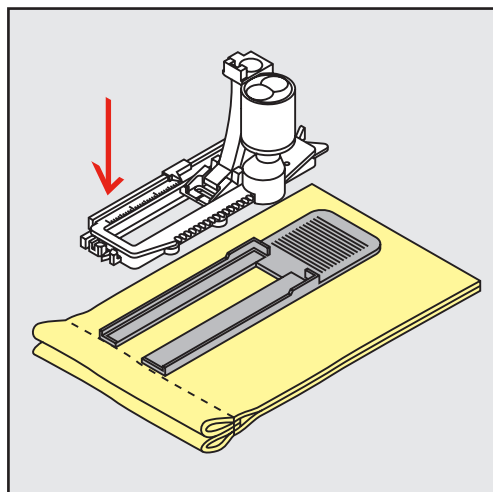

- > Lower the presser foot.

## 8.3 Using the compensation plate

When sewing a buttonhole in difficult materials, it is recommended to use the compensation plate for buttonholes (optional accessory). It can be used along with the Buttonhole foot No. 3A.

- > Insert the compensation plate carefully from the side.

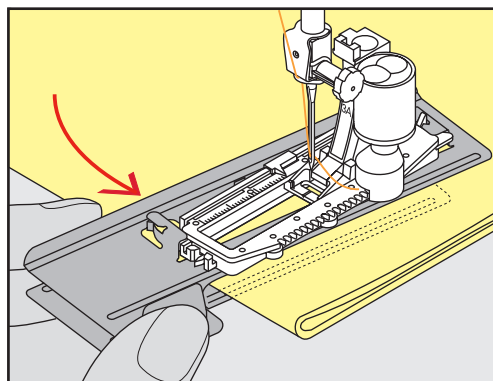



## 8.4 Marking buttonholes

- > For the buttonholes to be sewn manually, mark the position and the length on the fabric using chalk or a water-soluble pen.

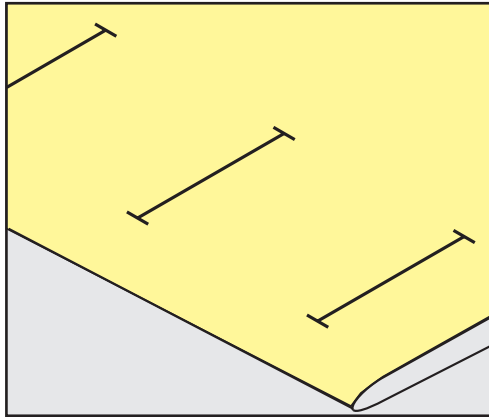

- > For the buttonholes to be sewn automatically, mark the complete length of 1 buttonhole on the fabric using chalk or a water-soluble pen. For any subsequent buttonholes mark the starting point.

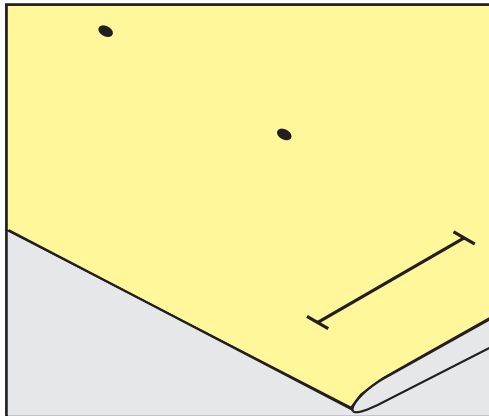

- > For keyhole and round buttonholes mark the length of the bead with chalk or a water-soluble pen on the fabric. For any subsequent buttonholes mark the starting point. The length of the keyhole is sewn additionally.

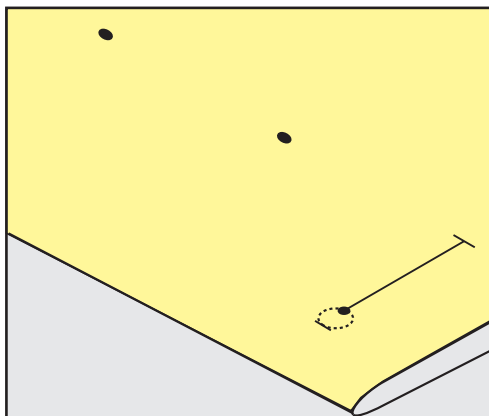

## 8.5 Cord

### Using cord with the Buttonhole foot with slide No. 3A

The cord reinforces and enhances the buttonhole and is particularly suitable for the Buttonhole No. 51. Optimal cord is Perle cotton No. 8, strong hand-sewing thread and fine crochet yarn. It is recommended not to hold the cord when sewing.

Prerequisite:

- The Buttonhole foot with slide No. 3A is attached and raised.
- > Insert the needle at the beginning of the buttonhole.
- > Guide the cord on the right side under the buttonhole foot.
- > Hook the cord over the pin at the back of the buttonhole foot.

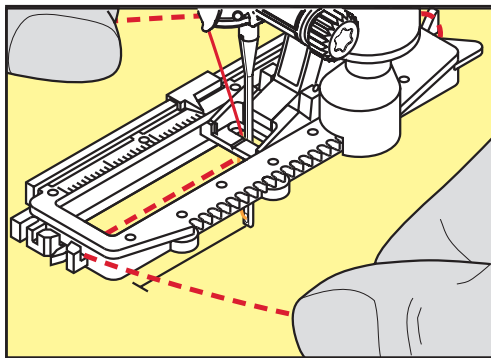

- > Pull the cord on the left side under the buttonhole foot to the front.

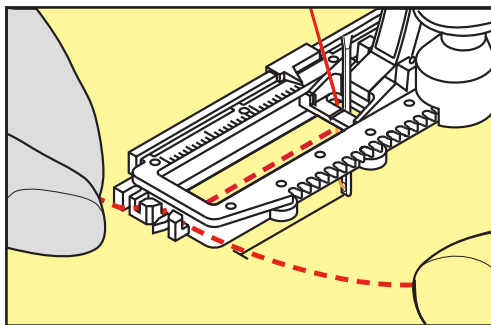

- > Pull the cord ends into the slits.
- > Lower the buttonhole foot.
- > Sew the buttonhole in the usual manner.
- > Pull the cord through the buttonhole until the loop disappears in the bartack.

- > Pull the ends of the cord through to the wrong side of the fabric (using a hand stitching-needle), knot or secure with stitches.

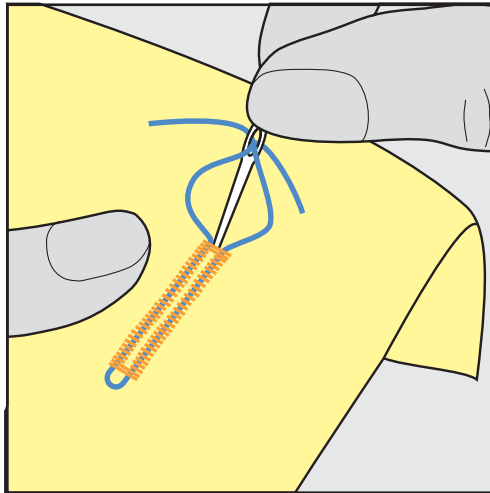

### Using cord with the Buttonhole foot No. 3C (optional accessory)

Prerequisite:

- The Buttonhole foot No. 3C (optional accessory) is attached and raised.
- > Insert the needle at the beginning of the buttonhole.
- > Hook the cord over the pin at the back of the buttonhole foot.

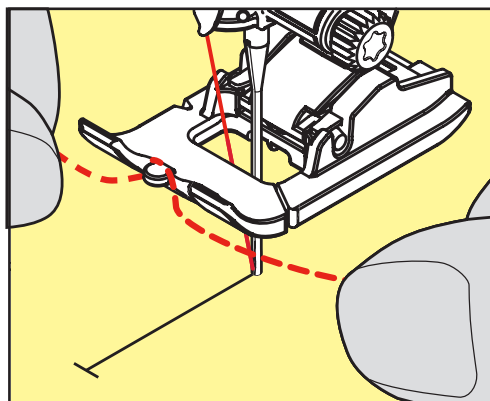

- > Pull both cords ends under the buttonhole foot to the back and place each a cord into a groove of the sole.

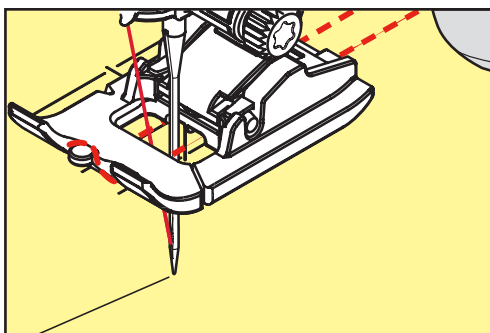

- > Lower the buttonhole foot.
- > Sew the buttonhole in the usual manner.
- > Pull the cord until the loop disappears in the bartack.

- > Pull the ends of the cord with a hand stitching-needle to the wrong side of the fabric and knot or secure.

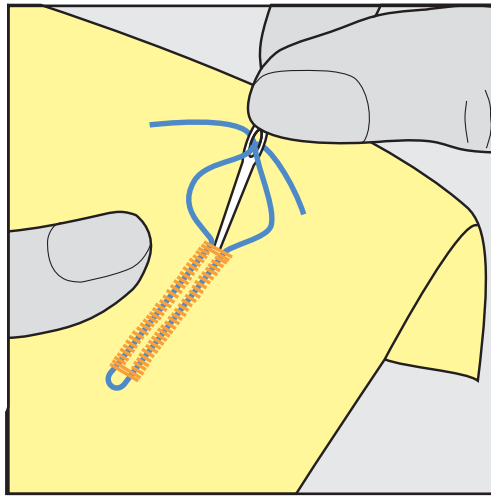

## 8.6 Sewing a test sample

Always sew a test sample of the buttonhole on the same fabric: It is recommended to use the same stabilizer and to select the same buttonhole. The test sample should also be sewn in the respective direction. By sewing a test sample the settings can be adjusted until the sewing result is satisfying.

Alterations of the balance when sewing a manual standard buttonhole as well as the keyhole and the round buttonhole affect both beads in the same way. With the manual keyhole or round buttonhole the alterations affect both sides differently.

If the stitch counter function is used and alterations are made concerning the balance, the alterations affect both buttonhole beads differently.



- > Touch the icon «Buttonholes».
- > Select the buttonhole.
- > Select and attach the desired presser foot.
- > Place the fabric under the presser foot and lower the presser foot.
- > Press the foot control carefully and start sewing. Guide the fabric slightly.
- > Check the balance while sewing and adjust if necessary.
- > Check the test sample and make further amendments if necessary.

## 8.7 Determining the buttonhole slit width

The width of the buttonhole slit can be adjusted between 0.1 – 2.0 mm before sewing.



- > Touch the icon «Buttonholes».
- > Select the buttonhole.



- > «i»-Dialog.

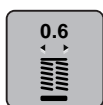

- > Touch the icon «Buttonhole slit width».
- > Turn the «Upper Multifunctional knob» or the «Lower Multifunctional knob» to adjust the buttonhole slit width as desired.
- > Touch the yellow-framed icon to reset the alteration to basic setting.

## 8.8 Determining the buttonhole length



The button can be centered in the yellow circle in the lower portion of the display. The yellow circle can be enlarged or downsized with the «Multifunctional knobs up/down» and the diameter of the button can be determined in this way.

Additionally to the diameter of the button, 2 mm are added automatically for the buttonhole length. If the diameter of the button is 14 mm, the buttonhole length is calculated 16 mm.



- > Touch the icon «Buttonholes».
- > Select the buttonhole.



- > Touch the icon «i»-Dialog.



- > Touch the icon «Adjusting the buttonhole length».
- > Turn the «Upper Multifunctional knob» or the «Lower Multifunctional knob» to adjust the buttonhole length.
- > Touch the yellow-framed icon to reset the alterations to basic setting.

## 8.9 Using the stitch counter function

The stitch counter function is suitable for all types of buttonholes. The left buttonhole bead is sewn forward, the right buttonhole bead is sewn in reverse. If alterations of the balance are made, the stitch counter function has to be saved for every buttonhole separately.

Prerequisite:

- The Buttonhole foot No. 3C (optional accessory) is attached.



- > Touch the icon «Buttonholes».
- > Select the buttonhole.



- > Touch the icon «i»-Dialog.



- > Touch the icon «Stitch counter buttonhole».
- > Sew the desired buttonhole length.
- > Stop the machine.

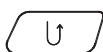

- > Press the button «Quick reverse» so that the machine sews the lower bartack and the second bead in reverse.
- > Stop the machine at the height of the first stitch.
- > Press the button «Quick reverse» again so that the machine sews the upper bartack and the securing stitches.
  - The length of the buttonhole remains saved and every subsequent buttonhole is sewn identically until the machine is switched off.

## 8.10 Sewing a buttonhole automatically

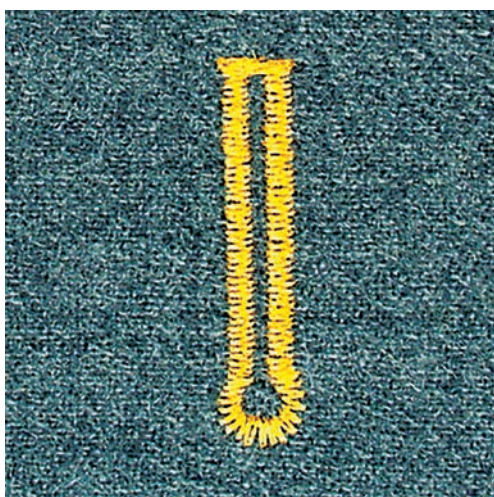
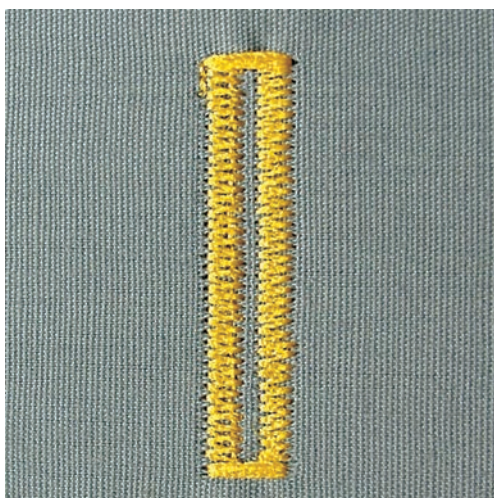

When the Buttonhole foot with slide No. 3A is used, the length of the buttonhole is measured automatically by the lens on the presser foot. The buttonhole will be duplicated and the machine switches to the next step automatically when the maximum length is reached. The Buttonhole foot with slide No. 3A is suitable for buttonholes in the length of 4 – 31 mm, depending on the buttonhole type. The slide of the Buttonhole foot must lie perfectly flat on the fabric so that the length can be measured accurately. All the programmed buttonholes are the same length and of the same nice look.

Prerequisite:

- The Buttonhole foot with slide No. 3A is attached.



- > Touch the icon «Buttonholes».
- > Select the Buttonhole No. 51 – 53 or 54, 56, 57 or No. 64, 65 or 69.
- > Sew the desired buttonhole length.

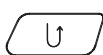

- > Press the button «Quick Reverse» to program the length.
- > Press the button «Start/Stop» or the foot control.
  - The machine finishes the buttonhole automatically. All subsequent buttonholes are sewn at the same length.

## 8.11 Programming the Heirloom buttonhole

Prerequisite:

- The Buttonhole foot with slide No. 3A is attached.



- > Touch the icon «Buttonholes».
- > Select the Buttonhole No. 63.
- > Sew the desired buttonhole length.

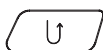

- > Press the button «Quick reverse» to program the length.
  - The machine finishes the buttonhole automatically. All subsequent buttonholes are sewn at the same length.

## 8.12 Sewing the manual 7-step buttonhole

The buttonhole length is determined manually while sewing. The bartack, the keyhole and the securing stitches are pre-programmed. The individual steps can be selected via scrolling with the arrow icons or by pressing the button «Quick Reverse».

Prerequisite:

- The Buttonhole foot No. 3C (optional accessory) is attached.



- > Touch the icon «Buttonholes».
- > Select the buttonhole No. 51.



- > Touch the icon «i»-Dialog.



- > Touch the icon «Adjust the length manually».
  - Step 1 in the display is activated for the buttonhole start.
- > Sew the desired buttonhole length.
  - Step 2 is activated.



- > Stop at the desired length of the buttonhole or at the marking.
- > Touch the icon «Scrolling down» so that step 3 appears.
- > Stop at the height of the first stitch at the buttonhole start.
- > Touch the icon «Scrolling down» so that step 4 appears.
  - The machine sews the upper bartack and stops automatically.
- > Touch the icon «Scrolling down» so that step 5 appears.
  - The machine sews the second bead.

- > The machine stops at the height of the last stitch of the first bead.
- > Touch the icon «Scrolling down» do that step 6 appears.
  - The machine sews the lower bartack and stops automatically.
- > Touch the icon «Scrolling down» so that step 7 appears.
  - The machine stops and secures automatically.

### 8.13 Sewing the manual 5-step buttonhole

The length of the beads is manually determined when sewing. Bartack, eye and securing stitches are preprogrammed. The individual steps can also be selected by scrolling via the arrow icons, by direct selection or by touching the button Quick reverse.

Prerequisite:

- The Buttonhole foot No. 3C (optional accessory) is attached.



- > Touch the icon «Buttonholes».
- > Select the buttonhole No. 56.



- > Touch the icon «i»-Dialog.



- > Touch the icon «Adjusting the length manually».
  - Step 1 in the display is activated the buttonhole start.
- > Sew the desired buttonhole length.
  - Step 2 is activated.



- > Stop at the desired length of the bead or at the marking.
- > Touch the icon «Scrolling down» so that step 3 appears.
- > The machine sews the keyhole or the eye and stops automatically.
- > Touch the icon «Scrolling down» so that step 4 appears.
  - The machine sews the second bead in reverse.
- > Stop the machine at the height of the first stitch at the buttonhole start.
- > Touch the icon «Scrolling down» so that step 5 appears.
  - The machine sews the upper bartack and secures automatically.



### 8.14 Cutting the buttonhole open with the seam ripper

- > Place a pin in each end of the buttonhole to avoid accidental cutting into ends of buttonhole.
- > Cut the buttonhole from both ends to the middle.

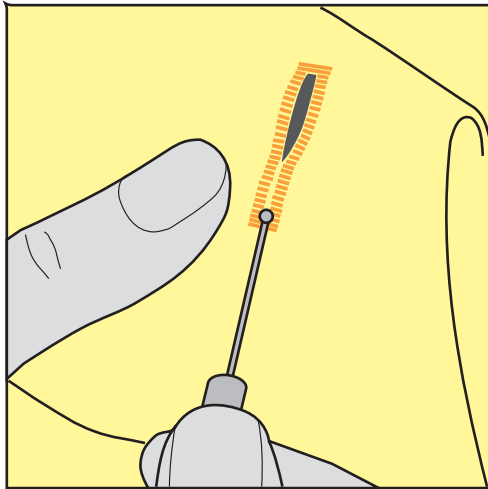

### 8.15 Cutting open buttonholes with the buttonhole cutter (optional accessory)

- > Place the fabric on an appropriate wood.

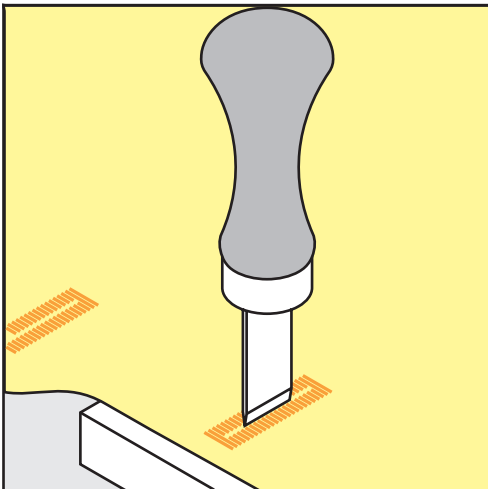

- > Position the cutter in the center of the buttonhole.
- > Press down on the cutter with your hand.

### 8.16 Sewing on buttons

With the Button sew-on Program buttons with 2 or 4 holes can be sewn on. To reinforce the stability the Button sew-on Program can be sewn twice. When sewing on a button with 4 holes, the front holes should be sewn first.

Buttons sewn on for decorative purposes only are stitched without a thread shank. The shank height is the distance between the button and the fabric. When using the Button sew-on foot No. 18 (optional accessory), the shank height can be adjusted with the screw.

With the Button sew-on Program the first securing stitch is always stitched into the left hole of the button.

Prerequisite:

- The Darning foot No. 9 (optional accessory) or the Button sew-on foot No. 18 (optional accessory) is attached.
- > Lower the feed dog.
- > Select the Button sew-on Program No. 60.
- > Place the button on the sewing project.
- > Turn the handwheel to adjust the distance between the holes.
- > Hold the threads when starting to sew and, if necessary, alter the stitch width.
  - The machine sews the Button sew-on Program and stops automatically.
- > Pull on both bobbin threads until the ends of the upper threads are visible on the wrong side.
- > Knot the ends manually.

## 8.17 Sewing eyelets















For increased stability sew the eyelet twice.

Prerequisite:

- The Reverse pattern foot No. 1C or the Open embroidery foot No. 20C is attached.
- > Select the Eyelet Program No. 61 or No. 62.
- > Turn the «Upper Multifunctional knob» or the «Lower Multifunctional knob» to alter the size of the eyelet.
- > Sew the Eyelet Program.
  - The machine stops automatically at the end of the Eyelet Program.
- > Use an awl, punch pliers or a hole punch to open the eyelet.

## 9 Quilting

### 9.1 Overview Quilt Stitches

Stitch patterns	Stitch number	Name	Description
	1324	Quilting, Securing Program	To secure at the sewing start and sewing end with short stitches forward.
	1325	Quilting straight stitch	Straight stitch with 3 mm stitch length to sew pieces of patchwork.
	1326	Piecing stitch/Straight stitch	Shorter straight stitch with 2 mm stitch length.
	1327	Stippling stitch	Imitation of stipple quilting.
	1328	Handlook quilt stitch	Imitation of handlook quilt stitch with monofilament.
	1329	Blanket stitch	For appliqué and sewing on ribbons.
	1330	Double blanket stitch	For appliqué and sewing on ribbons.
	1331	Blindstitch narrow	To sew blind stitches.
	1332	Feather stitch	For "Crazy Patchwork" and embellishing.
	1333	Feather stitch variations 1333 – 1338	For "Crazy Patchwork" and embellishing.
	1339	Decorative Quilt stitch variations 1339 – 1345, 1351, 1355 – 1370, 1388-1390, 1393	For "Crazy Patchwork" and embellishing.
	1346	Quilt stitch/Handlook stitch variations 1346, 1347, 1348, 1350	Imitation of stipple quilting, to use with monofilament.
	1352	Blanket stitch dual	To edgestitch between two appliqués, "Crazy Patchwork".
	1353	Double blanket stitch dual	To edgestitch between two appliqués, "Crazy Patchwork".

Stitch patterns	Stitch number	Name	Description
	1354	Satin stitch	For appliqué.

## 9.2 Sewing in the Quilting securing Program

Prerequisite:

- The Reverse pattern foot No. 1C/1D is attached.
- > Select Quilt stitch pattern No. 1324.
- > Press the foot control.
  - The machine sews 6 stitches forward automatically when sewing is started.
- > Sew the seam at the desired length.
- > Press the button «Quick reverse».
  - The machine sews 6 stitches forward automatically and stops automatically at the end of the Securing Program.

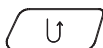

## 9.3 Sewing handlook quilt stitches

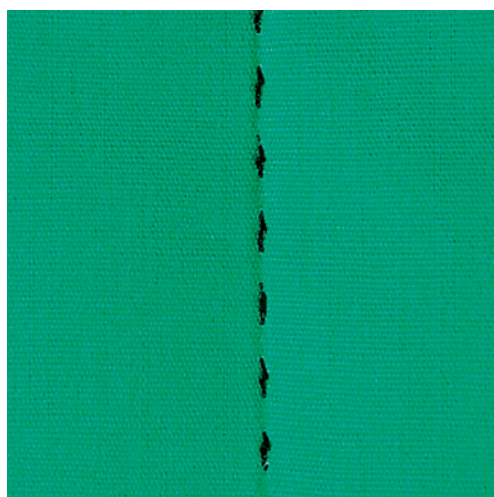

Handlook quilt stitches are suitable for all fabrics and sewing projects which should look «hand sewn». It is recommended to use a monofilament thread as upper thread and an embroidery thread as bobbin thread. The sewing speed should be moderate to prevent the monofilament from breaking. If required, the upper thread tension and the balance can be adjusted to the sewing project and the desired quilt stitch.

Prerequisite:

- The Reverse pattern foot No.1C is attached.
- > Touch the icon «Quilt stitches».
- > Select the Handlook quilt stitch No. 1328 or 1346, 1347 or 1348 or 1350.
- > If required, adjust the upper thread tension and the balance to the sewing project and the desired quilt stitch.
- > Press the foot control or the button «Start/Stop» to start the machine.



## 9.4 Guiding the quilt work freely



Quilt gloves with rubber fingertips (optional accessory) will help when guiding the fabric.

It is recommended to use the slide-on table and the Free Hand System. With free-motion quilting, it is of advantage to quilt from the center outwards and to guide the fabric using smooth, round movements to form the design of your choice. Free-motion quilting and darning are based on the same free-motion principles.

With stipple quilting, entire surfaces of the fabric are filled with quilt stitches. The single lines of stitching are rounded and never cross one another.

Prerequisite:

- The top layer, the batting and the backing are pinned together or basted.
- The feed dog is lowered.
- The Darning foot No. 9 (optional accessory) is attached.



- > Touch the icon «Practical stitches».
  - The Straight stitch No. 1 is selected automatically.
- > Adjust the upper thread tension and the balance to the sewing project if necessary.
- > Press the foot control or the button «Start/Stop» to start the machine.
- > Hold both hands close to the presser foot like an embroidery hoop to guide the fabric.
- > If the thread is lying on top of the fabric, slow down the movement.
- > If there are knots on the wrong side of the fabric, move the fabric more quickly.

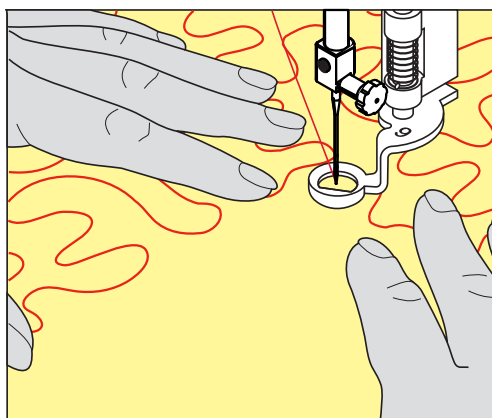

## 10 BERNINA Stitch Regulator (BSR)

The BERNINA Stitch regulator equalizes the stitch length which results of the free movement of the fabric while free-motion sewing - a sewing technique which grows more and more popular. When free-motion sewing with the BSR presser foot, every stitch is equally long and the stitch formation is perfectly regular.

As soon as the BSR presser foot is attached and the feed dog is lowered, the selection menu of the desired mode appears in the display of the machine. The BSR presser foot can be used with sewing straight stitch as well as zig zag.

The BSR presser foot reacts on the movement of the fabric and therefore controls the speed of the machine up to the highest possible speed. It can be said: The faster the movement of the material, the higher the speed of the machine.

If the fabric is moved too quickly, an acoustic signal sounds. The beeper can be activated or deactivated in the «BSR» display. The sound of the beeper can also be activated or deactivated in the Setup Program (see page 58).

### 10.1 Using the BSR mode

The BSR function can be controlled via the foot control or the button «Start/Stop».

Starting via the foot control: The foot control needs to be pressed while quilting. The machine keeps running in the BSR1 mode until the foot control is released, even if the fabric isn't moved.

If quilting is stopped in the BSR2 mode, the machine sews another stitch depending on the needle position and stops with needle position up.

Prerequisite:

- The slide-on table is attached.
- The Free Hand System lever is attached.

> Lower the feed dog.

> Select the desired BSR mode.

> Push the button «Start/Stop» or press the foot control to lower the presser foot.

> Push the button «Start/Stop» again or press the foot control again and keep pressed to start the BSR mode.

– At the BSR presser foot a red light is on.

> Move the fabric to control the speed of the machine in the BSR mode.

> Push the button «Start/Stop» again or release the foot control to stop the BSR mode.

– The BSR mode stops and the red light at the presser foot goes off.

> Touch the icon «BSR» (1) to deactivate the BSR mode and to quilt without automatic stitch length.



## 10.2 BSR mode 1

The BSR function can be controlled via the foot control or with the button «Start/Stop». Start the BSR mode. At the BSR presser foot a red light is on. By moving the fabric the machine accelerates. If the fabric isn't moved, securing in place is possible without pressing an additional button. When working via the foot control or when using the button «Start/Stop», the BSR mode doesn't stop automatically.

## 10.3 BSR mode 2

The BSR function can be controlled via the foot control or the button «Start/Stop». The machine starts only when the foot control or the button «Start/Stop» is pressed and the fabric is moved simultaneously. Without moving the fabric, the BSR2 modus stops after about 7 seconds. The red light goes off (only when working with the button «Start/Stop»). When working via the foot control, the red light doesn't go off.

## 10.4 BSR function with Straight stitch No. 1

This function allows free-motion quilting with straight stitch and a pre-programmed stitch length up to 4 mm. The programmed stitch length is maintained within a certain speed, independent of the fabric movement.

## 10.5 BSR function with Zig zag No. 2

The zig zag can be used e.g. for thread painting. The set stitch length will not be maintained when sewing the zig zag stitch, but the BSR function simplifies the application.

## 10.6 Sewing preparation

### Attach the BSR presser foot

NOTICE The lens of the BSR presser foot is dirty

The machine doesn't recognize the BSR presser foot.

> Clean the lens with a soft, slightly damp cloth.

- > Raise the presser foot.
- > Raise the needle.
- > Switch the machine off and disconnect it from the power supply system.
- > Push the clamping lever up.



- > Remove the presser foot.
- > Insert the BSR presser foot upwards over the cone.
- > Press the clamping lever down.

- > Insert the cable of the BSR presser foot into the connection (1).

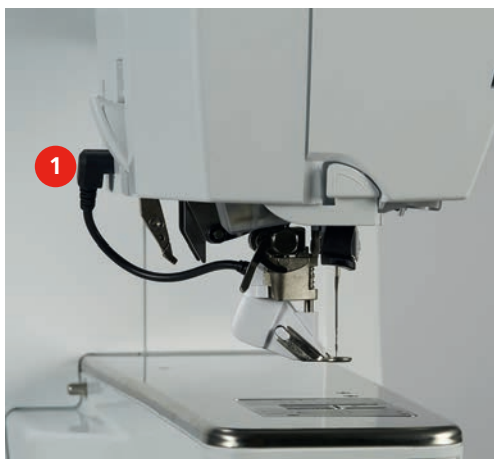

- > Switch the machine on.
  - The BSR display opens and the BSR 1 mode is activated.

### Changing the presser foot sole

NOTICE The lens of the BSR presser foot is dirty.

The machine doesn't recognize the BSR presser foot.

- > Clean the lens with a soft, slightly damp cloth.

The basic stitch length is 2 mm. When sewing small shapes and stippling it is recommended to shorten the stitch length to 1 – 1.5 mm.

- > Raise the needle.
- > Raise the presser foot.
- > Switch the machine off and disconnect it from the power supply system.
- > Remove the presser foot (see page 36).
- > Press both push buttons at the BSR foot against each other.

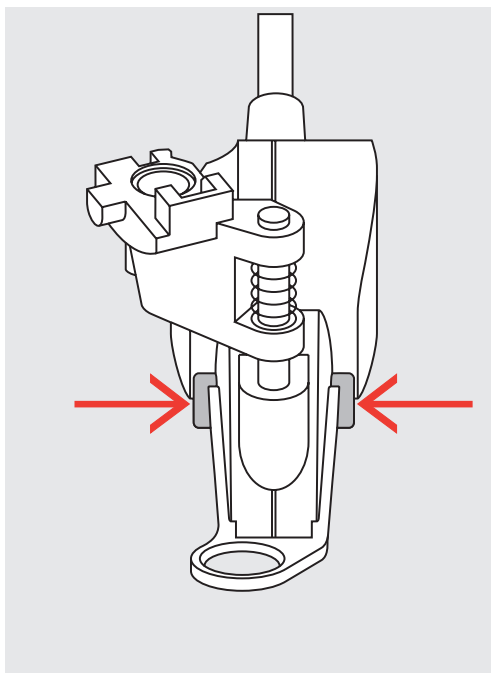



- > Pull the presser foot sole out of the guide downwards.
- > Insert the new presser foot sole into the guide and push upwards until it clicks into place.
- > Attach the BSR presser foot (see page 121).

## 10.7 Securing

### Securing in BSR1 mode with the button «Start/Stop»

Prerequisite:

- The BSR presser foot is attached and connected with the machine.
- The BSR display is opened and the BSR1 mode is activated.

- > Lower the feed dog.
- > Lower the presser foot.
- > Press the button «Needle up/down» twice.
  - The bobbin thread is brought up.
- > Hold the upper and the bobbin thread.



- > Press the button «Start/Stop».
  - Start the BSR mode.
- > Sew 5 – 6 securing stitches.



- > Press the button «Start/Stop».
  - The BSR mode stops.
- > Cut the thread.

### Securing in BSR2 mode

Prerequisite:

- BSR presser foot is attached and connected with the machine.
- The BSR display is open and the BSR2 mode is activated.

- > Lower the presser foot.
- > Press the button «Securing».
- > Press the foot control or the button «Start/Stop».



By moving the fabric some short securing stitches are sewn, then the programmed stitch length is activated and the securing function is deactivated automatically.

## 11 Embroidery

### 11.1 Overview Embroidery module



- |   |   |   |                             |
|---|---|---|-----------------------------|
| 1 | Embroidery arm                            | 3 | Guide rails for the machine |
| 2 | Bracket for attaching the embroidery hoop | 4 | Connection to the machine   |

### 11.2 Supplied accessories



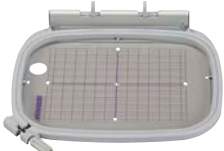





Illustration	Name	Purpose
	Embroidery foot No. 26	For embroidering, darning and free-motion quilting.
	Embroidery hoop oval, 145 x 255 mm with embroidery template, VAR 00	To embroider large embroidery motifs.  The embroidery template serves the purpose to calibrate the embroidery hoop and to place the fabric exactly.
	Embroidery hoop medium, 100 x 130 mm with embroidery template	To embroider medium-sized embroidery motifs.  The embroidery template serves the purpose to calibrate the embroidery hoop and to place the fabric exactly.

Illustration	Name	Purpose
	Embroidery hoop small, 72 x 50 mm with embroidery template	To embroider small embroidery motifs. The embroidery template serves the purpose to place the fabric exactly.
	USB Connecting cable	The USB connecting cable serves the purpose to transfer data. When the embroidery software (optional accessory) is installed on the computer, embroidery motifs can be transferred from the computer to the machine.
	Embroidery needle assortment SUK	Various needle sizes for embroidery.
	Template holder	The template holders serve as a help when placing and removing the template in and from the embroidery hoop.
	Net for thread spool, white	The spool net provides an even unwinding of the thread when using slippery embroidery threads.

## 11.3 Important Embroidery information

### Choosing the embroidery motif

Simple motifs with a low stitch count are suitable for embroidery on fine material. Densely embroidered motifs (e.g. with multiple color and embroidery direction changes) are suitable for medium and heavy weight material.

### Embroidery test

For the embroidery test, always use the original material reinforced with the same stabilizer as will be used later. For this embroidery test it is recommended to use the same colors, threads and needles which are planned to be used for the embroidery project.

### The size of the embroidery motif

Embroidery motifs can be scaled/sized on the embroidery machine or on the PC with the BERNINA embroidery software (optional accessory). Increasing/decreasing in a range of +/- 20 % provides the best results.

## Underlay stitches

Underlay stitches are the foundation of a motif and are used to stabilize the base material and hold it in shape. They also prevent the covering stitches of the motif from sinking into the knit or the nap of the material.

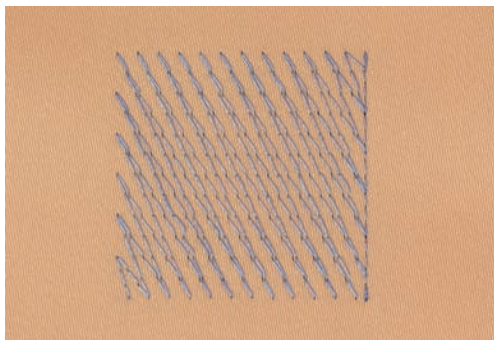

## Satin stitch

The needle moves left to right and vice versa. The result is a very dense, covering zig zag stitching to fill the shape. Satin stitching fills are ideal for narrow and small shapes. Satin stitching is, however, not suitable for larger areas, since wide stitches are too loose and do not cover the fabric properly. In addition there is the risk that with too long stitches the threads could catch on something which would damage the embroidery.

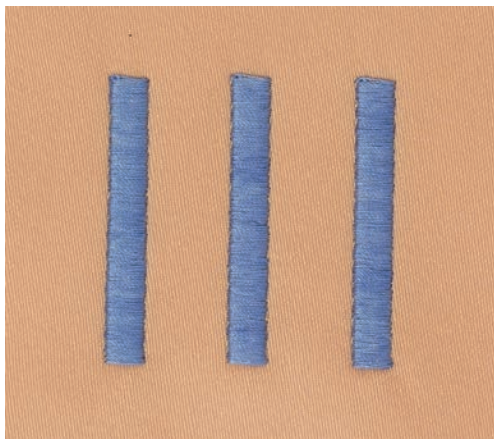

## Step stitch

Many short, equally long stitches are embroidered in offset rows closely next to each other which results in a densely filled area.

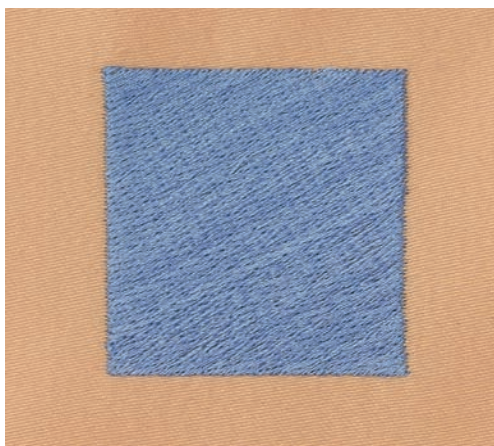

## Connecting stitches

Long stitches which are used to get from one part of the motif to the next. Before and after the connecting stitch securing stitches are sewn. Connecting stitches are trimmed.

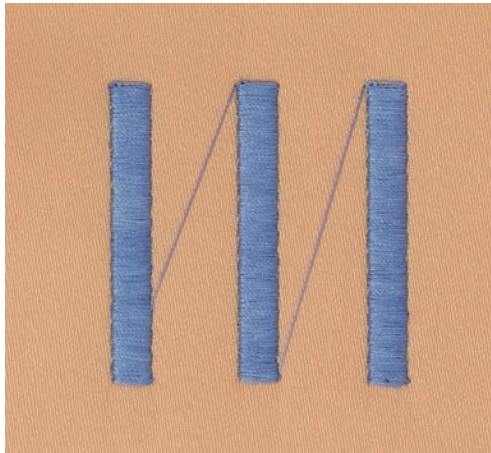

## Upper thread

A good quality thread (brand manufacturer) is essential for embroidery so that the embroidery is not affected negatively because of poor thread or thread breakage.

Embroidery is particularly effective if you use 40wt glossy rayon or polyester embroidery threads as upper threads. They are available in a wide range of colors for beautiful embroidery.

- Polyester with a brilliant sheen is a hard wearing, colorfast thread and has a high tensile strength which is suitable for all types of embroidery.
- Rayon is a soft viscose fiber with a brilliant sheen and suitable for fine, delicate embroidery, or items that will not receive excessive wear and tear.
- Metallic thread is a light to medium weight thread suitable for special effects in embroidery.
- When using metallic threads, the speed and the upper thread tension should be reduced.



## Bobbin thread

In most cases black or white bobbin thread is used for embroidering. When both sides should have the same look, it is recommended to use the same color for bobbin and upper thread.

- Bobbin Fill is an especially soft and light polyester thread which is suited to be used as bobbin thread.
- This special bobbin thread ensures a steady thread tension and an optimal intertwining of the upper and bobbin thread.

- Fine mercerized cotton thread which is suitable for embroidery on cotton.



### Tear-away stabilizers

Using a stabilizer ensures more stability of the embroidery project. A tear-away stabilizer suits all woven and non-stretch materials. 1 – 2 layers can be used. Stabilizers are available in different weights. With larger embroidered areas the stabilizer will remain under the thread. The stabilizer is applied to the wrong side of the fabric with temporary adhesive spray before hooping. Carefully tear away excess stabilizer from the back of the embroidery after stitching.

### Cut-away stabilizers

Using a stabilizer ensure more stability of the embroidery project. A cut-away stabilizer is recommended for fabrics with stretch. 1 – 2 layers can be used. Stabilizers are available in different weights. With larger embroidered areas the stabilizer will remain under the thread. The stabilizer is applied to the wrong side of the fabric with temporary adhesive spray before hooping. Carefully cut away excess stabilizer from the back of the embroidery after stitching.

## 11.4 Overview Embroidery functions



- |   |   |    |                                |
|---|---|----|--------------------------------|
| 1 | Upper thread tension                              | 6  | Filling level of bobbin thread |
| 2 | Presser foot display/Presser foot selection       | 7  | Selection                      |
| 3 | Embroidery hoop selection/Embroidery hoop display | 8  | Editing                        |
| 4 | Stitch plate/Needle selection                     | 9  | Colors                         |
| 5 | Feed dog up/down                                  | 10 | Embroidery                     |



## 11.5 Embroidering preparation

### Attaching the Embroidery foot No. 26

- > Raise the needle.
- > Raise the presser foot.
- > Switch the machine off and disconnect it from the power supply system.
- > Push the clamping lever up.



- > Remove the presser foot.
- > Guide the Embroidery foot No. 26 upwards over the cone.
- > Press the clamping lever down.

### Selecting the Embroidery foot No. 26

After having attached the Embroidery foot No. 26, it can be selected and saved on the machine. Moreover optional presser feet can be displayed which are available for the currently selected embroidery motif.

- > Switch the machine on.
- > Select an embroidery motif.
- > Touch the icon «Presser foot display/Presser foot selection».
- > Select the Embroidery foot No. 26.



### Inserting the embroidery needle



Embroidery needles of the type 130/705 H-SUK provide a larger eye and are slightly rounded. This avoids thread abrasion when using Rayon- and cotton embroidery thread. Depending on the embroidery thread use a size No. 70-SUK to No. 90-SUK needle.

- > Raise the needle.
- > Switch the machine off and disconnect it from the power supply system.
- > Remove the presser foot.

- > Loosen the fixing screw using the grey Torx screwdriver.



- > Pull the needle down.
- > Hold the needle with the flat side to the back.
- > Insert the needle as far as it will go.
- > Tighten the needle clamp using the grey Torx screwdriver.

### Selecting the needle

After having changed the needle, it can be checked whether or not it is suitable to be used together with the selected stitch plate.



- > Touch the icon «Needle/Stitch plate selection».
- > Select the attached needle.



- If the selected needle is suitable in combination with the stitch plate, sewing can be started.
- If the selected needle is not suitable in combination with the stitch plate, starting the machine is automatically prevented.

### Selecting the needle type and the needle size

Convenient memory function: To prevent a loss of information, the needle type and the needle size can be saved additionally on the machine. The saved needle type and the saved needle size can be checked at any time.



- > Touch the icon «Stitch plate/Needle selection».





- > Touch the icon «Needle type/Needle size».
- > Select the needle type (1) of the inserted needle.
- > Select the needle size (2) of the inserted needle.



### Attaching the stitch plate CutWork/Straight

The stitch plate CutWork/Straight has a small needle hole in the needle insertion area. The small needle hole supports the fabric. This optimizes the stitching results.

- > Lower the feed dog (1).



- > Switch the machine off and disconnect it from the power supply system.
- > Remove the needle.
- > Remove the presser foot.
- > Press the stitch plate down at the mark back right until it flips up.



- > Remove the stitch plate.
- > Place the openings of the stitch plate CutWork/Straight above the corresponding guide pins and press down until it clicks into place.

## Selecting the stitch plate CutWork/Straight

After having changed the stitch plate, it can be checked whether or not it is suitable to be used together with the selected needle.



- > Touch the icon «Stitch plate/Needle selection».
- > Select the stitch plate CutWork/Straight.



## Attaching the Module

### NOTICE Transporting the embroidery module

Damage to the embroidery module connection and machine.

- > Remove the embroidery module before transporting the machine.

Prerequisite:

- The slide-on table must not be attached.
- > Make sure that the module and the machine are placed on a stable, even surface.
- > Make sure that there is enough space around to allow the unimpeded movement of the embroidery arm.
- > Lift the embroidery module on the left.
- > Carefully slide the module from left to right into the module connection of the machine.

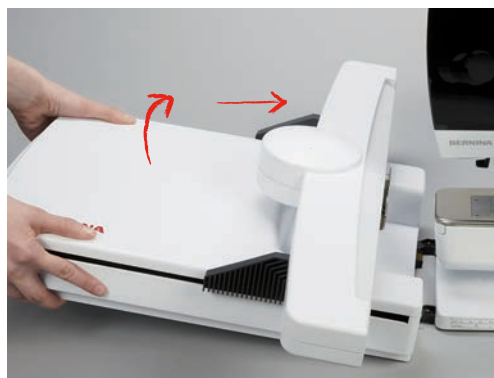

- > To remove, lift the embroidery module on the left and carefully pull to the left.

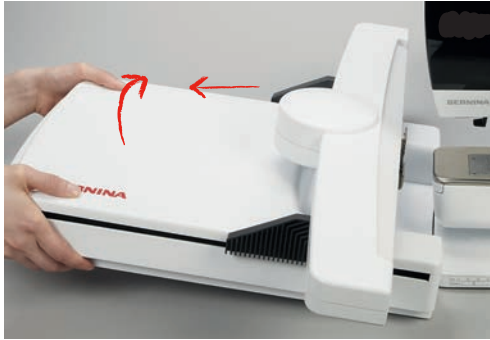

### Preparing the embroidery hoop

The embroidery hoop consists of an outer and an inner hoop. There is a corresponding template for every hoop. The embroidery area is marked in 1 cm squares. The center and end point are marked with holes. The required marks can be transferred to the material.

- > Mark the center of an embroidery motif on the fabric, using a water-soluble pen.

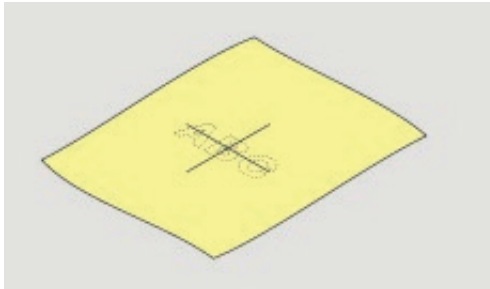

- > Loosen the screw on the outer hoop.
- > Remove the inner hoop.
- > Make sure that the arrows marks of both hoops match.
- > Attach the template holder.
- > Place the template in the inner hoop, so the BERNINA logo is at the front edge at the arrow mark until it clicks into place.

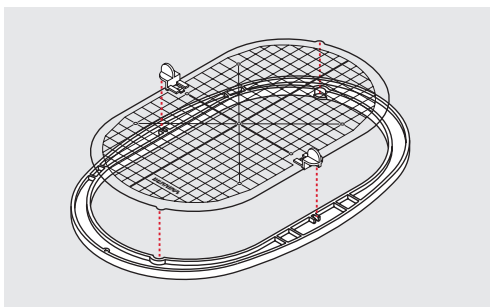

- > Place the material under the inner hoop.
- > Line up the marked center point on the center of the template.

- > Place the material and the inner hoop on the outer hoop so that the arrows of both hoops match.

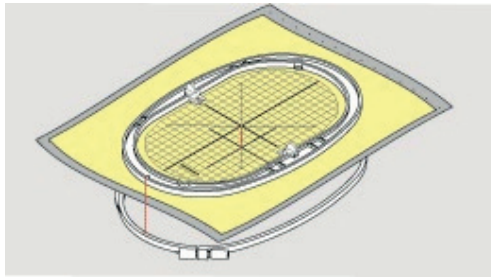

- > Fit the hoops into each other; ensure that the material does not move.
- > Hoop the fabric to be embroidered tightly.
- > Tighten the screw.
- > Remove the template from the hoop by using the template holder.

### Using adhesive spray

The application of adhesive spray is recommended for stretch and smooth materials and knitware. It prevents the fabric from losing shape and slipping. Appliqués can be exactly positioned. The adhesive spray shouldn't be used near your machine to avoid contamination.

- > Use the adhesive spray carefully at a distance 25 – 30 cm when spraying the stabilizer.
- > Adhere the sprayed stabilizer to the wrong side of the fabric carefully, smoothing material so there are no puckers.
- > Position smaller parts such as pocket flaps or collars on the stabilizer.
- > To avoid the possibility of getting hoop marks when working with napped materials or fleece, don't hoop the parts but spray the stabilizer and hoop it.
- > Adhere the fabric to be embroidered.

### Using spray starch

Spray starch is ideal for additional stiffening fine, soft or loosely woven materials. Always use an additional stabilizer on the wrong side of the material.

- > Spray the area to be embroidered.
- > Let it dry or press gently with a warm iron if necessary.

### Using iron-on interfacing

Iron-on interfacings are available in a variety of weights. It is recommended to use an iron-on interfacing which is easily removable from the material. Iron-on interfacings suit all materials that are easily distorted like stretch fabric such as tricot and jersey.

- > Iron-on interfacings are ironed to the wrong side of the material using a warm iron.

### Using paper-backed adhesive stabilizer

Paper-backed adhesive stabilizers are intended to be used for fabrics such as jersey and silk as well as for embroidery projects which are not suited to be hooped in the embroidery hoop.

- > Place the stabilizer in the hoop, so that the paper side is up.
- > Use a pair of scissors to score the paper and remove paper in the hoop area.
- > Position the fabric to be embroidered on the stabilizer and press it on place.
- > Remove any adhesive residue before starting the machine.

## Using water-soluble stabilizer



For lace embroidery it is recommended to hoop 1 - 3 layers of water-soluble stabilizer in the embroidery hoop. As the embroidery motif is not embroidered on the fabric, only the thread embroidered motif is left. The embroidery motifs should be combined with short stitches otherwise the individual motifs may fall out.

The stabilizer dissolves in water. Water-soluble stabilizers are an ideal protection for looped pile fabrics preventing the loops from being damaged! It prevents threads from sinking into the material and keeps the fabric pile from poking through the embroidery. Water-soluble stabilizers are ideal for fine, sheer fabrics where other stabilizers may show through the embroidery stitches as well as for lace embroidery.

- > Place the stabilizer on top of the material.
- > Place all the layers together into the embroidery hoop.
- > Use adhesive spray to adhere stabilizer if necessary.
- > For material with a pile, reinforce with additional, suitable stabilizer on the wrong side.
- > After dissolving, lay the motif down flat and let dry.

## Attaching the hoop

- > Raise the needle.
- > Raise the Embroidery foot.
- > Hold the hoop with the right side of the fabric up with the attaching mechanism to the left.
- > Position the hoop under the Embroidery foot.
- > Press both attaching mechanisms (1) of the hoop towards each other.
- > Position the center points (2) of the hoop over the bracket of the embroidery arm.
- > Press the hoop down until it clicks in position.
- > Release the attaching mechanism (1).

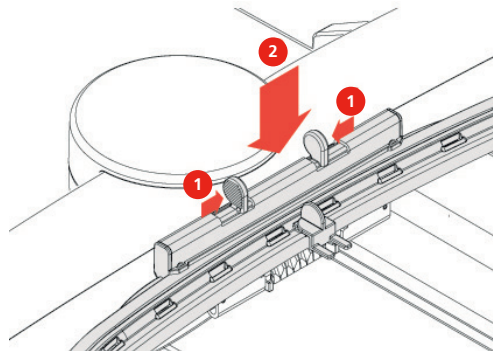

- > Press the attaching mechanisms of the hoop towards each other to remove the hoop.
- > Remove the hoop.

## 11.6 Selecting an embroidery motif

All BERNINA embroidery motifs can either be embroidered as-is or changed using the various functions offered by the embroidery machine. All embroidery motifs can be found in the attachment (see page 168). In addition to that, embroidery motifs from the personal memory or from the BERNINA USB stick (optional accessory) can be loaded.

- > Lower the feed dog (1).



- > Attach the stitch plate CutWork/Straight (see page 131).
- > Insert the needle (see page 129).
- > Attach the Embroidery foot No. 26 (see page 129).
- > Touch the icon «Home».



- > Touch the icon «Embroidery mode».
- > Select an alphabet, embroidery motif, stitch pattern or a personal embroidery motif from one of the files.

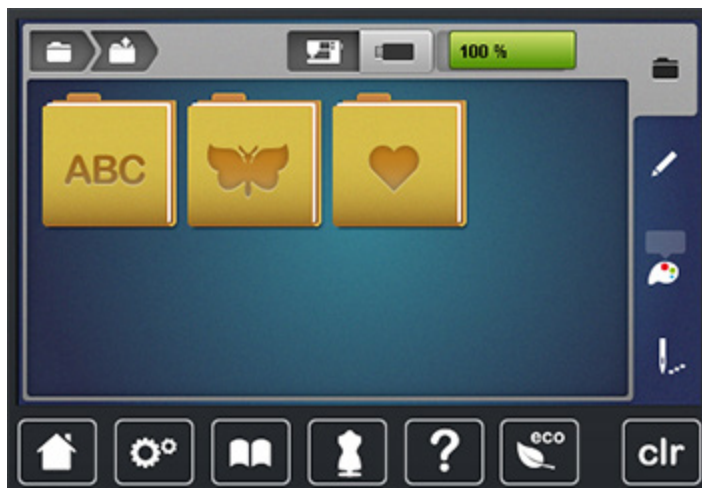

## 11.7 Embroidery hoop

### Overview Embroidery hoop selection



- |   |                                       |   |                |
|---|---------------------------------------|---|----------------|
| 1 | Moving the hoop to the left           | 4 | Grid           |
| 2 | Moving the hoop to the back           | 5 | Motif center   |
| 3 | Moving the module for the sewing mode | 6 | Hoop selection |

### Changing the upper thread in the embroidery mode

Relocating the embroidery hoop facilitates threading when the needle is close to the embroidery hoop.



- > Touch the icon «Embroidery hoop display/Embroidery hoop selection».



- > Touch the icon «Moving the embroidery hoop to the left».
- > Thread the upper thread (see page 41).



- > Push the button «Start/Stop» to move the embroidery hoop back to the last position.

### Changing the bobbin thread in Embroidery mode

To facilitate changing the bobbin, it is recommended to move the hoop to the back before threading. This makes it easier to open the bobbin cover.



- > Touch the icon «Hoop display/Hoop selection».



- > Touch the icon «Moving the hoop to the back».
- > Thread the bobbin thread (see page 46).



- > Push the button «Start/Stop» to move the hoop back to its previous position.

## Sewing with connected embroidery module

The embroidery module can be positioned so that any sewing projects can be carried out even if the module is connected.



- > Touch the icon «Hoop display/Hoop selection».
- > Remove the hoop.



- > Touch the icon «Moving the module for sewing mode».



- > Touch the icon «Home».



- > Touch the icon «Sewing mode».

## Activating the grid

When the center of the hoop and the grid are displayed, the embroidery motif can be positioned more exactly.



- > Touch the icon «Hoop display/Hoop selection».

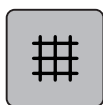

- > Touch the icon «Grid on/off» to display the center of the hoop on the display.
- > Touch the icon «Grid on/off» again to display the grid.
- > Touch the icon «Grid on/off» again so that the center of the hoop and the grid disappear.

## Locating the center of the embroidery motif



- > Touch the icon «Hoop display/Hoop selection».



- > Touch the icon «Center of the embroidery motif» to position the hoop so that the needle is placed exactly over the center of the embroidery motif.
- > Touch the icon «Center of the embroidery motif» again to position the hoop so that the needle is placed exactly over the motif start.

## Relocating the hoop

The hoop is moved automatically to a new position when the embroidery motif is repositioned. That's why the icon «Virtual positioning» is automatically activated and outlined in yellow, as soon as the hoop is attached. If no hoop is attached, the icon «Virtual positioning» cannot be selected.

Prerequisite:

- The hoop is attached.



- > Touch the icon «Hoop display/Hoop selection».



- > Touch the icon «Virtual positioning» to deactivate the automatic movement of the hoop when having repositioned the embroidery motif.



- > Touch the icon «Virtual positioning» again to activate the automatic movement of the hoop when having repositioned the embroidery motif.

## 11.8 Editing the embroidery motif

### Overview Editing embroidery motif



- |   |  |   |   |
|---|--|---|---|
| 1 | Zoom in                                      | 6 | Rotating the embroidery motif           |
| 2 | Relocating the embroidery motif              | 7 | Deleting the embroidery motif           |
| 3 | Mirror image left/right                      | 8 | Altering the stitch type/stitch density |
| 4 | Altering the embroidery motif proportionally | 9 | Checking motif size                     |
| 5 | Mirror image down/up                         |   |   |

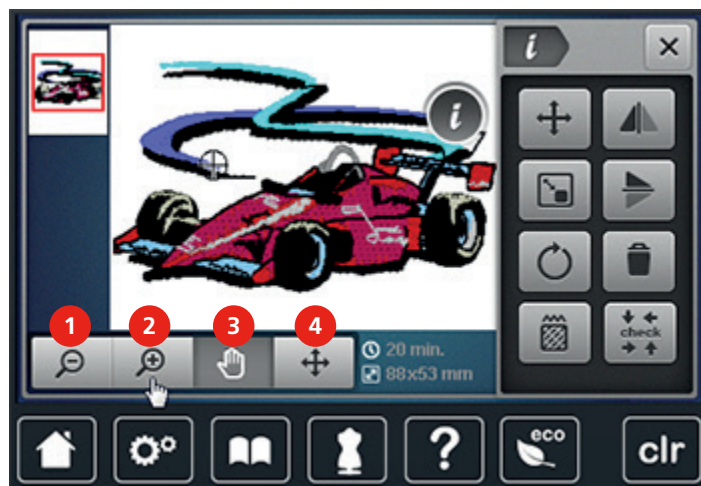

- |   |          |   |                              |
|---|----------|---|------------------------------|
| 1 | Zoom out | 3 | Relocating the view          |
| 2 | Zoom in  | 4 | Moving the view of the motif |

## Monitoring the embroidery time

In the display «Editing» at lower left (1), the estimated embroidery time is indicated in minutes and the width and height of the embroidery motif is indicated in millimeters.



## Adjusting the upper thread tension

The basic setting of the upper thread tension is set automatically as soon as a stitch pattern or an embroidery motif is selected.

The upper thread tension is set optimally at the BERNINA factory and the machine has been tested. Metrosene-/Seralon thread size 100/2 (Company Mettler, Switzerland) is used for upper and bobbin thread.

When of using other types of sewing or embroidery threads, the optimal tension may vary. Therefore it may be necessary to adjust the upper thread tension according to the sewing or embroidering project as well as the desired stitch pattern or the embroidery motif individually.

The higher the upper thread tension, the tighter the upper thread which means that the bobbin thread is pulled up to the top of the fabric. When the upper thread tension is low, the upper thread is less tightened which means that the bobbin thread is pulled up less.

Alterations of the upper thread tension in the Setup Program affect the currently selected stitch or embroidery patterns. Permanent alterations of the upper thread tension for the sewing mode (see page 50) and for embroidery mode (see page 54) can be made in the Setup Program.







- > Touch the icon «Upper thread tension».
- > Move the slide using the touchscreen pen or the finger to increase or to reduce the upper thread tension.



- > Touch the yellow-framed icon to reset the alteration to basic setting.

## Altering the view



The view of the embroidery motif can be scaled up and downsized. In addition to that, the view can be adjusted with or without changing the embroidery position.

- > Select an embroidery motif.
- > Touch the icon «Zoom in» to edit the view of the embroidery motif.
-  > Touch the icon «Zoom in» 1 – 4 times to scale up the view of the embroidery motif gradually.
-  > Touch the icon «Zoom out» 1 – 4 times to minimize the view of the embroidery motif gradually.
-  > Touch the icon «Relocating the view».
- > Alter the view of the embroidery motif using the touchscreen pen or the finger.
  - The embroidery position is not altered.
-  > Touch the icon «Relocating the view of the embroidery motif».
- > Relocate the view of the embroidery motif using the touchscreen pen or the finger.
  - The embroidery position is altered.
-  > Touch the icon «Zoom out» to go back to the Edit Mode.

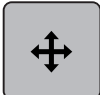
## Relocating the embroidery motif

- > Select an embroidery motif.
- > Touch the icon «i»-Dialog.
-  > Touch the icon «Relocating the embroidery motif».
-  > Turn the «Upper Multifunctional knob» to move the embroidery motif horizontally.
- > Turn the «Lower Multifunctional knob» to move the embroidery motif vertically.
- > Touch the yellow-framed icon to reset the alteration to basic setting.

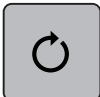
## Rotating the embroidery motif

- > Select an embroidery motif.
- > Touch the icon «i»-Dialog.
-  > Touch the icon «Rotating the embroidery motif».
-  > Turn the «Upper Multifunctional knob» or the «Lower Multifunctional knob» to the right to rotate the embroidery motif clockwise.
- > Turn the «Upper Multifunctional knob» or the «Lower Multifunctional knob» to the left to rotate the embroidery motif counter-clockwise.
-  > Touch the icon «Rotating the embroidery motif +90°» to rotate the embroidery motif in 90°-steps.
- > Touch the yellow-framed icon to reset the alteration to basic setting.

## Altering the size proportionally

- > Select an embroidery motif.
- > Touch the icon «i»-Dialog.
- 



- > Touch the icon «Altering the embroidery motif proportionally».
- > Turn the «Upper Multifunctional knob» or the «Lower Multifunctional knob» to the right to increase the size of the embroidery motif proportionally.
- > Turn the «Upper Multifunctional knob» or the «Lower Multifunctional knob» to the left to decrease the size of the embroidery motif proportionally.
- > Touch the yellow-framed icon to reset the alteration to basic setting.

### Mirroring embroidery motifs



- > Select an embroidery motif.
- > Touch the icon «i»-Dialog.



- > Touch the icon «Mirror image left/right» to mirror the embroidery motif horizontally.



- > Touch the icon «Mirror image up/down» to mirror the embroidery motif vertically.
- > Touch the yellow-framed icon to reset the alteration to basic setting.

### Changing satin stitch to step stitch



- > Select an embroidery motif.
- > Touch the icon «i»-Dialog.



- > Touch the icon «Altering the stitch type/stitch density».
- > Touch the switch in the upper portion of the display (1) to activate the step stitch.
- > Adjust the desired stitch length (2) with the icons «-» or «+».



### Altering the stitch density



- > Select an embroidery motif.
- > Touch the icon «i»-Dialog.



- > Touch the icon «Altering the stitch type/stitch density».
- > Adjust the desired stitch density (1) with the icons «-» or «+».

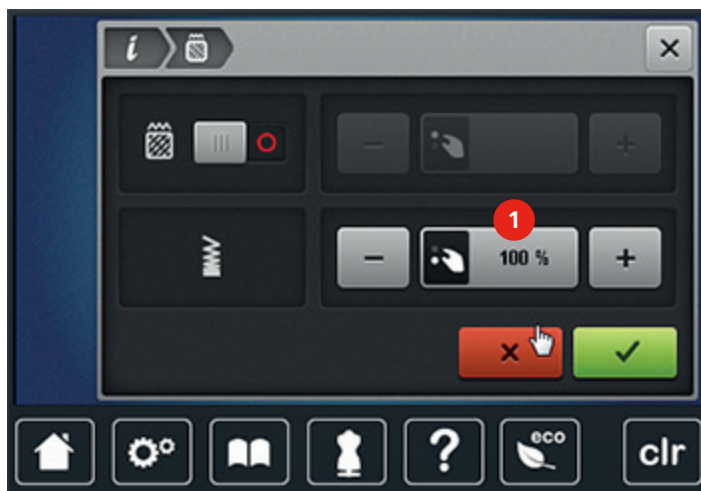

### Checking the size of the embroidery motif

It can be checked whether or not the size of the embroidery motif fits in the hoop.

- > Select an embroidery motif.
- > Touch the icon «i»-Dialog.

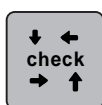

- > Touch the icon «Checking the size of the embroidery motif».
- > Touch the icon «Corner top left» to select the top left corner of the embroidery motif.
- > Touch the icon «Corner top right» to select the top right corner of the embroidery motif.
- > Touch the icon «Corner bottom left» to select the bottom left corner of the embroidery motif.
- > Touch the icon «Corner bottom right» to select the bottom right corner of the embroidery motif.



- > Touch the icon «Embroidery motif center» to select the center of the embroidery motif.
- > Turn the «Upper Multifunctional knob» to move the embroidery motif horizontally.
- > Turn the «Lower Multifunctional knob» to move the embroidery motif vertically.

## 11.9 Administering embroidery motifs

### Saving embroidery motifs in the personal memory

- > Edit the embroidery motif.
- > Touch the icon «Selection».



- > Touch the icon «Saving the embroidery motif».
  - The embroidery motif to be saved is outlined in yellow.
  - The icon «Embroidery machine» is activated.



- > Touch the icon «Confirm».

### Saving the embroidery motif on the BERNINA USB stick

- > Edit the embroidery motif.
- > Touch the icon «Selection».



- > Touch the icon «Saving the embroidery motif».
  - The embroidery motif to be saved is outlined in yellow.
- > Insert the BERNINA USB stick into the port (1).



- > Touch the icon «USB stick».



- > Touch the icon «Confirm».

### Overwriting the embroidery motif in the personal memory

- > Edit the embroidery motif.
- > Touch the icon «Selection».



- > Touch the icon «Saving the embroidery motif».
  - The embroidery motif to be saved is outlined in yellow.
  - The icon «Embroidery machine» is activated.



- > Select the embroidery motif which is to be overwritten.



- > Touch the icon «Confirm».

### Overwriting the embroidery motif on the BERNINA USB stick

- > Edit the embroidery motif.
- > Touch the icon «Selection».
- > Touch the icon «Saving the embroidery motif».
- The embroidery motif to be saved is outlined in yellow.
- > Insert the BERNINA USB stick into the port (1).



- > Touch the icon «USB stick».
- > Select the embroidery motif which is to be overwritten.
- > Touch the icon «Confirm».



### Loading an embroidery motif from the personal memory

- > Touch the icon «Selection».
- > Touch the icon «Loading embroidery motif».
- > Select the file «Personal embroidery motifs».
- > Select an embroidery motif.



### Loading an embroidery motif from the BERNINA USB stick

- > Touch the icon «Selection».
- > Insert the BERNINA USB stick into the port (1).



- > Touch the icon «USB stick».
- > Select a personal embroidery motif.

### Deleting an embroidery motif from the personal memory

The embroidery motifs which are saved in the personal memory can be deleted individually. In the Setup Program all embroidery motifs from the personal memory can be deleted (see page 60).



> Touch the icon «Selection».



> Touch the icon «Deleting embroidery motif».



– The icon «Embroidery machine» is activated.



> Select the embroidery motif which is to be deleted.

> Touch the icon «Confirm».

### Deleting an embroidery motif from the BERNINA USB stick



> Touch the icon «Selection».



> Touch the icon «Deleting embroidery motif».

> Insert the BERNINA USB stick into the port (1).



> Touch the icon «USB stick».

> Select the embroidery motif which is to be deleted.



> Touch the icon «Confirm».



## 11.10 Embroidery menu

### Overview Embroidery menu

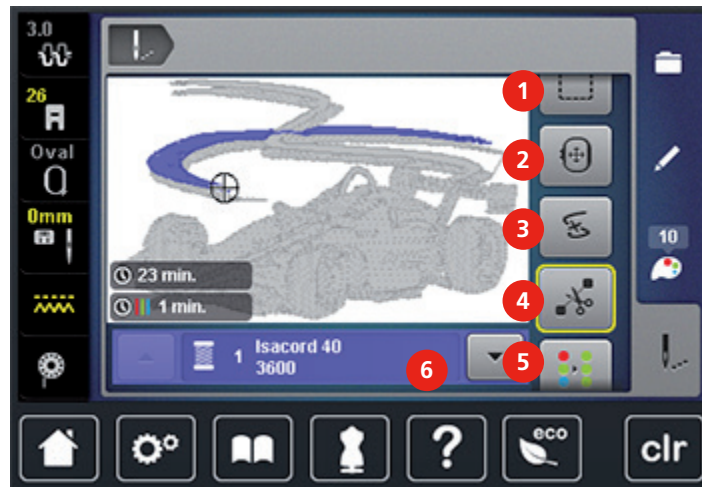

- |   |  |   |                                       |
|---|--|---|---------------------------------------|
| 1 | Basting  | 4 | Cutting connecting stitches           |
| 2 | Moving the hoop                                | 5 | Multi-colored embroidery motif on/off |
| 3 | Embroidery sequence control when thread breaks | 6 | Color indication                      |

### Changing the colors of the embroidery motif



Lettering is always embroidered in one color. To embroider single letters or single words in another color, every letter or every word has to be selected individually and placed in the embroidering area.



- > Select an embroidery motif.
- > Touch the icon «Colors».

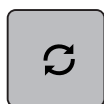

- > Touch the icon «Altering color/brand» next to the color which is to be changed.
- > Using the touchscreen pen or the finger, wipe on the display upwards or downwards to see other colors.



- > Touch the icon «Color selection by number» to select the color by entering the color number.
- > Select the desired color.



- > Touch the icon «Embroidering».





### Changing the thread brand







- > Select an embroidery motif.
- > Touch the icon «Colors».



- > Touch the icon «Altering color/brand».





-  > Touch the icon «Scrolling top right» to see other thread brands.
-  > Using the touchscreen pen or the finger, wipe on the display upwards or downwards to see other thread brands.
-  > Change all thread brands.
-  > Touch the icon «Embroidering».

### Adding basting stitches

-  > Select an embroidery motif.
-  > Touch the icon «Embroidering».
-  > Touch the icon «Basting» to embroider basting stitches along the embroidery motif.
-  > Touch the icon «Basting» again to embroider basting stitches along the embroidery hoop.
-  > Touch the icon «Basting» again to deactivate the basting stitches.







### Moving the hoop

If an embroidery motif is so big that repeated rehooping is necessary, it is possible to move the hoop to the last stitch of the already embroidered motif.

-  > Select an embroidery motif.
-  > Touch the icon «Embroidering».
-  > Touch the icon «Relocating the hoop».
-  > Turn the «Upper Multifunctional knob» to move the hoop horizontally.
-  > Turn the «Lower Multifunctional knob» to move the hoop vertically.

### Repositioning the needle

When the thread breaks, the needle can be repositioned in the embroidery motif by means of the embroidery sequence control.

-  > Select an embroidery motif.
-  > Touch the icon «Embroidering».
-  > Touch the icon «Embroidery sequence control when thread breaks».
  - In the left portion of the display a compact view of the embroidery motif is displayed. On the right side the enlarged embroidery motif is displayed.
-  > Select the desired position in the compact view using the touchscreen pen or the finger.
-  > Turn the «Upper Multifunctional knob» to move the hoop stitch by stitch.
-  > Turn the «Lower Multifunctional knob» to move the hoop in large steps.
-  > Touch the icon «0–9» to select the desired stitch by entry.

## Cutting connecting stitches

The function is activated by default and the connecting stitches are cut automatically. When the function is deactivated, the connecting stitches between the embroidery motifs must be cut manually.

- > Select an embroidery motif.
- > Touch the icon «Embroidering».



- > Touch the yellow-framed icon «Cutting the connecting stitches» to deactivate the function.



## Embroidering motifs in one color

- > Select an embroidery motif.
- > Touch the icon «Embroidering».



- > Touch the icon «Multi-colored embroidery motif on/off».

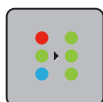

## Embroidering single colors

Every color of an embroidery motif can be selected individually. The hoop moves to the first stitch of the current color. The currently active color can be embroidered individually or in another sequence. The connecting stitches remain visible.

- > Select an embroidery motif.
- > Touch the icon «Embroidering».



- > Touch the icon «Scrolling down» to select the next color of the embroidery motif.



- > Touch the icon «Scrolling up» to select the previous color of the embroidery motif.



## 11.11 Embroidering via the button «Start/Stop»



- > Press the button «Start/Stop» until the embroidery machine starts.
  - The embroidery machine embroiders ca. 7 stitches and stops automatically.
- > Raise the Embroidery foot.
- > Cut the thread ends at the start according to the animation.
- > Press the button «Start/Stop» and resume embroidering.
  - All parts of the motif being in the current color are embroidered.
  - The embroidery machine stops automatically at the end.
  - Both threads are cut automatically.
  - The embroidery machine switches to the next color automatically.
- > Change the upper thread.
- > Embroider the new color.
  - After having finished the embroidery motif, the machine stops automatically and the threads are cut automatically.

## 11.12 Embroidering via the foot control

Embroidering via the foot control is recommended when only a short sequence has to be embroidered. While embroidering, the foot control must be pressed down all the time.

- > Press the foot control to start embroidering.
  - The embroidery machine embroiders ca. 7 stitches and stops automatically.
- > Release the foot control.
- > Raise the Embroidery foot.
- > Cut the thread ends at the start according to the animation.
- > Press the foot control and resume embroidering.

## 11.13 Creating lettering



Lettering is always embroidered in one color. To embroider single letters or single words in another color, every letter or every word has to be selected individually and placed in the embroidering area.

Lettering can be positioned within the hoop as you like. When the embroidery motif is positioned outside the embroidering area, the hoop is outlined in red on the display. With the hoop selection it can be checked whether or not the embroidery motif can be embroidered in another hoop. When the lettering does not fit in any hoop, two single words can be combined and positioned below each other as the following example will show.



- > Select the folder «Alphabets».
- > Select the font.
- > Enter the text «Made to».
- > Touch the icon (1) (standard setting) to use upper case letters.
- > Touch the icon (2) to use lower case letters.
- > Touch the icon (3) to use numbers and mathematic characters.
- > Touch the icon (4) to use special characters.



- > Touch the icon «DEL» to delete single letters of the entered text.



- > Touch the icon «Confirm» to accept the text.



- > Touch the icon «Embroidery hoop display/Embroidery hoop selection».
- > Select the hoop.
- > Touch the icon «Embroidery hoop display/Embroidery hoop selection» again to go back to the Edit Mode.



> Touch the icon «i»-Dialog.

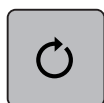

> Touch the icon «Rotating the motif».



> Touch the icon «+90», to rotate the text by 90°.

> Touch the icon «i» (1).

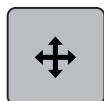

> Touch the icon «Relocating the embroidery motif».

> Turn the «Upper Multifunctional knob» to move the embroidery motif horizontally.

> Turn the «Lower Multifunctional knob» to move the embroidery motif vertically.

> Touch the yellow-framed icons to reset the alterations to basic settings.



## 12 Attachment

### 12.1 Maintenance and cleaning

#### Cleaning the display

- > Clean the display with a soft damp cloth.

#### Cleaning the feed dog

**CAUTION** Electronically driven components.

Risk of injury near the needle and the hook.

- > Switch the machine off and disconnect it from the power supply system.

Remove the thread remnants under the stitch plate regularly.

- > Remove the presser foot and the needle.
- > Push the button «Feed dog up/down» (1) to lower the feed dog.



- > Remove the stitch plate.
- > Clean the feed dog with the brush.

#### Lubricating the machine

**CAUTION** Electronically driven components.

Risk of injury near the needle and the hook.

- > Switch the machine off and disconnect it from the power supply system.

Prerequisite:

- The stitch plate is removed.
- > Fill the oil depot with 1 drop of the supplied BERNINA oil.

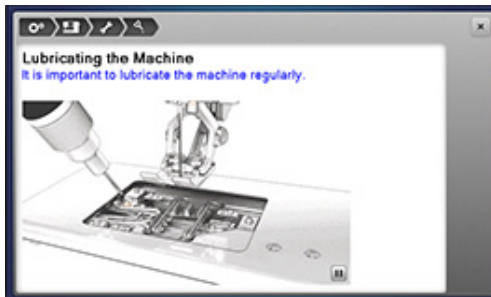

## Cleaning the hook

**⚠ CAUTION** Electronically driven components.

Risk of injury near the needle and the hook.

> Switch the machine off and disconnect it from the power supply system.

- > Open the bobbin cover.
- > Remove the bobbin case.
- > Press the release lever to the left.

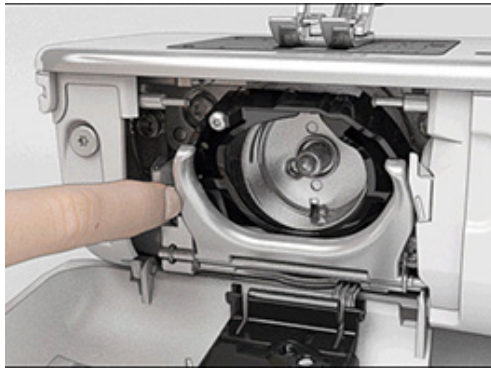

- > Flap down the fastening bracket along with the black hook race cover.
- > Remove the hook.

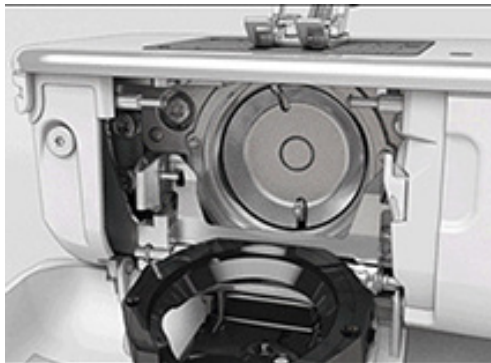

- > Clean the hook race with a brush; do not use any pointed objects.
- > Hold the hook at the pin in the center with two fingers.
- > Lead the hook, lower edge ahead, angular top-down behind the hook race cover.
- > Position the hook with the two lugs meeting the openings in the hook, the colored mark on the hook driver should be visible through the hole in the hook.
- > Insert the hook.
  - The hook is magnetic and therefore fastened to the correct position.
- > Close the hook race cover and the fastening bracket until the release bracket engages.
- > As a check, turn the handwheel.
- > Insert the bobbin case.

## Lubricating the hook

### CAUTION Electronically driven components.

Risk of injury near the needle and the hook.

- > Switch the machine off and disconnect it from the power supply system.

- > The bobbin case is removed.
- > Push the release lever to the left.

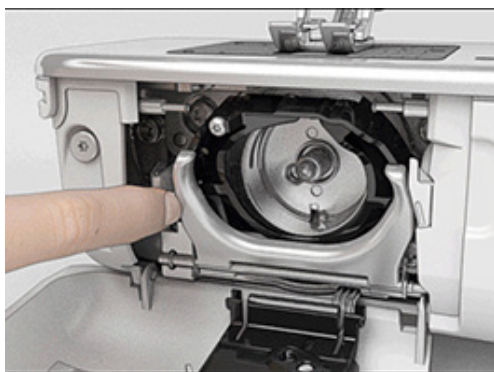

- > Flap down the fastening bracket along with the black hook race cover.
- > Remove the hook.



- > Fill as much BERNINA-oil into both oil depots so that the felts are damp and make sure that the surface of the hook sleeve (marked in red) remains free of oil.



- > Hold the hook at the pin in the center with two fingers.
- > Lead the hook, lower edge ahead, angular top-down behind the hook race cover.
- > Position the hook with the two lugs meeting the openings in the hook, the colored mark on the hook driver should be visible through the hole in the hook.
- > Insert the hook.
  - The hook is magnetic and therefore fastened to the correct position.
- > Close the hook race cover and the fastening bracket until the release bracket engages.











## 12.2 Troubleshooting



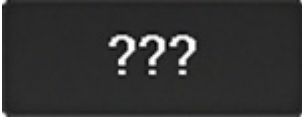

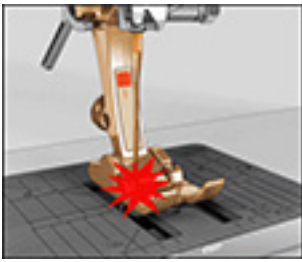
Fault	Cause	Repair
<b>Uneven stitch formation</b>	Upper thread too tight or too loose.	> Adjust upper thread tension.
	Needle blunt or bent.	> Replace the needle, make sure that a new BERNINA quality needle is used.
	Poor quality needle.	> Use a new BERNINA quality needle.
	Poor quality thread.	> Use quality thread.
	Incorrect needle/thread combination.	> Match the needle with the thread size.
	Incorrectly threaded.	> Rethread.
	The fabric has been pulled.	> Feed the fabric evenly.
<b>Uneven stitch formation</b>	The incorrect bobbin case is used.	> Use the supplied bobbin case with triangles.
		
<b>Skipped stitches</b>	Incorrect needle.	> Use the needle system 130/705H.
	Needle blunt or bent.	> Replace the needle.
	Poor quality needle.	> Use a new BERNINA quality needle.
	The needle is incorrectly inserted.	> Insert the needle with the flat side to the back as far up as it will go and tighten the screw.
	Incorrect needle point.	> Match the needle point to the texture of the material.
<b>Faulty stitching</b>	Thread remnants between the thread tension discs.	> Fold a piece of thin material and slide the folded edge (not the raw edges) between the thread tension discs.
	Incorrectly threaded.	> Rethread.
	Thread remnants below the bobbin case spring.	> Remove the thread remnants under the spring.





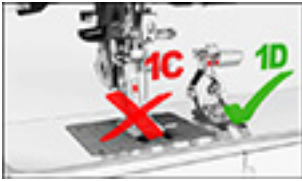

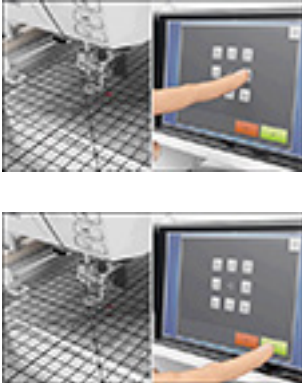

Fault	Cause	Repair
<b>Sewing speed too low</b>	Unfavorable room temperature.	> Place the machine in a warm room one hour before use.
	Settings in the Setup Program.	> Adjust the sewing speed in the Setup Program. > Adjust the slide.
<b>The machine doesn't start</b>	Unfavorable room temperature.	> Place the machine in a warm room one hour before use. > Connect the machine and switch it on.
	The machine is damaged.	> Contact the specialized BERNINA dealer.
<b>The light of the «Start-/Stop» button doesn't light up</b>	Light is defect.	> Contact the specialized BERNINA dealer.
<b>Neither the sewing light nor the light on the free arm lights up</b>	Settings in the Setup Program.	> Activate it in the Setup Program.
	The sewing light is defect.	> Contact the specialized BERNINA dealer.
<b>Upper thread indicator doesn't react</b>	Settings in the Setup Program.	> Activate it in the Setup Program.
	The upper thread indicator is defect.	> Contact the specialized BERNINA dealer.
<b>Bobbin thread indicator doesn't react</b>	Settings in the Setup Program.	> Activate it in the Setup Program.
	The bobbin thread indicator is defect.	> Contact the specialized BERNINA dealer.
<b>Error during software update</b>	USB stick is not recognized.	> Use a BERNINA USB stick.
	The update process is blocked and the hourglass on the display is inactive.	> Remove the USB stick. > Switch the machine off. > Switch the machine on. > Follow the instruction on the display.
	Date of the software update cannot be found.	> Unzip the update data. > Save data of the software update directly on the data medium and not in a file on the USB stick.

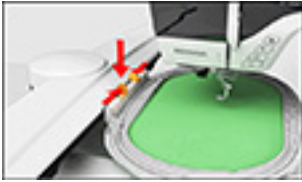
## 12.3 Error messages

Message on the display	Cause	Repair
	Stitch number unknown.	> Check the entry and enter the new number.
	Selection of the stitch pattern not possible in the combi mode.	> Combine other stitch patterns.
	The feed dog is not lowered.	> Press the button «Feed dog up/down» to lower the feed dog.
	The selected needle and stitch plate cannot be used in combination.	> Replace the needle. > Replace the stitch plate.
	The needle is not at its top end.	> Adjust the needle position via the handwheel.
	The upper thread is used up.	> Rethread.
	The upper thread has broken.	> Rethread.
	The bobbin thread is used up.	> Rethread.
	The bobbin thread has broken.	> Clean the hook. > Rethread.

Message on the display	Cause	Repair
	The main motor isn't running.	<ul style="list-style-type: none"> <li>&gt; Clean the hook.</li> <li>&gt; Remove the hook and make sure that there are no pieces of broken needle points on the magnetic back of the hook.</li> <li>&gt; Deactivate the thread catcher in the Setup Program.</li> </ul>
	Incorrect presser foot for the BERNINA Dual Transport.	<ul style="list-style-type: none"> <li>&gt; Attach a presser foot with the labeling «D».</li> </ul>
	The fabric under the presser foot is too thick.	<ul style="list-style-type: none"> <li>&gt; Reduce the fabric thickness.</li> </ul>
	The contact between the machine and the embroidery module is interrupted due to vibrations.	<ul style="list-style-type: none"> <li>&gt; Make sure that the module and the machine are standing on a stable, even surface.</li> <li>&gt; Connect the embroidery modul to the machine.</li> </ul>
	The needle position doesn't correspond with the center of the hoop.	<ul style="list-style-type: none"> <li>&gt; Calibrate the hoop.</li> </ul>
	The embroidery module is not attached.	<ul style="list-style-type: none"> <li>&gt; Connect the embroidery modul to the machine.</li> <li>&gt; Contact the specialized BERNINA dealer to have the machine checked.</li> </ul>

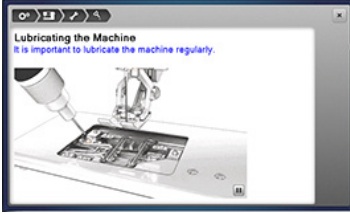
Message on the display	Cause	Repair
	The hoop is not attached.	> Attach the hoop.
	The hoop is attached.	> Remove the embroidery hoop.
	The movement of the hoop follows.	> Touch the icon «Confirm».
	The embroidery motif is partly outside the hoop.	> Reposition the embroidery motif and start embroidering it again.
	The embroidery motif is too large.	> Reduce the size of the embroidery motif. > Attach a bigger hoop.
Too less free capacity on the BERNINA USB stick (optional accessory).	Not enough free capacity on the BERNINA USB stick (optional accessory).	> Make sure that the BERNINA USB stick (optional accessory) is used. > Delete data from the BERNINA USB stick (optional accessory).
No personal data on the BERNINA USB stick (optional accessory).	No personal data for recovery available on the BERNINA USB stick (optional accessory).	> Make sure that the data and settings have been saved on the BERNINA USB stick (optional accessory).

Message on the display	Cause	Repair
The recovery of personal data has failed.	The software update has been successful but the personal data couldn't be recovered.	<ul style="list-style-type: none"> <li>&gt; Make sure that the data and settings have been saved on the BERNINA USB stick.</li> <li>&gt; Transfer saved data to the machine.</li> </ul>
No BERNINA USB stick is inserted. Make sure that during the complete automatic update always the same BERNINA USB stick remains inserted.	The BERNINA USB stick (optional accessory) is not inserted.	<ul style="list-style-type: none"> <li>&gt; Use a BERNINA USB stick (optional accessory) providing enough free capacity.</li> </ul>
The update of the software has failed.	The latest software version cannot be found on the USB stick.	<ul style="list-style-type: none"> <li>&gt; Make sure that the data for the software update has been unzipped.</li> <li>&gt; Check whether the data for the software update are saved directly on the data medium and not in a file on the USB stick.</li> <li>&gt; Update the software.</li> </ul>
 	The machine needs cleaning/lubricating.	<ul style="list-style-type: none"> <li>&gt; Clean the machine.</li> <li>&gt; Lubricate the machine.</li> </ul>
It is time for the regular maintenance. Please contact your specialized BERNINA dealer to make an appointment.	<p>The machine needs maintenance. The message appears after the programmed service interval has expired.</p> <p><b>Important Information:</b> Having your machine cleaned and serviced properly at the appropriate times ensures its proper functioning and a long service life. Failure to do so may adversely affect service life and limit the guarantee. The charge for servicing is nationally regulated – consult your dealer or servicing shop for more details.</p>	<ul style="list-style-type: none"> <li>&gt; Contact the specialized BERNINA dealer.</li> <li>&gt; The message can be temporarily deleted by touching the icon «ESC».</li> </ul> <p>Having cleared the message three times, the message will appear as recently as the next service interval has been completed.</p>



## 12.4 Storage and disposal

### Storing the machine

It is recommended to store the machine in the original packaging. If the machine is stored in a cold room, place it in a warm room one hour before use.

- > Switch the machine off and disconnect it from the power supply system.
- > Don't store the machine outdoor.
- > Protect the machine against climatic influences.

### Dispose of the machine

BERNINA International AG is committed to the protection of the environment. We strive to minimize the environmental impact of our products by continuously improving product design and our technology of manufacturing.

When the machine won't be used anymore, dispose this product in an environmentally responsible way according to the national directive. Do not throw away this product with your household waste. When in doubt, bring the machine to your local specialized BERNINA dealer.

- > Clean the machine.
- > Sort the components by their materials and dispose of them according to the local laws and regulations.

## 12.5 Technical data

Term	Value	Measurement unit
Maximum fabric thickness	12.5	mm
Sewing light	30	LED
Maximum sewing speed	1000	spm/rpm
Measurements without the spool pin	522/214/358	mm
Weight	14	kg
Energy consumption	140	Watt
Input voltage	100-240	Volt
Protection class (Electrical engineering)	II	

## 12.6 Overview Stitch patterns

### Practical stitches































1	2	3	4	5	6	7	8	9	10	11
12	13	14	15	16	17	18	19	20	21	22
23	24	25	26	29	31	32	33			

### Buttonholes





















51	52	53	54	56	57	59	63	64	65	69
60	61	62								

## Decorative stitches

































### Florals

101	102	103	104	107	108	110	111	112	113	114
										
115	119	122	123	124	125	129	133	134	136	137
										
143	144	145	146	147	149	150	151	152		
										

### Cross stitches

301	302	303	304	305	306	307	308	309	311	314
										
323	326	371	372	373	374	375	376	377		
										

### Satin stitches

401	402	405	406	407	408	412	413	414	415	416
										
417	419	422	423	424	425	426	428	429	430	431
										
437	439	441	442	445	446	447	448	450	451	457
										

461	464	465	468	471	473					

Ornamental stitches

601	602	603	604	605	606	607	608	609	610	611
612	613	614	615	616	618	619	621	622	623	624
625	626	630	631	633	635	639	640	641	642	643
644	645	648	649	651	653	656	657	658	660	661
662	663	664	677	679	680	681	682	683	684	685
686	690	692	694	697	698	699				

Heirloom stitches

701	702	705	706	708	709	710	711	712	713	714
717	719	720	721	722	723	724	725	726	727	728

730	731	732	734	735	736	737	738	740	741	742
743	746	747	748	749	750	751	761	763	764	765
766	767	768	769	772	775	777	779			

## Novelty

903	904	906	907	908	911	913	914	916	919	920
921	925	929	930	934	935	937	938	939	940	941
942	943	944	945	946	947	948				

## Quilt stitches

1324	1325	1326	1327	1328	1329	1330	1331	1332	1333	1334
1335	1336	1337	1338	1339	1340	1341	1342	1343	1344	1345
1346	1347	1348	1350	1351	1352	1353	1354	1355	1356	1357
6 / inch 2.4 cm	8 / inch 3.2 / cm	10 / inch 4 / cm	irregular look							

1358	1359	1360	1361	1362	1363	1364	1365	1366	1367	1368
1369	1370	1388	1389	1390	1393					

## 12.7 Overview Embroidery motifs

### Editing embroidery motifs













Let your inspiration run free. A vast selection of embroidery motifs is at your disposal.

If you see one of the following pictograms below a number of an embroidery motif, you can find additional information at [www.bernina.com/7series](http://www.bernina.com/7series).

	Detached point		CutWork Design (motif)
	Broderie anglaise		PaintWork Design (motif)
	Fringes		CrystalWork Design (motif)
	Appliqué		PunchWork







### Quilt

No.	Embroidery motif Colors	Width x Height in mm	No.	Embroidery motif Colors	Width x Height in mm
12380-22		110.6 60.9	12380-43		123.5 123.5







No.	Embroidery motif Colors	Width x Height in mm	No.	Embroidery motif Colors	Width x Height in mm
12380-30	 ■	89.2 96.3	12380-04	 ■	83.1 89.8
12380-08	 ■	89.2 89.1	12380-09	 ■	111.6 61.6
12380-10	 ■	152.0 356.7	BD800_48	 ■	127.3 122.4
BD801_48	 ■	122.2 124.2	BD804_48	 ■	122.9 123.6
BD796_48	 ■	47.2 174.5	BD837_48	 ■	123.6 123.6
BD285	 ■	99.8 99.7	BD288	 ■	96.3 96.0















No.	Embroidery motif Colors	Width x Height in mm	No.	Embroidery motif Colors	Width x Height in mm
BD292	 ■	94.8 95.1	BD289	 ■	95.0 94.7
BD299	 ■	94.5 95.0	BD308	 ■	95.0 94.4
BD413_48	 ■	97.1 97.2	BD554_48	 ■	109.9 109.9
BD553_48	 ■	113.8 121.1	BD567_48	 ■	107.9 108.2
BD394_48	 ■	97.0 96.8	BD412_48	 ■	89.4 53.2
BD501_48	 ■	63.5 61.1	BD502_48	 ■	61.5 60.7





No.	Embroidery motif Colors	Width x Height in mm	No.	Embroidery motif Colors	Width x Height in mm
BD513_48		63.5 63.4	BD514_48		63.5 62.9
BD562		63.9 126.0	BD568		109.5 160.3
BD563		89.7 89.6	BD569_48		120.6 120.6







### Embellishment



















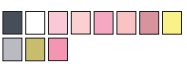

No.	Embroidery motif Colors	Width x Height in mm	No.	Embroidery motif Colors	Width x Height in mm
82007-11 		111.7 94.2	82007-44		114.0 114.8
82006-30 		99.9 174.6	NB251_48		71.6 103.3

No.	Embroidery motif Colors	Width x Height in mm	No.	Embroidery motif Colors	Width x Height in mm
BE790405	 ■	125.9 185.4	FB126	 ■ ■	86.9 102.2
BE790407	 ■	199.9 270.9	BE790502	 ■	59.9 58.2
21003-26 	 ■ ■ ■	123.0 124.1	NB403_48	 ■ ■ ■	78.1 78.3
NB373_48	 ■	121.4 176.8	NB442_48	 ■ ■ ■	55.6 58.4
NB481_48	 ■ ■	123.4 67.6	NB749_48	 	126.5 262.8
NA959_48 	 ■ ■ ■ ■ ■ ■ ■ ■	75.6 103.7	FB106	 ■ ■	128.1 92.6

No.	Embroidery motif Colors	Width x Height in mm	No.	Embroidery motif Colors	Width x Height in mm
NB002_48		59.3 35.1	FQ870_48		122.1 105.1
WS655_48		116.5 222.3			



















### Flowers



















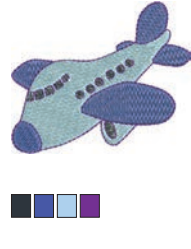



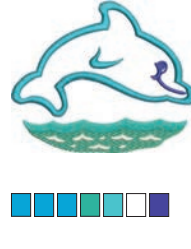

No.	Embroidery motif Colors	Width x Height in mm	No.	Embroidery motif Colors	Width x Height in mm
82006-07		123.7 165.6	21006-02		114.5 135.5
80001-23		85.0 101.6	12457-06		106.3 172.3
12457-13		113.1 130.3	21009-21		64.9 107.7



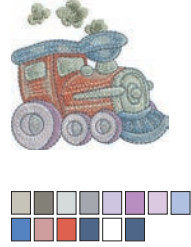





No.	Embroidery motif Colors	Width x Height in mm	No.	Embroidery motif Colors	Width x Height in mm
BE790408	 	58.3 89.7	BE790401	 	205.7 242.0
21002-02	 	109.7 160.0	21012-04 	 	123.1 123.9
FB492_48	 	86.8 293.2	FP246	 	65.6 61.8
FP814	 	88 84.4	FQ562_48	 	90.3 156.3
FQ722_48	 	80.0 90.6	FQ733_48	 	66.5 66.5

No.	Embroidery motif Colors	Width x Height in mm	No.	Embroidery motif Colors	Width x Height in mm
FQ801_48	 	46.0 112.5	NB209_48	 	90.0 89.9

### Children





















No.	Embroidery motif Colors	Width x Height in mm	No.	Embroidery motif Colors	Width x Height in mm
BE790307 	 	141.5 126.9	BE790311 	 	114.1 152.5
BE790305 	 	118.3 145.5	BE790306 	 	132.1 151.4
BE790308 	 	191.3 219.6	BE790309 	 	87.5 149.8

No.	Embroidery motif Colors	Width x Height in mm	No.	Embroidery motif Colors	Width x Height in mm
BE790310 	 	137.8 136.0	BE790312 	 	122.0 133.1
BE790313 	 	98.9 102.3	CK511	 	76.2 64.6
CM193_48 	 	106.7 127.4	CK667 	 	99.8 82.3
CK738	 	89.1 85.7	CK970	 	84.8 81.6
CM147	 	55.0 99.6	CM220_48 	 	71.5 71.8

No.	Embroidery motif Colors	Width x Height in mm	No.	Embroidery motif Colors	Width x Height in mm
CM348_48	 	119.0 167.1	CM362_48 	 	120.6 113.0
CM376_48	 	100.3 97.5	NB193_48	 	113.3 96.2





### Borders and Lace







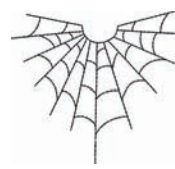







No.	Embroidery motif Colors	Width x Height in mm	No.	Embroidery motif Colors	Width x Height in mm
21013-29	 	40.2 152.0	BE110415	 	43.7 172.4
FA981	 	35.1 142.3	21002-21	 	21.6 150.9
21009-29	 	31.9 152.6	82005-40	 	26.0 239.4

No.	Embroidery motif Colors	Width x Height in mm	No.	Embroidery motif Colors	Width x Height in mm
BE790702	 	73.0 190.5	NA914_48	 	120.3 18.8
NB520_48	 	26.3 175.9	HG177_48	 	50.0 158.6
CM473_48	 	31.8 209.6	FB436_48	 	132.8 29.2NX
NX696	 	91.2 90.7	HG341_48	 	63.8 63.7
NX957	 	97.9 88.1	FB461_48 	 	121.7 121.6



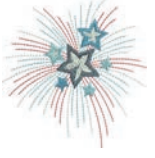















## Seasons

No.	Embroidery motif Colors	Width x Height in mm	No.	Embroidery motif Colors	Width x Height in mm
12433-05 	 	83.4 124.4	12417-04	 	84.3 97.1
BE790303	 	69.5 70.1	BE790301	 	127.2 89.0
GNNF80834	 	95.2 78.8	HE962_48	 	120.5 135.2
12421-11	 	39.9 43.6	12421-37	 	67.4 61.0
12421-03	 	45.8 48.3	CM287_48	 	90.4 117.2







No.	Embroidery motif Colors	Width x Height in mm	No.	Embroidery motif Colors	Width x Height in mm
CM426_48	 	45.8 96.0	FQ749_48	 	77.6 94.8
HE919_48	 	89.1 69.2	HG053_48	 	122.1 121.8
HG319_48	 	88.6 151.5	HG460_48	 	91.8 98.1
NB317_48	 	87.4 86.9			



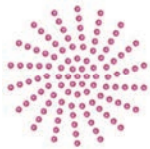









### Hobby/Sports

No.	Embroidery motif Colors	Width x Height in mm	No.	Embroidery motif Colors	Width x Height in mm
SR589	 	95.2 66.5	LT870	 	97.5 57.0

No.	Embroidery motif Colors	Width x Height in mm	No.	Embroidery motif Colors	Width x Height in mm
RC244	 	88.4 53.4	SP980	 	63.2 63.5
SP989	 	101.6 82.5	SR067	 	87.5 96.9
FB148_48	 	101.1 89.5	SR551	 	120.3 38.0

### CrystalWork

No.	Embroidery motif Colors	Width x Height in mm	No.	Embroidery motif Colors	Width x Height in mm
DW11 			BE790901 		
BE790903 			BE790905 		

No.	Embroidery motif Colors	Width x Height in mm	No.	Embroidery motif Colors	Width x Height in mm
BE790906 			BE790909 		
DW07 			DW05 		
DW10 			DW08 		



## R

---

Raising/Lowering the needle	33
Registering details of the dealer	65
Regulating the sewing speed	69
Relocating the hoop	138

## S

---

Safety instructions	13
Saving Service data	65
Selecting a language	58
Selecting a stitch pattern	67
Selecting an embroidery motif	135
Selecting personal settings	56
Sewing a test sample	110
Sewing with connected embroidery module	138
Storage and disposal	163, 164
Supplied accessories	124

## T

---

Threading preparation	41
Threading the bobbin thread	46
Threading the double needle	44
Threading the triple needle	45
Threading the upper thread	41
Troubleshooting	156

## U

---

Updating the software	61
Using a spool net	34
Using eco mode	81

## W

---

Winding the bobbin thread	45
---------------------------	----



