

bernette
sew&go 1
sew&go 3
sew&go 5



Instruction Manual



www.mybernette.com

IMPORTANT

When using an electrical machine, basic safety precautions should always be followed, including the following:

Please read the instruction manual carefully before using this machine.

Keep the instruction manual at a suitable place with the machine and hand it over if you give the machine to a third party.

When the machine is not in use or left unattended, always disconnect the machine from the power supply system. Unplug it from the outlet.

DANGER!

To reduce the risk of electric shock:

1. Never leave the machine unattended when it is plugged in.
2. Always unplug this machine from the electric outlet immediately after using and before cleaning.
3. LED RADIATION: Do not view directly with optical instruments Class.

WARNING!

To reduce the risk of burns, fire, electric shock or injury to persons:

1. The machine mustn't be used by children under 8 or by people with reduced physical,

sensory or mental capabilities or if there is a lack of experience and knowledge how to operate the machine. Unless they have been given instruction concerning the use of the machine and the involved risks by a person who is responsible for their safety.

2. Do not use this machine as a toy. Close attention is necessary when this machine is used by children, near children or people with reduced sensation.
3. Use this machine only for its intended use as described in this manual. Use only accessories recommended by the manufacturer.
4. Children should be supervised to ensure that they do not play with the machine.
5. Never operate this machine if it has a damaged cord or plug, if it is not working properly, if it has been dropped or damaged, or dropped into water. Return the machine to the nearest authorized dealer or service centre for examination, repair, electrical or mechanical adjustment.
6. Never operate the machine with any air openings blocked. Keep ventilation openings of the machine and the foot control free from accumulation of lint, dust, and loose cloth.
7. Keep fingers away from all moving parts. Special care is required around the machine needle.
8. Always use the proper stitch plate. The wrong plate can cause needle breakage.
9. Do not use bent needles.
10. Do not pull or push the fabric while sewing. This can result in needle breakage.
11. Switch the machine off ("O") when making any adjustments in the needle area, such as threading or changing the needle, threading the bobbin, or changing the presser foot, and the like.

12. Always unplug the machine when performing cleaning or maintenance work such as replacing the sewing light or when making any other user maintenance adjustments mentioned in the instruction manual (disconnect the power plug). Cleaning and maintenance work must not be carried out by children without supervision.
13. Never drop or insert any object into any openings.
14. Use this machine only in dry and protected areas. Never operate the machine in a damp or wet environment.
15. Do not operate the machine where aerosol spray products are being used or where oxygen is being administered.
16. To disconnect, turn the power switch to ("O")(off), then remove the plug from the outlet. Do not unplug by pulling the cord, instead grasp the plug to pull it from the outlet.
17. If the supply cord of the foot control is damaged, it must be replaced by the manufacturer or an appropriate service agent or a similar qualified person in order to avoid endangerment.
18. Never place anything on the foot control.
19. When replacing the light bulb, always use the same type.
20. The machine may only be used in combination with a foot control of the type KD-1902, FC-1902 (110-120V area) / KD-2902, FC-2902A, FC-2902D (220-240V area) / 4C-316B (110-125V area) / 4C-316C (127V area) / 4C-326C(220V area) / 4C-326G (230V area) / 4C-336G (220-240V area)..
21. The sound pressure level during normal operation is lower than 75dB(A).
22. This machine is provided with double insulation (except U.S./Canada). Use only identical replacement parts. See instructions for Servicing of double-insulated products.

SERVICING OF DOUBLEINSULATED PRODUCTS

In a double-insulated product, two systems of insulation are provided instead of grounding. No grounding means is provided on a double-insulated product nor should a means for grounding be added to the product. Servicing a doubleinsulated product requires extreme care and knowledge of the system and should only be done by qualified service personnel. Replacement parts for a double-insulated product must be identical to those parts in the product. A double insulated product is marked with the words "DOUBLE INSULATION" or "DOUBLE INSULATED".

The symbol  may also be marked on the product.

SAVE THESE INSTRUCTIONS!

Attention!

- This machine is intended for household use only. If used intensively or commercially, regular cleaning and especially attentive care is required.
- Signs of wear and tear owing to intensive or commercial use are not covered automatically, even if they occur within the warranty period. The decision on how to deal with any such cases rests with the local authorised servicing staff.

Note:

If the machine is stored in a cold room, it should be brought to a warm room about one hour before use.

All rights reserved

For technical and product improvement reasons, the machine's features, parts and accessory are subject to unannounced changes and alterations at any time. The accessory included can differ from country to country.

**Environmental protection**

BERNINA is committed to the protection of the environment. We strive to minimize the environmental impact of our products by continuously improving product Design and our technology of manufacturing.

Do not dispose of electrical machines as unsorted municipal waste, use separate collection facilities.

Contact your local government for information regarding the collection systems available.

If electrical machines are disposed of in landfills or dumps, hazardous substances can leak into the groundwater and get into the food chain, damaging your health and well-being.

When replacing old machines with new ones, the retailer is legally obligated to take back your old machine for professional disposal free of charge.

Machine overview	7	Blind hem / lingerie stitch	27
Accessories	9	Overlock stitches	28
Machine preparation	10	Sewing on buttons (for sew&go 1/3).....	29
Sewing table	10	Sewing on buttons (for sew&go 5).....	30
Connecting machine to power source.....	11	Sew 4-step buttonholes (for sew&go 1/3).....	31
Adjusting presser foot pressure	12	Sew 1-step buttonholes (for sew&go 5).....	32
Presser foot lifter.....	13	Buttonhole on stretch fabrics	33
Darning plate	13	Zippers	34
Changing the presser foot	14	Sewing with the hemmer foot	35
Winding the bobbin	15	3-step zig-zag	36
Inserting bobbin	16	Triple straight / zigzag.....	37
Inserting the needle	17	Smocking stitch.....	38
Threading the upper thread	18	Darning	39
Automatic needle threader.....	19	Practical stitches	40
Thread tension	20	Quilting.....	41
Raising the bobbin thread	21	Patch work	42
Matching needle/fabric/thread	22	Applique.....	43
Stitch selection.....	23	Twin needle.....	44
Stitch width dial & stitch length dial.....	24	Monogramming and embroidery	45
Sewing		Maintenance	47
Sewing straight stitch.....	25	Trouble shooting guide	48
Securing a seam (beginning and ending the seam)	26		

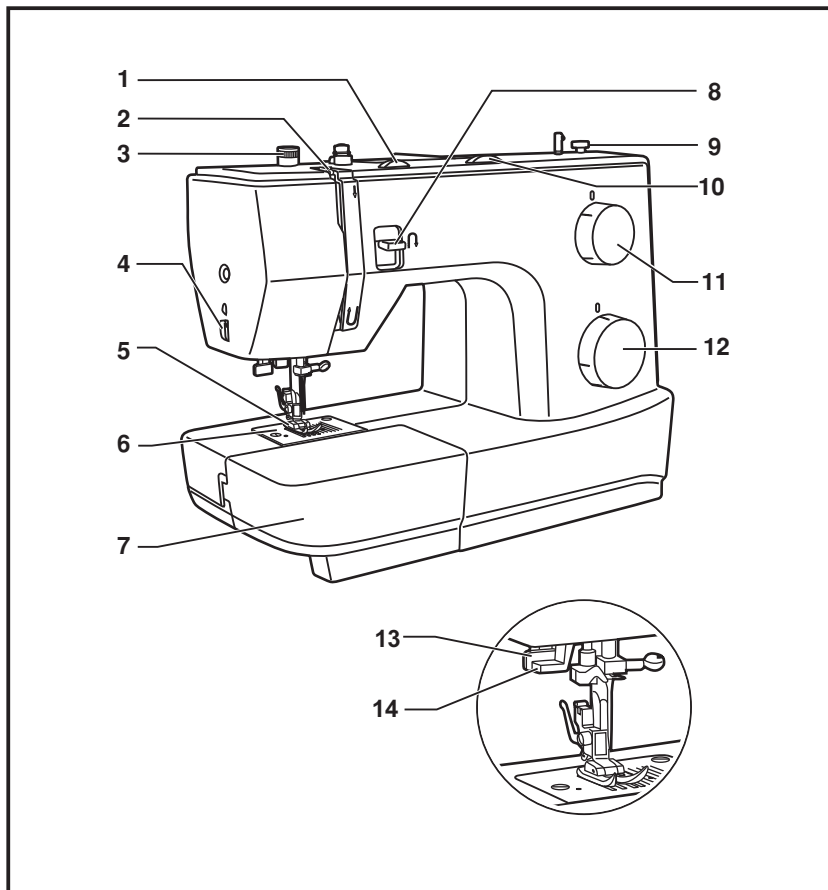

1. Thread tension dial
2. Thread take-up lever
3. Presser foot pressure adjustment
4. Thread cutter
5. Presser foot
6. Stitch plate
7. Sewing table and accessory box
8. Reverse sewing lever
9. Bobbin winder stopper
10. Stitch width dial (model sew&go 5)
11. Stitch length dial
12. Stitch selector dial
13. One step buttonhole lever (model sew&go 3 / 5)
14. Automatic threader (model sew&go 3 / 5)

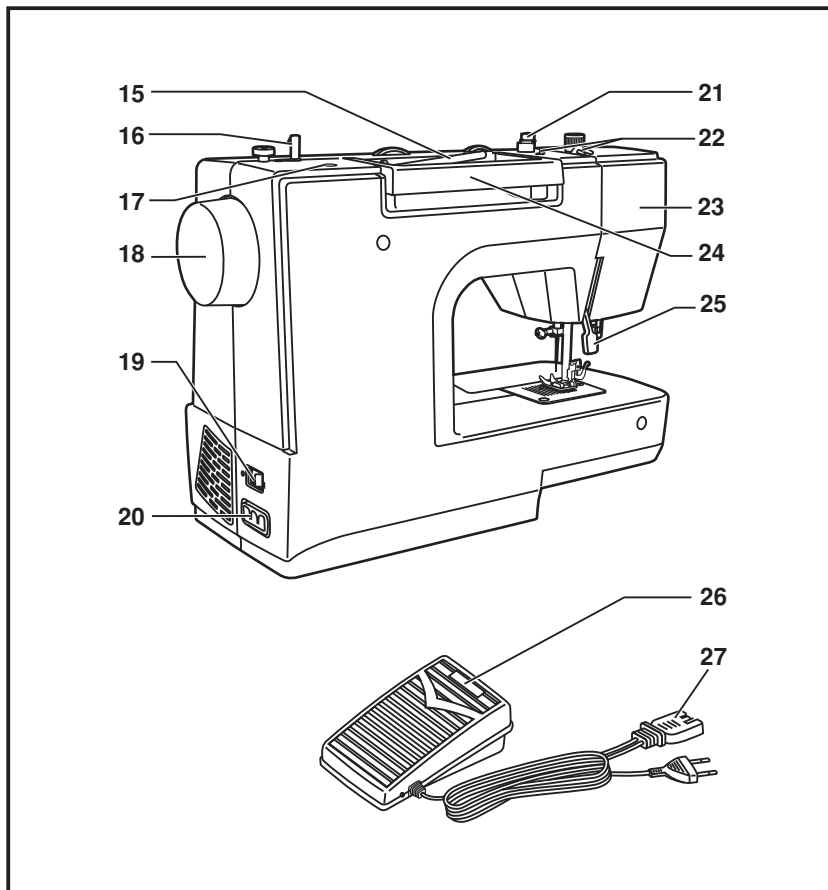

- 15. Horizontal spool pin
- 16. Bobbin winder spindle
- 17. Hole for second spool pin
- 18. Handwheel
- 19. Power switch
- 20. Main plug socket
- 21. Bobbin thread guide
- 22. Upper thread guide
- 23. Face plate
- 24. Handle
- 25. Presser foot lifter
- 26. Foot control
- 27. Power cord

Accessories are stored inside the accessory box.

Standard

1. Zig zag foot
2. Zipper foot
- 3-1. Buttonhole foot for sew&go 1 / 3
- 3-2. Buttonhole foot with slide for sew&go 5
4. Button-sew-on foot
5. Brush & seam ripper
6. Right seam guide
7. Needle set
8. Spool holder small & large
9. Bobbins
10. L Screwdriver
11. Oiler
12. Darning plate
13. Spool pin long V
14. Spool pin felt
15. Dust cover

Optional

16. Embroidery foot
17. Overlock foot
18. Hemmer foot
19. Cording foot
20. Blindstitch foot
21. Darning- / Embroidery foot
22. Gathering foot
23. Quilting foot
24. Walking foot
25. Twin needle

* Optional accessories are not supplied with this machine; they are however available as special accessories from your local dealer.

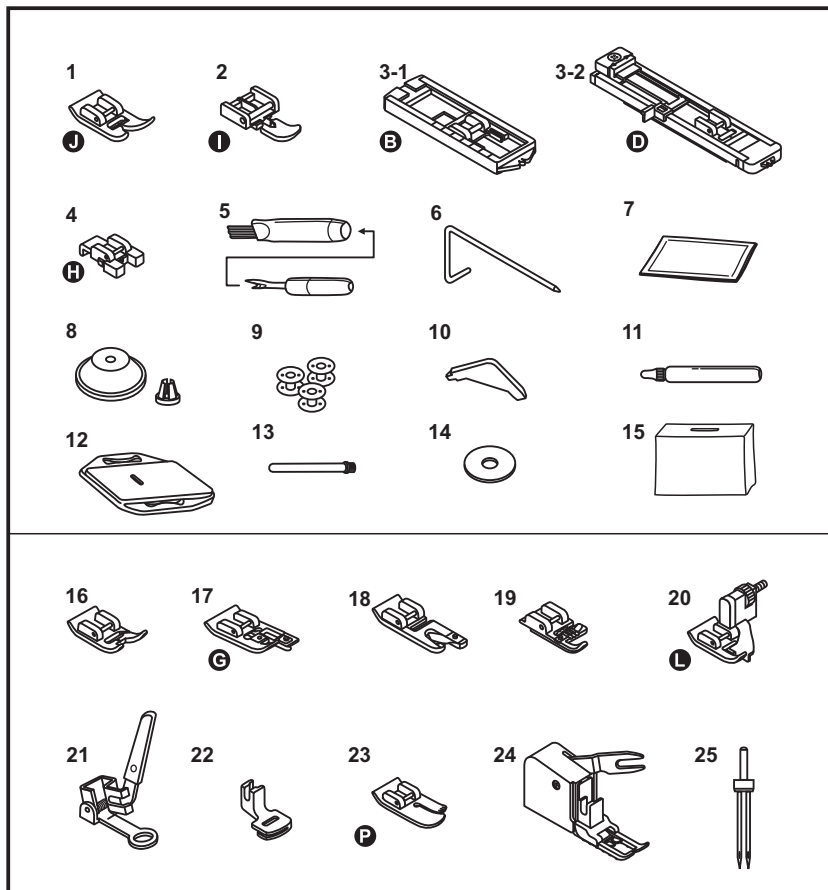

1. Keep the snap-in sewing table horizontal, and push it in the direction of the arrow.

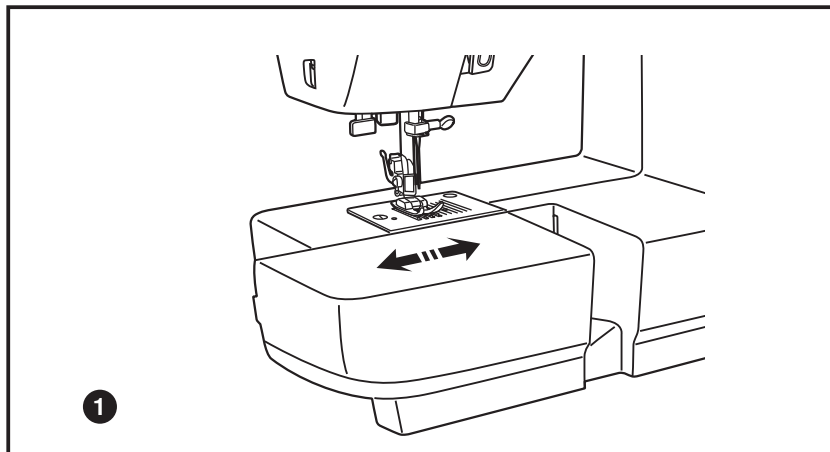

2. The inside of the snap-in sewing table can be utilized as an accessory box.

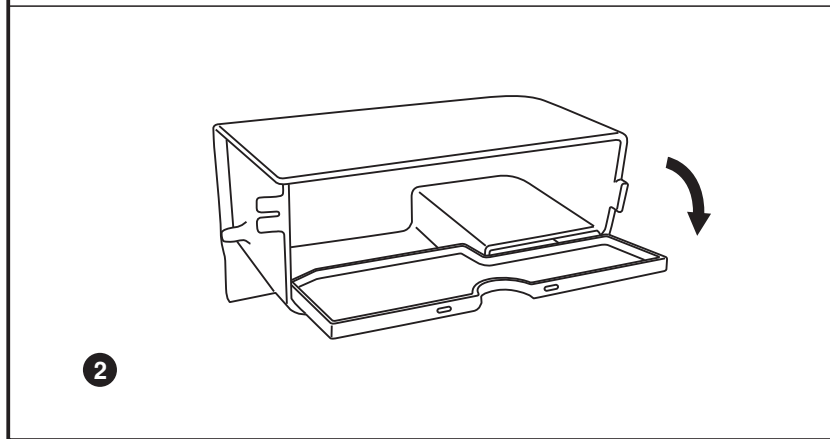

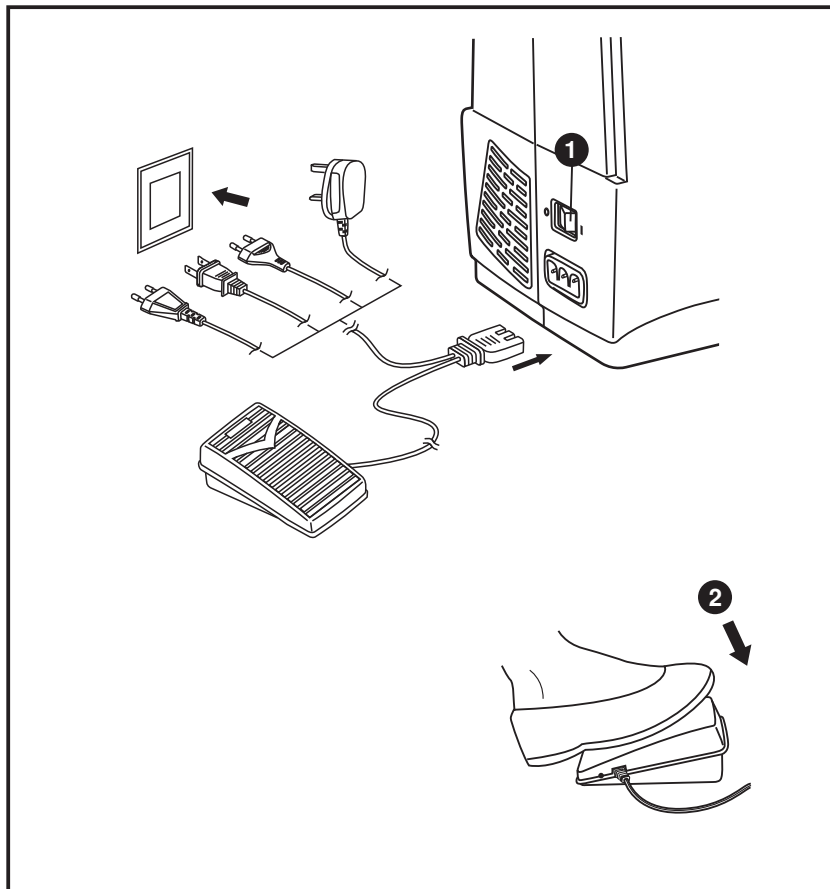

Attention:

Unplug power cord when machine is not in use. Consult a qualified electrician if in doubt of how to connect machine to power source.

Connect the machine to a power source as illustrated.

This appliance is equipped with a polarized plug which must be used with the appropriate polarized outlet.

Sewing light

1. Press main switch to "I" for power and light.

Foot control

2. Foot control pedal regulates the sewing speed.

IMPORTANT NOTICE

For appliance with a polarized plug (one blade is wider than the other). To reduce the risk of electric shock, this plug is intended to fit in a polarized outlet only one way. If it does not fit fully in the outlet, reverse the plug. If it still does not fit, contact a qualified electrician to install the proper outlet. Do not modify the plug in any way.

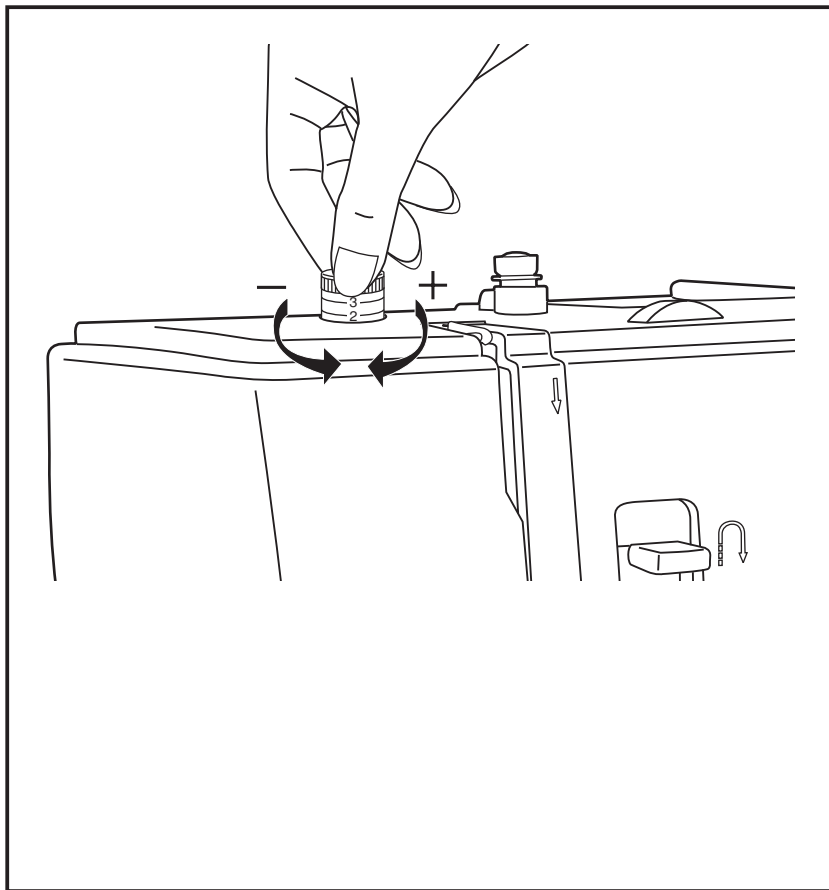

Standard presser foot pressure set at "2".

The presser foot pressure of the machine has been pre-set and no need for change is required unless sewing particular type of fabric (light-or-heavy weight).

If you do need to adjust the presser foot pressure, turn the presser adjusting screw by ones finger.

For sewing very thin fabric, loosen the pressure by turning the screw counterclockwise to move the screw upward and the pressure decreases. If you keep turning the screw, it could be taken out. By that time, just turn the screw clockwise, it can be locked back and readjust the pressure.

For heavy fabric, tighten the pressure by turning the screw clockwise to move the screw downward and the pressure increases. Once the screw cannot be turned any further, it has reached the bottom, please do not turn any more.

The presser foot lifter raises and lowers your presser foot. (A)

When sewing several layers or thick fabrics, the presser foot can be raised a second stage for easy positioning of the work. (B)

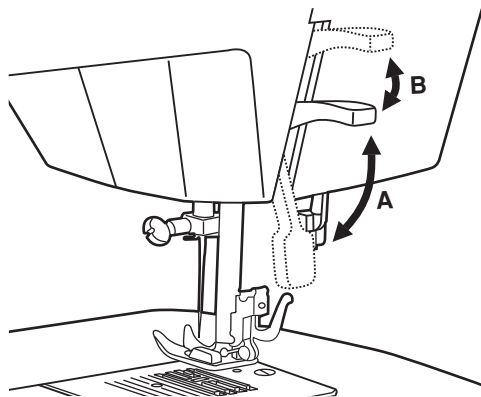

For certain types of work, (e.g. darning or free-hand embroidery), the darning plate must be used.

Install the darning plate as illustrated.

For normal sewing, remove the darning plate.

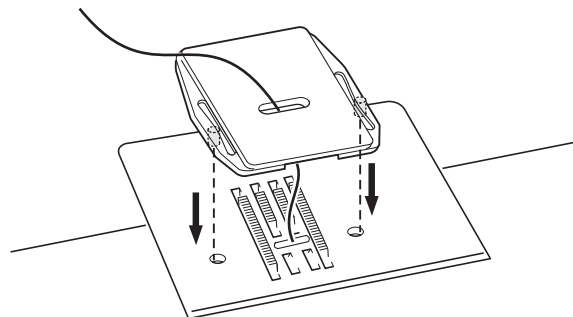

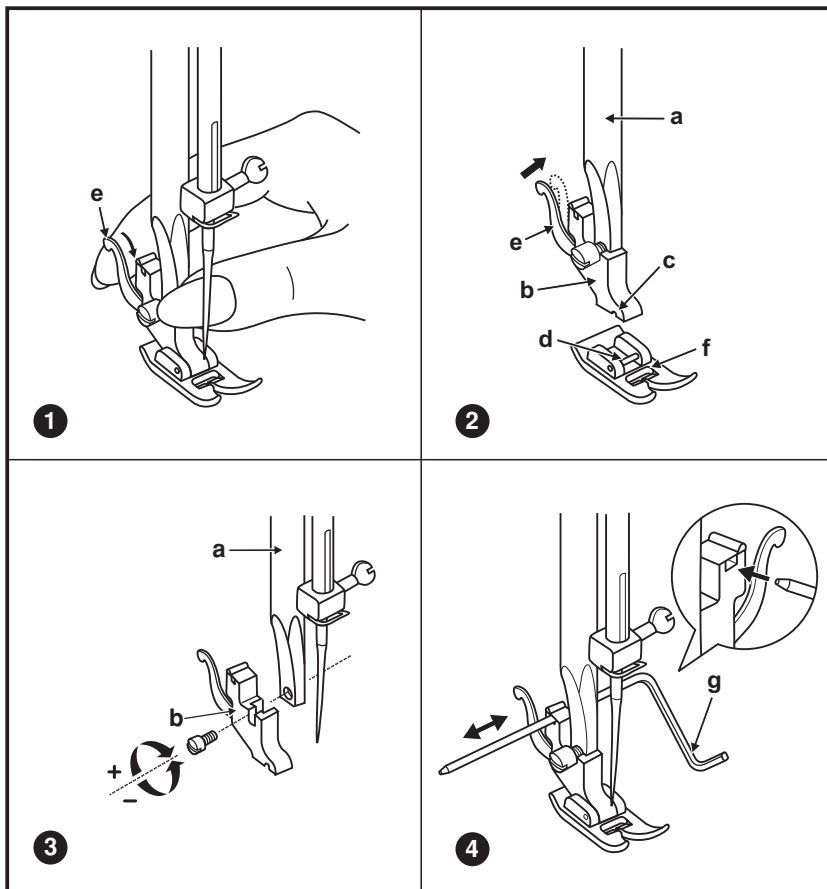

Attention:

Turn power switch to off ("O")!

1. Removing the presser foot

Raise the presser foot using the presser foot lifter.

Raise the lever (e) and the foot disengages.

2. Attaching the presser foot

Lower the presser foot holder (b) using the presser foot lifter, until the cut-out (c) is directly above the pin (d).

The presser foot (f) will engage automatically.

3. Removing and Attaching the presser foot shank

Raise the presser clamp (a) with the presser foot lifter.

Removing and Attaching the presser foot shank (b) as illustrated.

4. Attaching the Seam guide right

Attach the seam guide right (g) in the slot as illustrated. Adjust as needed for hems, pleats, quilting, etc.

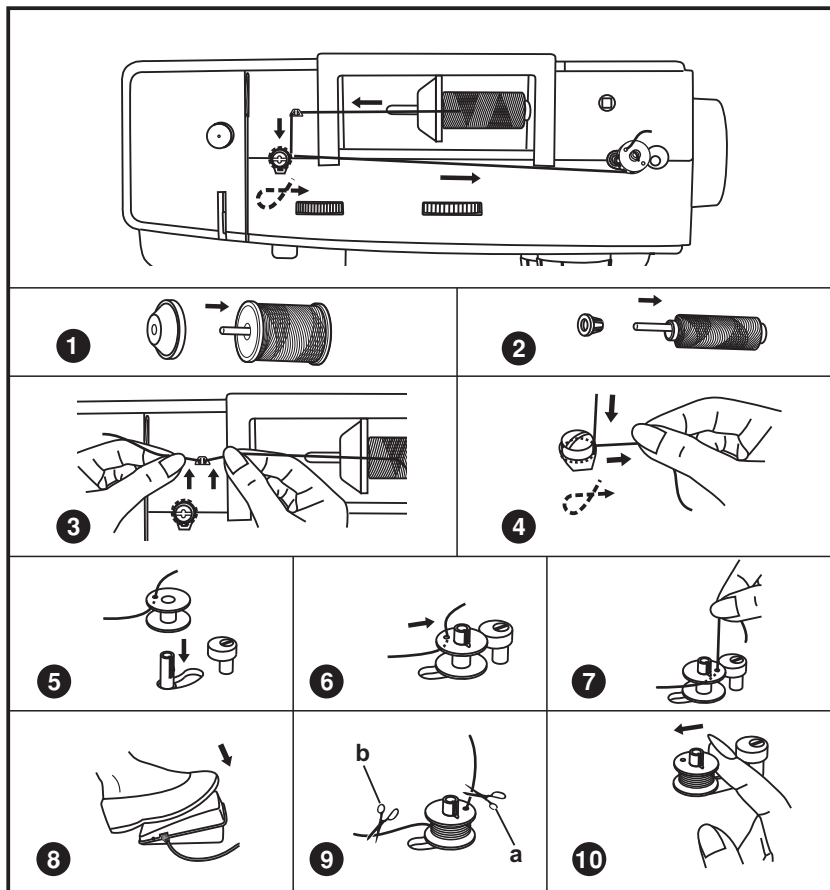

- 1/2. Place thread and corresponding spool holder onto spool pin.
3. Snap thread into thread guide.
4. Wind thread clockwise around bobbin winder tension discs.
5. Thread bobbin as illustrated and place on spindle.
6. Push bobbin winder spindle to right.
7. Hold thread end.
8. Step on foot control.
9. Release the pedal after a few turns. Release the thread and cut as close as possible to the bobbin (a). Press the pedal again. Once the spool is full, it rotates slowly. Release the pedal and cut thread (b).
10. Push bobbin winder spindle to left and remove.

Please Note:

When the bobbin winder spindle is in "bobbin winding" position, the machine will not sew and the hand wheel will not turn. To start sewing, push the bobbin winder spindle to the left (sewing position).

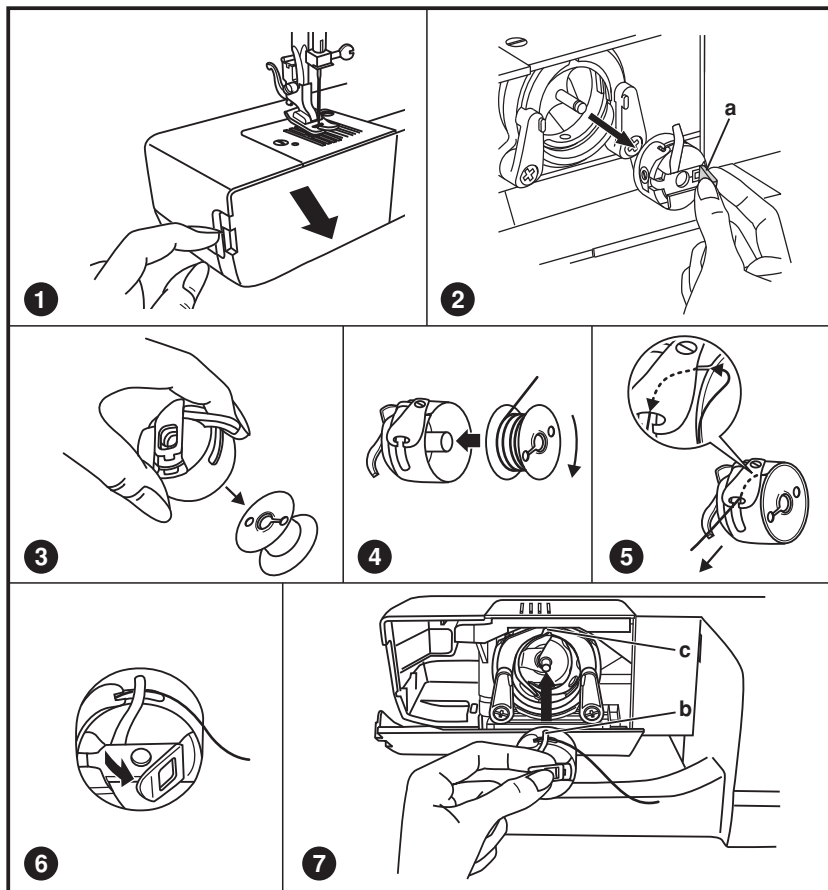

Attention:

Turn power switch to off ("O") before inserting or removing the bobbin.

When inserting or removing the bobbin, the needle must be fully raised.

1. Remove the sewing table, then open the hinged cover.
2. Pull the bobbin case by the hinged latch (a).
3. Remove the bobbin of the bobbin case.
4. Hold the bobbin case with one hand. Insert the bobbin so that the thread runs in a clockwise direction (arrow).
5. Pull the thread through the slit and under the finger. Leave a 6 inch tail of thread.
6. Hold the bobbin case by the hinged latch.
7. Make sure the bobbin case finger (b) fits into the notch (c) at the top of the race as shown.

Note:

If the bobbin case is not properly placed back into the machine, it will fall out of the shuttle immediately after starting to sew.

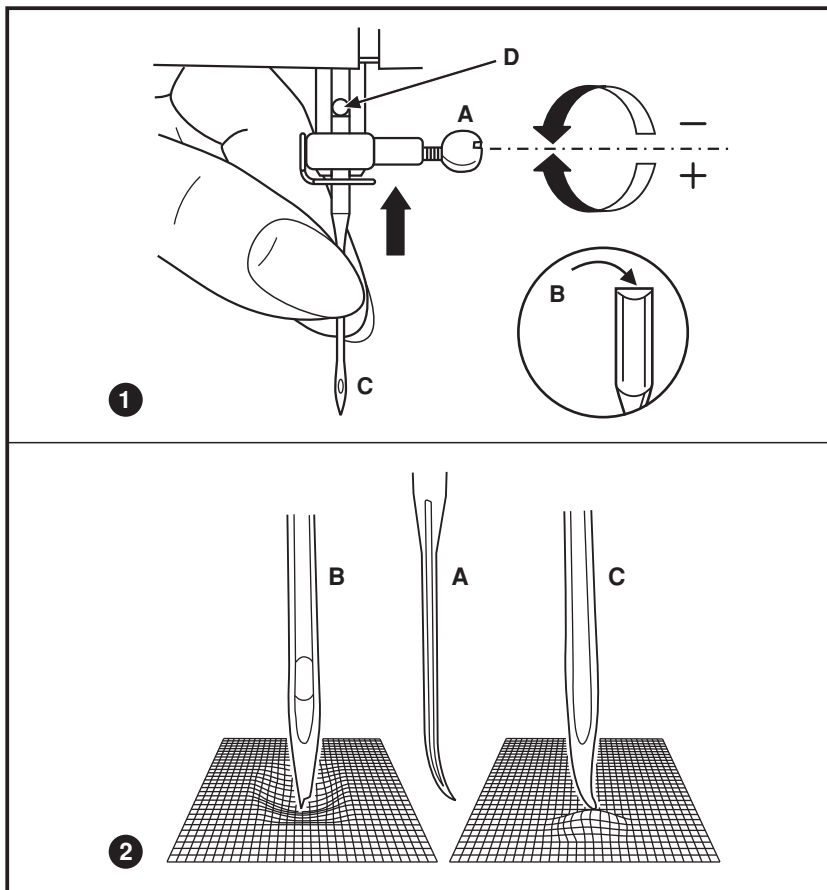

Attention:

Turn power switch to off ("O") before inserting or removing the needle.

1. Change the needle regularly, especially if it is showing signs of wear and causing problems.

Insert the needle as illustrated as follows:

- A. Loosen the needle clamp screw and tighten again after inserting the new needle.
- B. The flat side of the shaft should be towards the back.
- C/D. Insert the needle as far up as it will go.

2. Needles must be in perfect condition.

Problems can occur with:

- A. Bent needles
- B. Damaged points
- C. Blunt needles

This is a simple operation but it is important to carry out correctly as by not doing so several sewing problems could result.

1. Start by raising the needle to its highest point, and continue turning the handwheel counterclockwise until the needle just slightly begins to descend. Raise the presser foot to release the tension discs.

Note: For safety, it is strongly suggested you turn off the power before threading.

2. Lift up the spool pin. Place the spool of thread on the holder with the thread coming off the spool as shown. For small thread spools, place small side of spool holder next to spool.

3. Draw thread from spool through the upper thread guide.

4. Pulling thread through pre-tension spring as illustrated.

5. Thread tension module by leading thread down right channel and up left channel. During this process it is helpful to hold the thread between the spool and thread guide.

6. At the top of this movement pass thread from right to left through the slotted eye of the take-up lever and then downwards again.

7. Now pass thread behind the thin wire needle clamp guide and then down to the needle which should be threaded from front to back.

8. Pull about 6-8 inches of thread to the rear beyond the needle eye. Trim thread to length with built-in thread cutter.

Note:

If your sewing machine is equipped with the factory installed optional automatic needle threader, instructions for use can be found on next page.

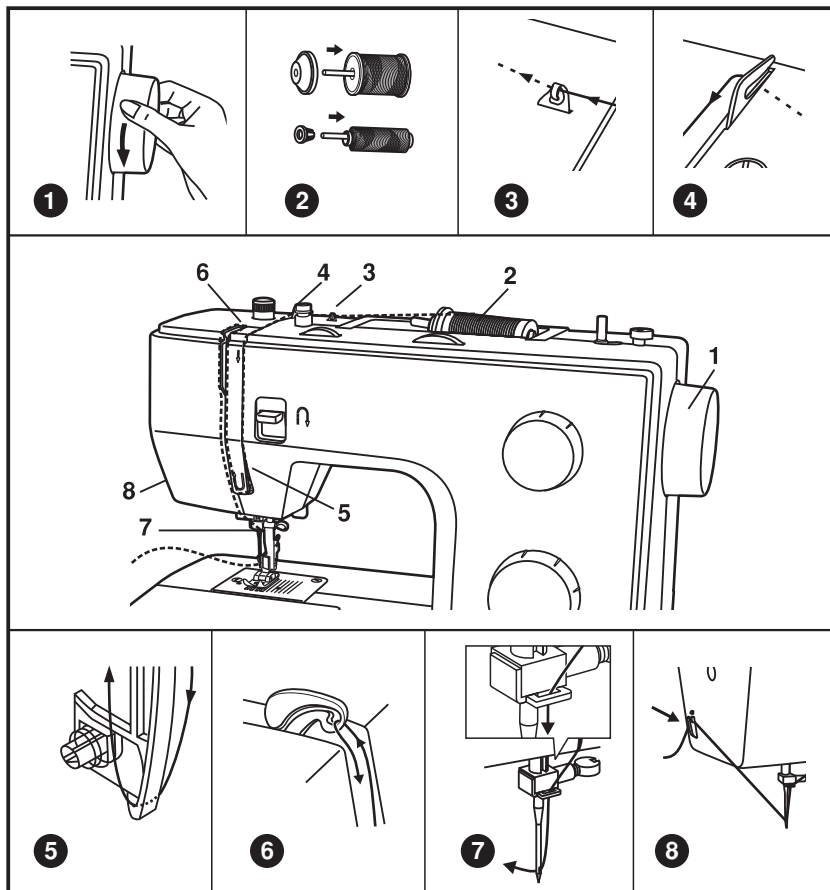

Attention:

Turn power switch to off ("O")!

- Raise the needle to its highest position.
- Press lever (A) down as far as it will go.
- The threader automatically swings to the threading position (B).
- Pass thread around thread guide (C).
- Pass the thread in front of the needle around the hook (D) from bottom to top.
- Release lever (A).
- Pull the thread through the needle eye.

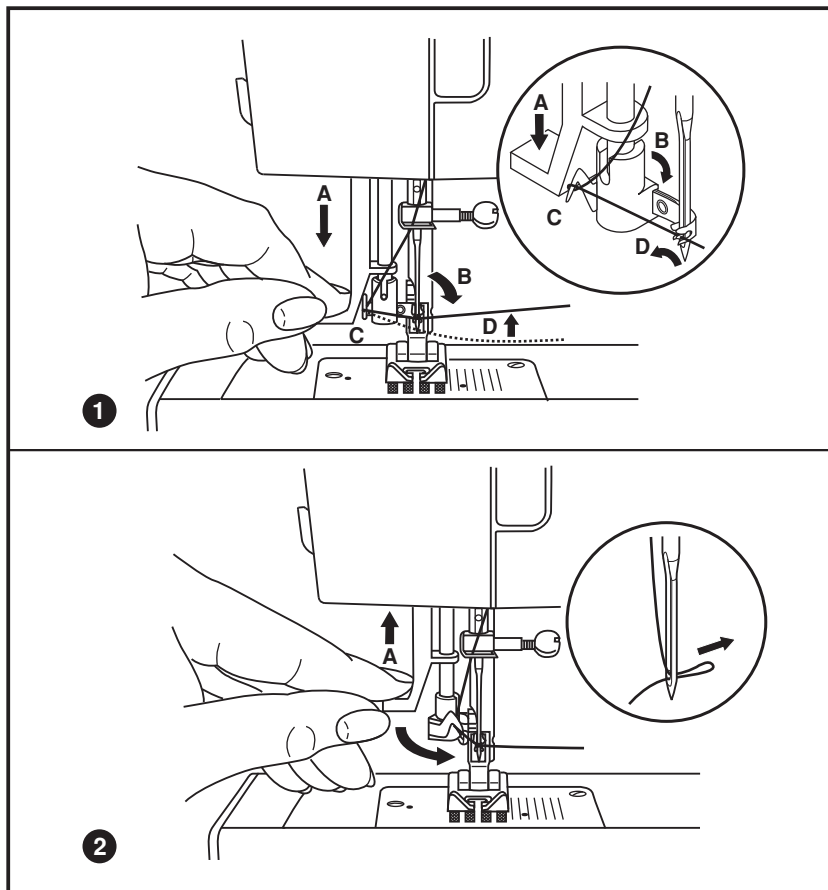

Upper thread tension

Basic upper thread tension setting: "4".

To increase the tension, turn the dial to the next higher number. To reduce the tension, turn the dial to the next lower number.

- A. Normal thread tension
- B. Upper thread tension too loose
- C. Upper thread tension too tight

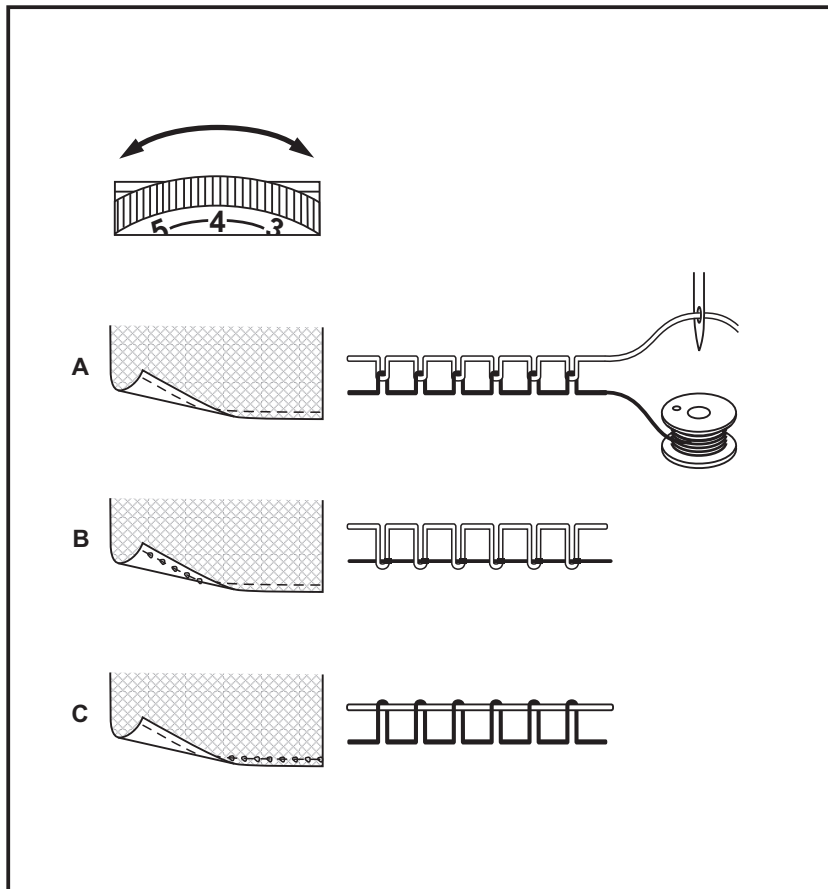

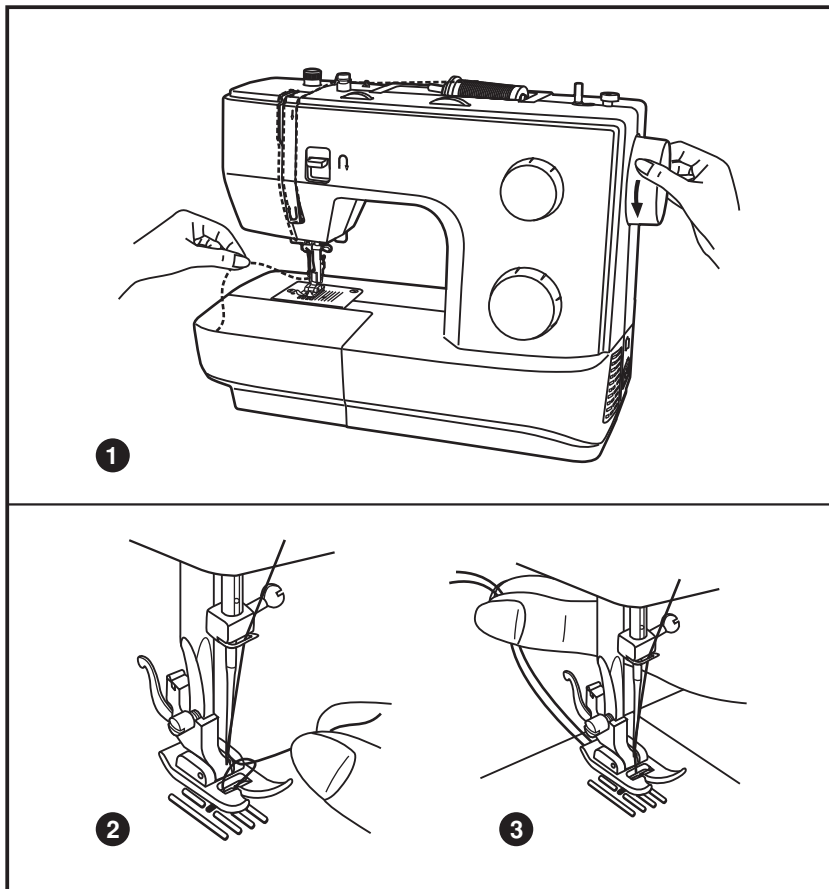

1. Hold the upper thread with the left hand. Turn the handwheel towards you (counterclockwise) lowering, and then raising the needle.

Note:

If it is difficult to raise the bobbin thread, check to make sure the thread is not trapped by the hinged cover or the sewing table.

2. Gently pull on the upper thread to bring the bobbin thread up through the stitch plate hole.
3. Lay both threads to the back under the presser foot.

NEEDLE, FABRIC, THREAD SELECTION GUIDE

Needle size	Fabrics	Thread
9-11(65-75)	Lightweight fabrics-thin cottons, voile, serge, silk, muslin, Qiana, interlocks, cotton knits, tricot, jerseys, crepes, woven polyester, shirt & blouse fabrics.	Light-duty thread in cotton, nylon or polyester.
12(80)	Medium weight fabrics-cotton, satin, kettlecloth, sailcloth, double knits, lightweight woollens.	Most threads sold are medium size and suitable for these fabrics and needle sizes. Use polyester threads on synthetic materials and cotton on natural woven fabrics for best results.
14(90)	Medium weight fabrics-cotton duck, woolen, heavier knits, terrycloth, denims.	Always use the same thread on top and bottom.
16(100)	Heavyweight fabrics-canvas, woollens, outdoor tent and quilted fabrics, denims, upholstery material (light to medium).	Heavy duty thread, carpet thread. (Use heavy foot pressure-higher indication numbers.)
18(110)	Heavy woollens, overcoat fabrics, upholstery fabrics, some leathers and vinyls.	

IMPORTANT: Match needle size to thread size and weight of fabric

NEEDLE, FABRIC SELECTION

Needles	Explanation	Type of fabric
HA×1 15×1	Standard sharp needles. Sizes range thin to large. 9 (65) to 18(110)	Natural woven fabrics-wool, cotton, silk, etc. Qiana. Not recommended for double knits.
15×1/ 705H(SUK)	Semi-ball point needle, scarfed. 9(65) to 18(110)	Natural and synthetic woven fabrics, polyester blends. Knits-polyesters, interlocks, tricot, single and double knits. Can be used instead of 15×1 for sewing all fabrics.
15×1/ 705H(SUK)	Full ball point needle 9(65) to 18(110)	Sweater knits, Lycra, swimsuit fabric, elastic.
130 PCL	Leather needles. 12(80) to 18(110)	Leather, vinyl, upholstery. (Leaves smaller hole than standard large needle.)

Note:

1. *Twin needles, can be purchased for utility and decorative work.*
2. *When sewing with twin needles, the stitch width dial should be set at less than "3". (model sew&go 5)*
3. *European needles show sizes 65, 70, 80 etc. American and Japanese needles show size 9, 11, 12 etc.*
4. *Replace needle often (approximately every other garment) and / or at first thread breakage or skipped stitches.*
5. *Use a stabilizer for fine or stretchy fabrics.*

1

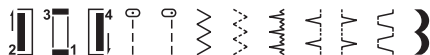
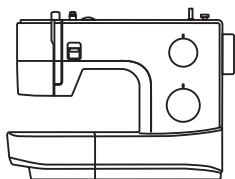

3

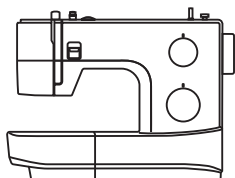

5

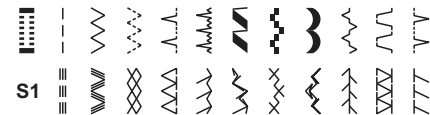
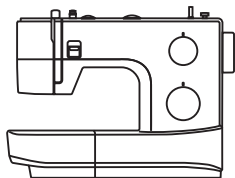

Raise the needle to its highest position.
Then turn the stitch selector dial to set the desired stitch pattern at the setting mark.

For **straight stitch**, select pattern "0" or "1" with the stitch selector dial. Adjust the stitch length with the stitch length dial.

For **zigzag stitch**, select pattern "2" with the stitch selector dial. Adjust the stitch length and stitch width according to the fabric being used.

To obtain the other patterns, turn the stitch length dial to "S1", select the pattern desired with stitch selector dial, and adjust the stitch width with the stitch width dial (model sew&go 5)

Please consult the following stitch patterns chart.

Stitch width dial (sew&go 5)

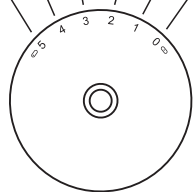
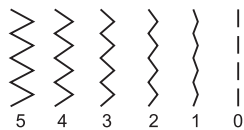

1

For 2-dial model (sew&go 1/3)

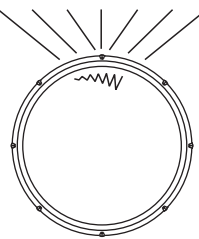

Stitch length dial

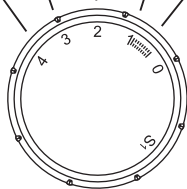
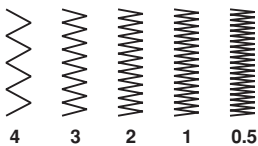

2

Stitch length dial

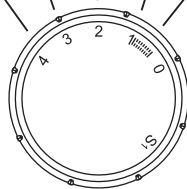
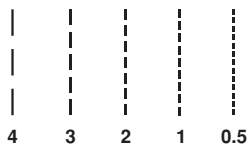

3

1. Function of stitch width dial

The maximum zigzag stitch width for zigzag stitching is 5mm; however, the width can be reduced on any patterns. The width increases as you move stitch width dial from "0" - "5".

The Stitch width dial is also the control for the straight stitch infinite needle position. "0" position is center and "5" is full left needle position. (model sew&go 5)

2. Function of stitch length dial while zig-zag stitching

Set the stitch selector dial to zig-zag.

The density of zig-zag stitches increase as the setting of stitch length dial approaches "0". Neat zig-zag stitches are usually achieved at "2.5" or below.

3. Function of stitch length dial for straight stitching

For straight stitch sewing, turn the stitch selector dial to the straight stitch setting. Turn the stitch length dial, and the length of the individual stitches will decrease as the dial approaches "0". The length of the individual stitches will increase as the dial approaches "4".

Generally speaking, use a longer stitch length when sewing heavier weight fabrics or when using a thicker needle or thread. Use a shorter stitch length when sewing lighter weight fabrics or when using a finer needle or thread.

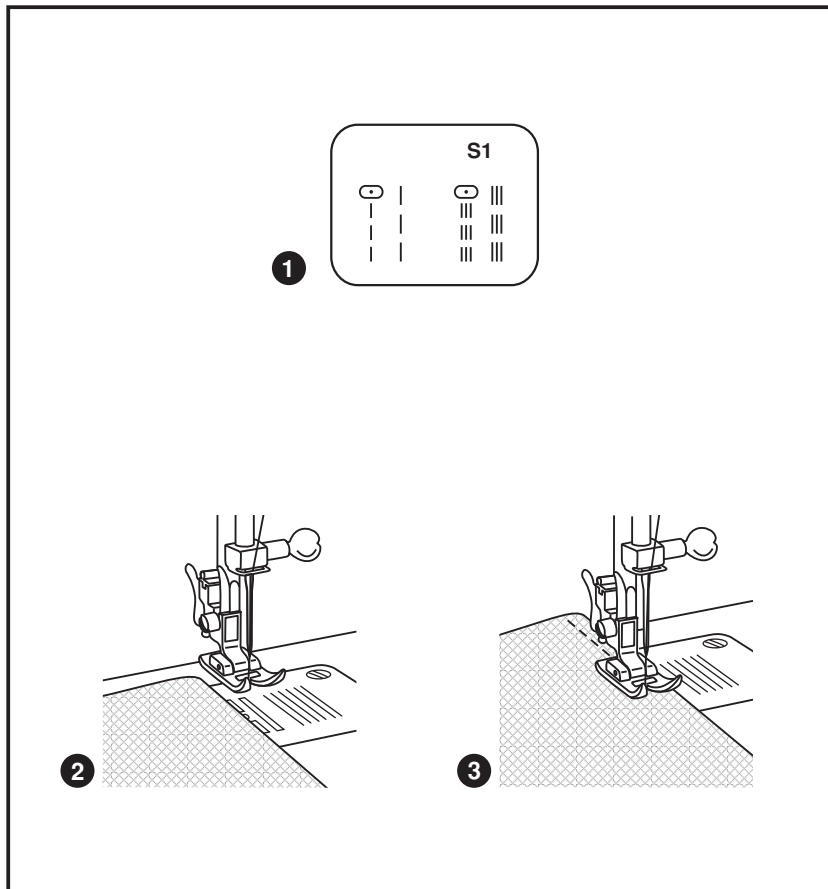

1. To begin sewing, set the machine for straight stitch.

2. Place the fabric under the presser foot with the fabric edge lined up with the desired seam guide line on the stitch plate.

3. Lower the presser foot lifter, and then step on the foot controller to start sewing.

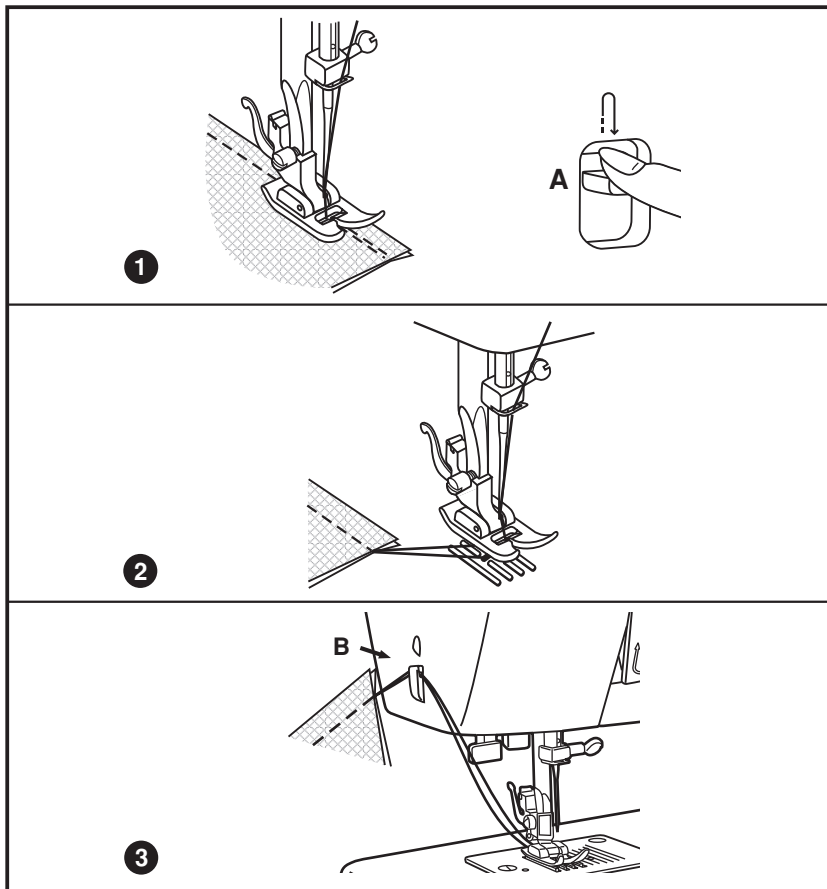

Beginning the seam

Place fabric approximately 1cm (1/2") inward from the outer edge under the presser foot. Press the reverse sewing lever (A) while sewing backwards up to the fabric edge.

1. End of seam

At the end of seam, press down the reverse sewing lever (A). Sew a few reverse stitches. Release the lever and the machine will sew forwards again.

2. Removing the work

Turn the handwheel towards to bring the thread take up lever to its highest position, raise the presser foot and remove the work towards the back.

3. Cutting the thread

Cut both threads with the thread cutter (B) located on the left rear side of the face plate.

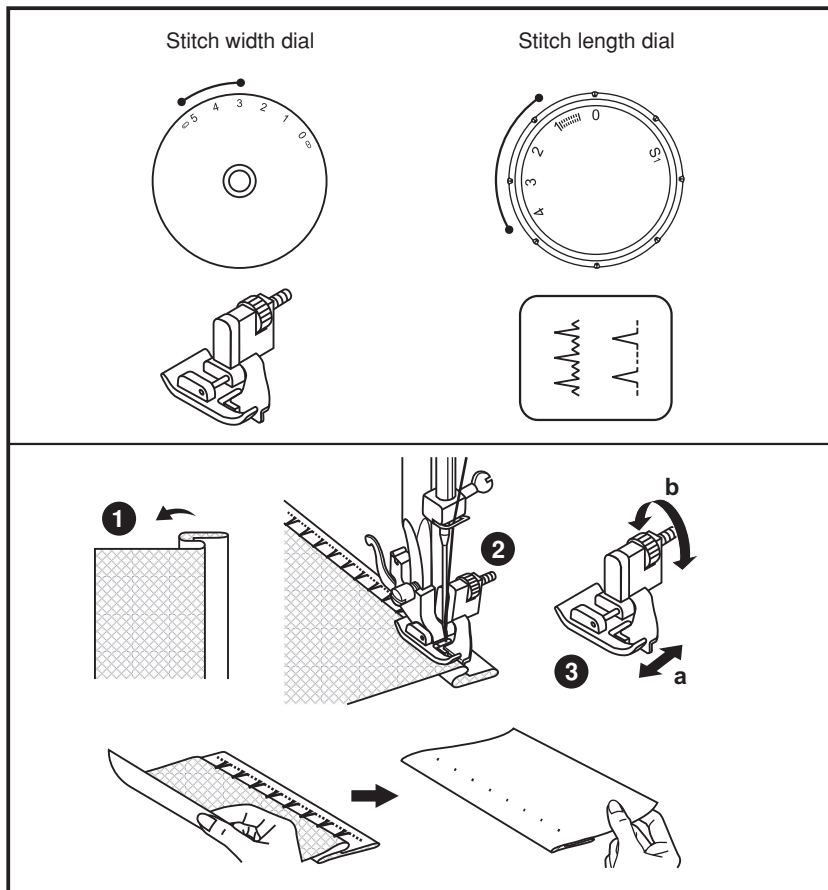

* The blindstitch foot is an optional accessory and is not supplied with your machine.

For hems, curtains, trousers, skirts, etc.

..A..A.. Blind hem for stretch fabrics.

..A..A.. Blind hem/ lingerie for firm fabrics.

Set the machine as illustrated.

Note:

It takes practice to sew blind hems. Always make a sewing test first.

1. Fold the fabric as illustrated with the wrong side uppermost.
 2. Place the fabric under the foot. Turn the handwheel forwards by hand until the needle swings fully to the left. It should just pierce the fold of the fabric. If it does not, adjust the stitch width accordingly.
 3. Adjust the guide (a) by turning the knob (b) so that the guide just rests against the fold.
- Sew slowly, by pressing the foot control lightly guiding the fabric along the edge of the guide.

Please Note:

No "S1" marking is shown on the stitch length dial by model sew&go 1.

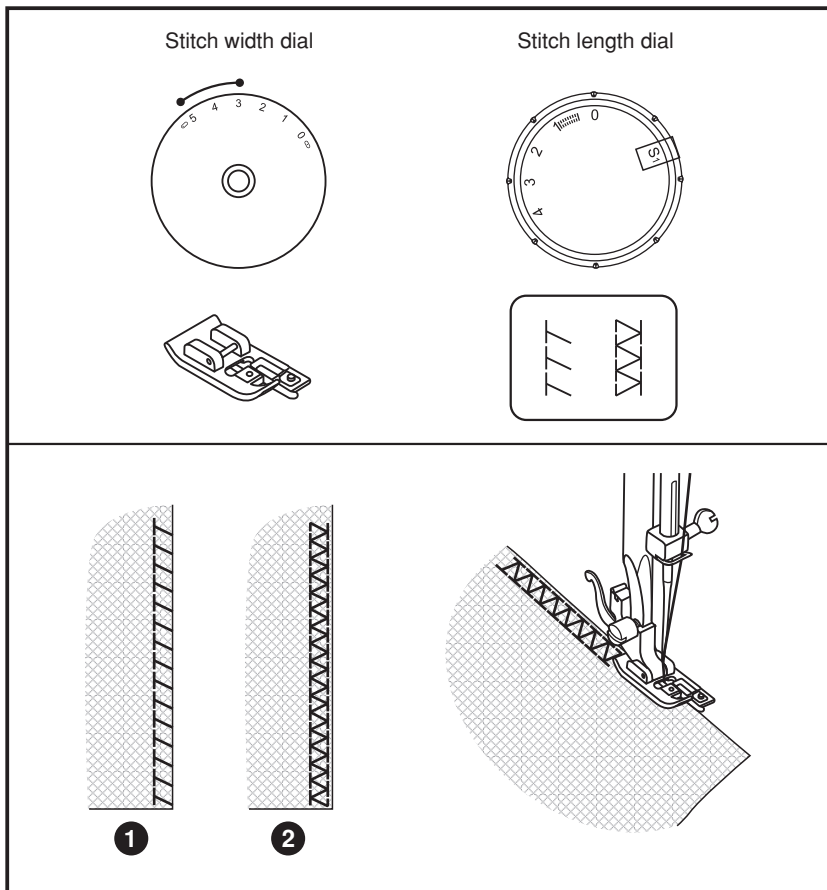

* The overlock foot is an optional accessory and is not supplied with your machine.

Seams, neatening, visible hems.

Turn stitch length dial to "S1".

The stitch width can be adjusted to suit the fabric.

Stretch overlock:

For fine knits, jerseys, neck edges, ribbing. (1)

Double overlock stitch:

For fine knits, handknits, seams. (2)

All overlock stitches are suitable for sewing and neatening edges and visible seams in one operation.

When neatening, the needle should just go over the edge of the fabric.

Attention:

Use new needles or ball point needles or stretch needle!

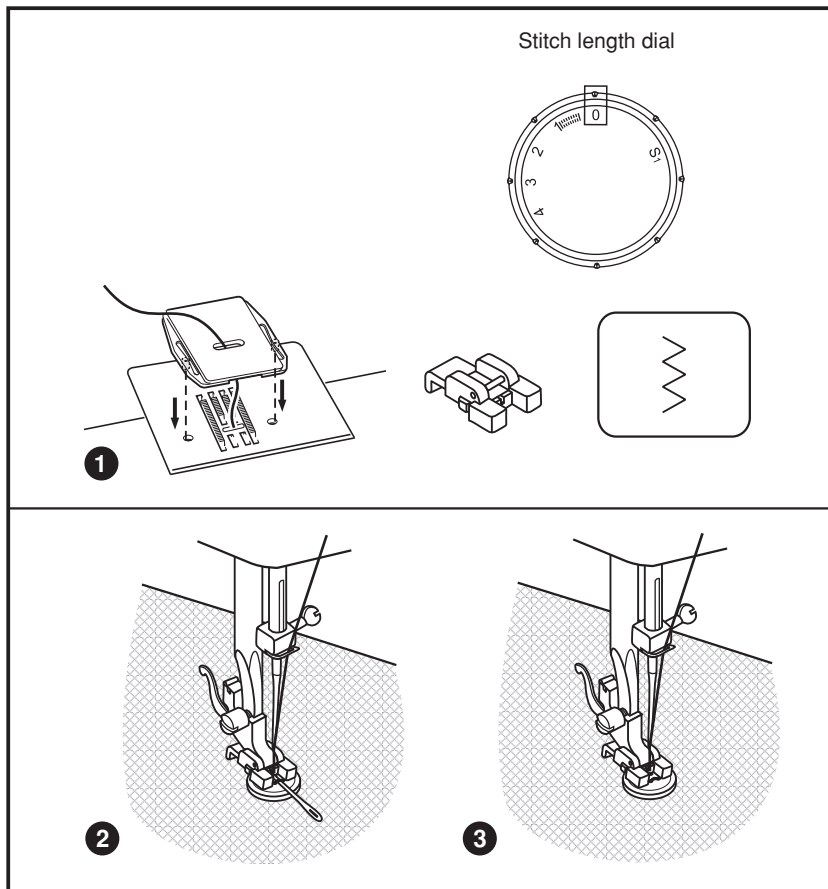

1. Install the darning plate.

Change presser foot to button-sew-on foot.

Position the work under the foot.

Place the button on the marked position and lower the foot.

- Set the stitch selector dial on " " and sew a few securing stitches.
- Select zig-zag stitch with a stitch width according to the distance between the two holes of the button. Turn the handwheel to check if the needle goes into the right and left hole of the button without any obstruction. Slowly sew on the button with about 10 stitches.
- Select stitch " " and finish the sewing on button by sewing a few securing stitches.

2. If a shank is required, place a darning needle on top of the button and sew.

3. For buttons with 4 holes, sew through the front two holes first, push work forward and then sew through the back two holes as described.

Please Note:

No "S1" marking is shown on the stitch length dial by model sew&go 1.

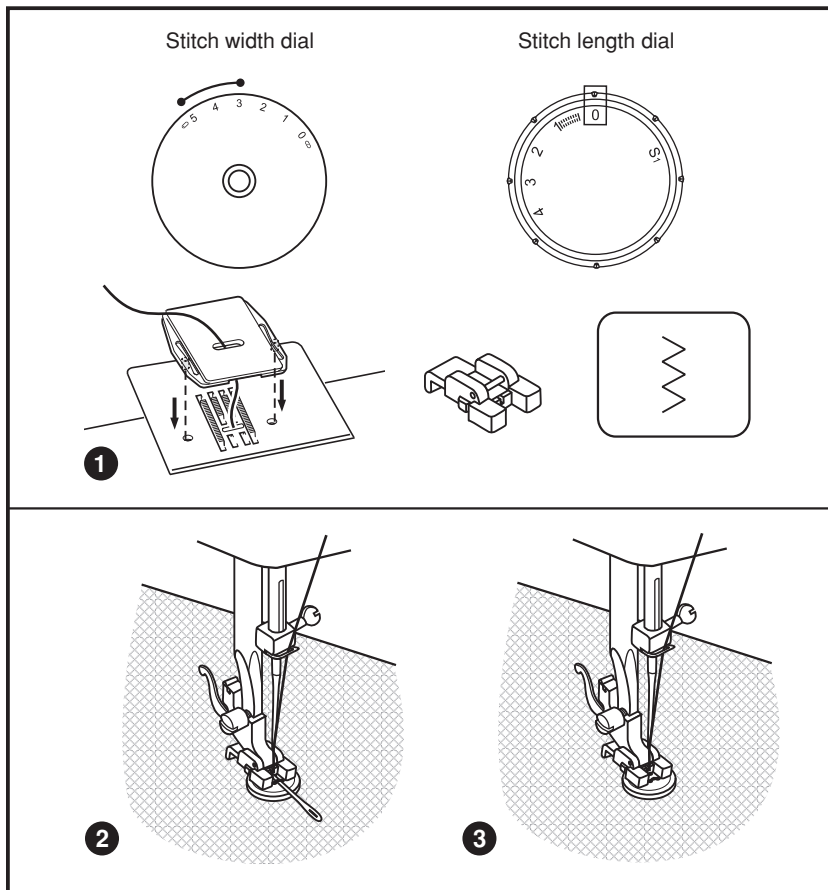

1. Install the darning plate.

Change presser foot to button-sew-on foot.

Position the work under the foot.

Place the button on the marked position and lower the foot.

- Set the stitch selector dial on " | | " and sew a few securing stitches.
- Set the stitch selector dial on zig-zag stitch " ~ " and adjust the stitch width to 3 - 5 according to the distance between the two holes of the button. Turn the handwheel to check if the needle goes into the right and left hole of the button without any obstruction. Slowly sew on the button with about 10 stitches.
- Select stitch " | | " and finish the sewing on button with sewing a few securing stitches.

2. If a shank is required, place a darning needle on top of the button and sew.

3. For buttons with 4 holes, sew through the front two holes first, push work forward and then sew through the back two holes as described.

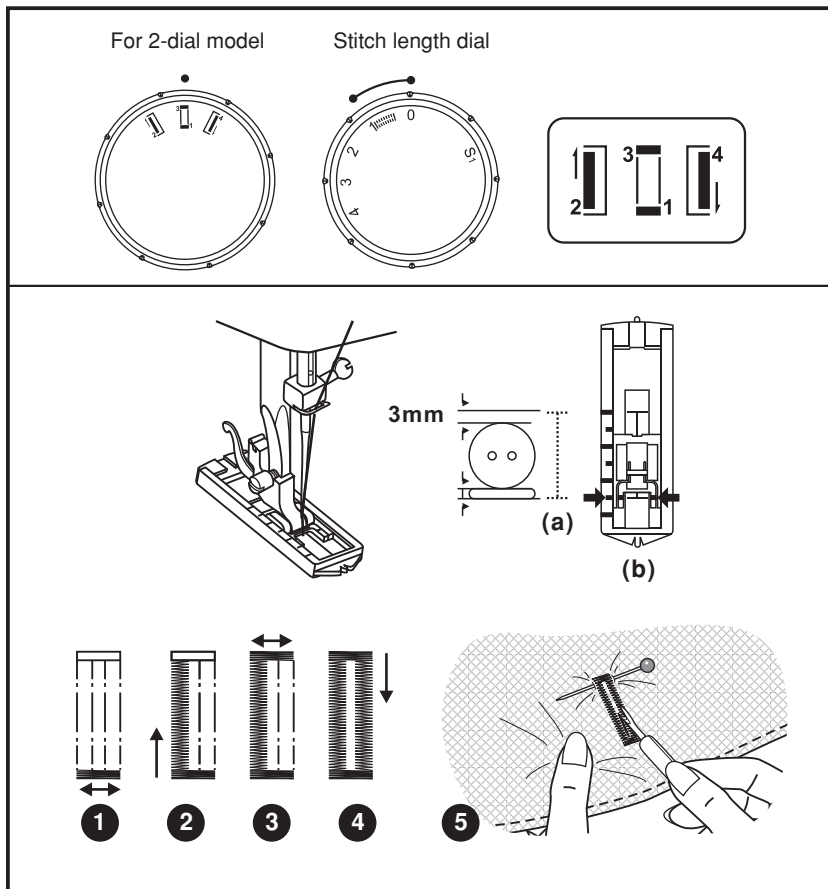

Preparation

- Take off the zig zag foot and attach the buttonhole foot.
- Measure diameter and thickness of button and add 3 mm (1/8") for bar tacks; mark buttonhole size on fabric. (a)
- Place fabric under the foot, so that mark on the buttonhole foot lines up with the marking on the fabric. Lower the foot, so that the center line of the fabric buttonhole comes to the center of the foot hole. (b)

Adjust the stitch length dial in the " " range to set stitch density.

Note: density varies according to the fabric. Always sew a test buttonhole.

1. Select " 3 " on stitch selector dial and sew a few bar tacks.
2. Select " 1 " and sew the left side of the buttonhole.
3. Select the same pattern as in " 3 " and sew the back bar tack.
4. Select " 2 " and sew the right side of the buttonhole.
5. Use seam ripper and cut buttonhole open from both ends towards the middle.

Tips :

- Slightly reduce upper thread tension to produce better results.
- Use a stabilizer for fine or stretchy fabrics.

Please Note:

No "S1" marking is shown on the stitch length dial by model sew&go 1.

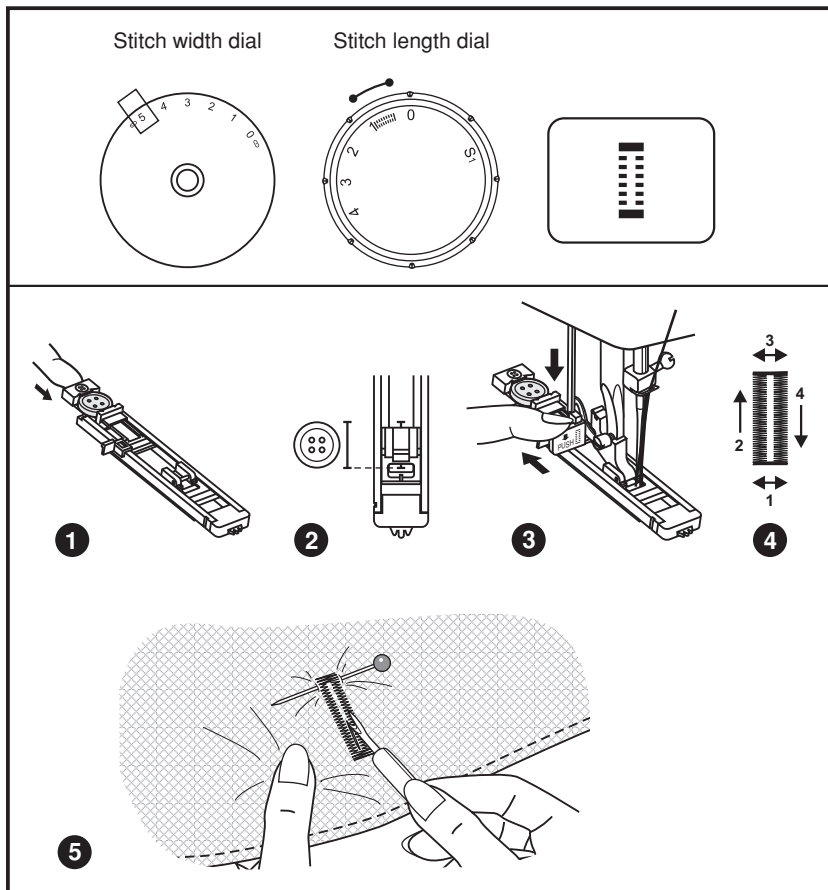

It is suggested that you always sew a test buttonhole on a sample of your fabric. The fabric should be stabilized especially when sewing thin and stretch fabrics.

Making a Buttonhole

Using tailor's chalk, mark the position of the buttonhole on the fabric.

Attach the buttonhole foot and set the stitch selector dial to "█".

Set stitch length dial to "█". Set the stitch width at "5". The width however may need to be adjusted according to the project, sew a test first to determine this.

1. Open the button plate and insert the button.
2. Lower the presser foot aligning the marks on foot with the marks on the fabric. (The front bar tack will be sewn first.)
3. Lower the buttonhole lever and gently push it back. While lightly holding the upper thread, start the machine.
4. Buttonhole stitching is done in the order. Stop the machine when the buttonhole cycle has completed.
5. Use seam ripper and cut buttonhole open from both ends towards the middle.

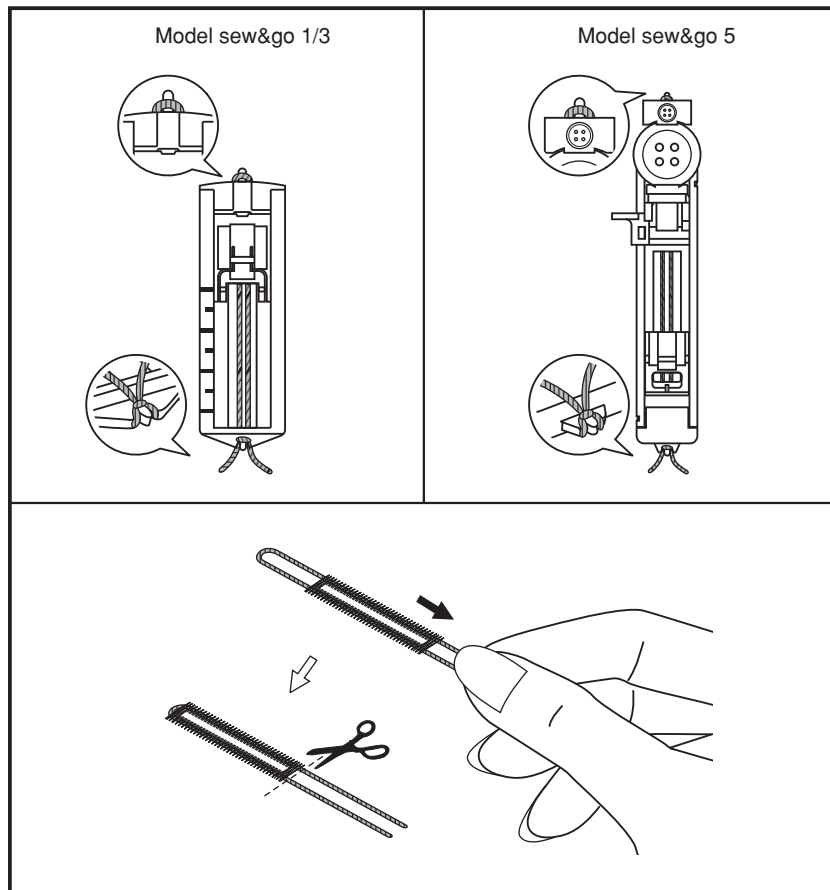

When sewing buttonholes on stretch fabric, hook heavy thread or cord under the buttonhole foot as shown.

1. Attach the buttonhole foot and hook the gimp thread onto the back of the presser foot.
2. Bring the two gimp thread ends to the front of the foot and insert them into the grooves, then temporarily tie them there.
3. Lower the presser foot and start sewing.
4. Set the stitch width to match the diameter of the gimp thread.
5. Once sewing is completed, pull the gimp thread gently to remove any slack, then trim off any excess.

Set the machine as illustrated.

1. Place the right sides of the fabric together. Sew a seam in the width of the seam allowance from the right edge to the zipper bottom stop position. Sew a few stitches in reverse to lock. Increase the stitch length to maximum, set the tension below 2, and baste the remaining length of the fabric.
2. Press open the seam allowance. Place the zipper face down on the seam allowance with the teeth against the seam line. Baste the zipper tape in place.
3. The zipper foot can be inserted right or left, depending on which side of the foot you are going to sew.
4. Stitch around the zipper on the right side of the fabric, then remove the basting.

Please Note:

No "S1" marking is shown on the stitch length dial by model sew&go 1.

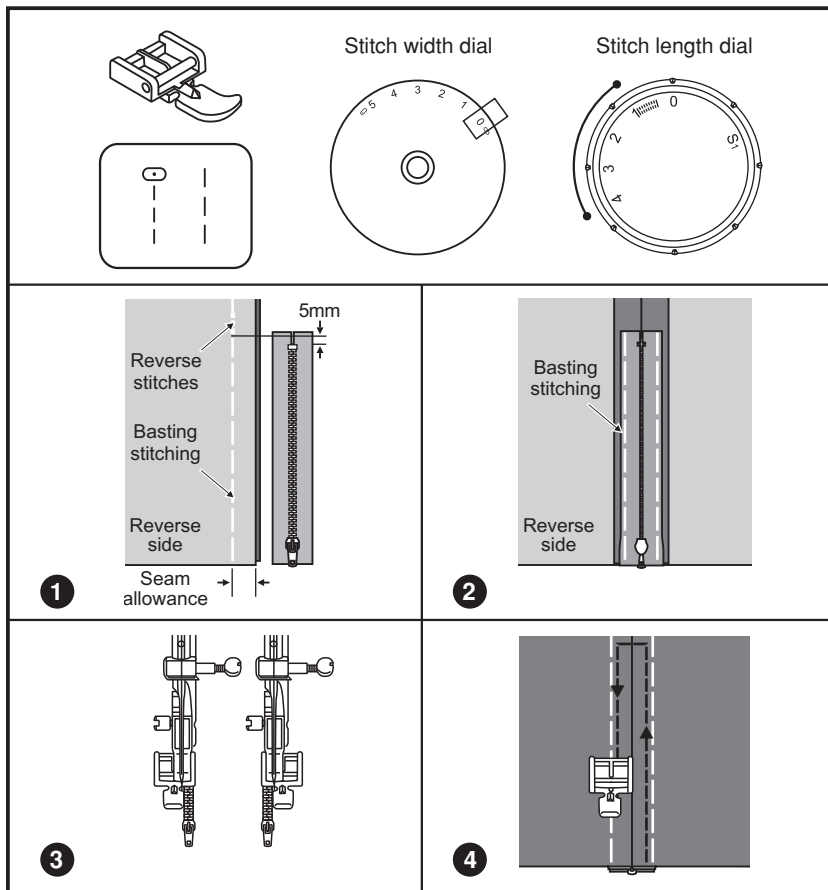

* The hemmer foot is an optional accessory and is not supplied with your machine.

For hems in fine or sheer fabrics.

Set the machine as illustrated.

1. Neaten the edge of the fabric. At the beginning of the hem, turn under the edge twice by about 3mm (1/8") and sew 4-5 stitches to secure. Pull the thread slightly towards the back. Insert the needle into the fabric, raise the presser foot and guide the fold into the scroll on the foot.

2. Gently pull the fabric edge towards you and lower the presser foot. Begin sewing, guiding the fabric into the scroll by holding it upright and slightly to the left.

Please Note:

No "S1" marking is shown on the stitch length dial by model sew&go 1.

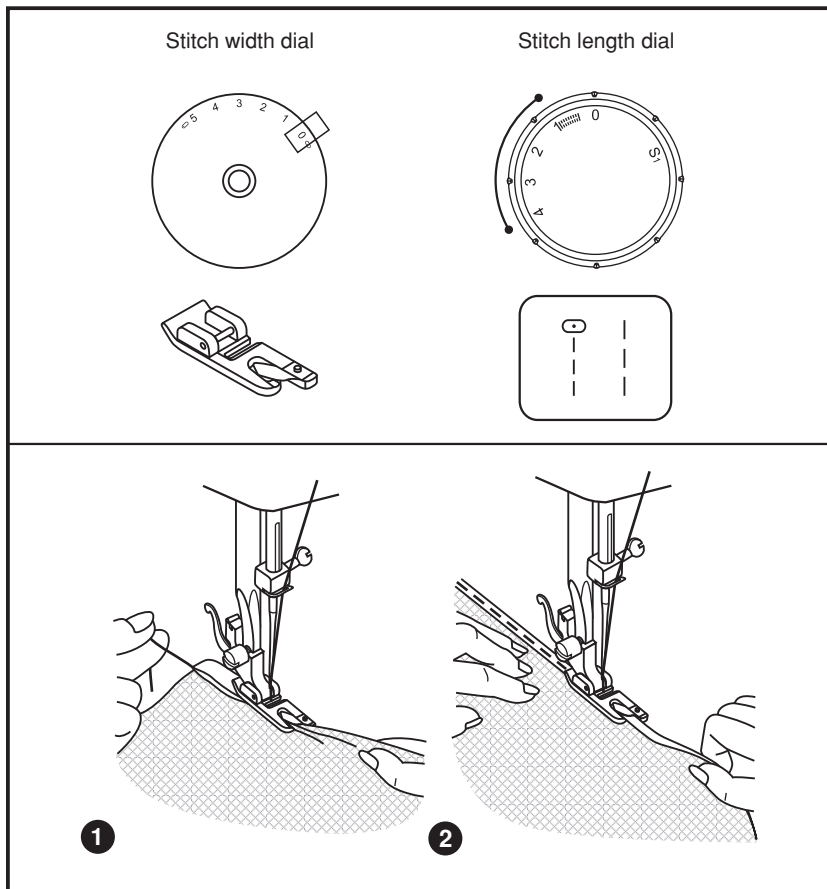

Stitch width dial

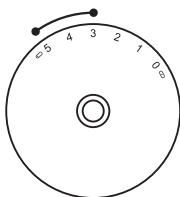

Stitch length dial

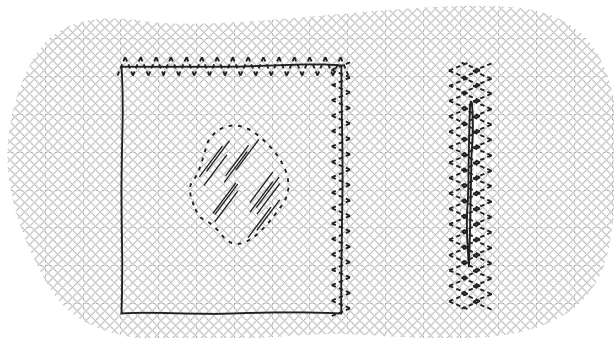
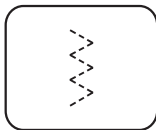
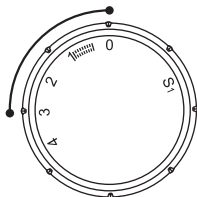

1

2

Sewing on lace and elastic, darning, mending, reinforcing edges.

Set the machine as illustrated.

Place patch in position.

1. The stitch length can be shortened to produce very close stitches.
2. When mending tears, it is advisable to use a piece of backing fabric to reinforce. The stitch density can be varied by adjusting the stitch length. First sew over the center and then overlap on both sides. Depending on the type of fabric and damage, sew between 3 and 5 rows.

Please Note:

No "S1" marking is shown on the stitch length dial by model sew&go 1.

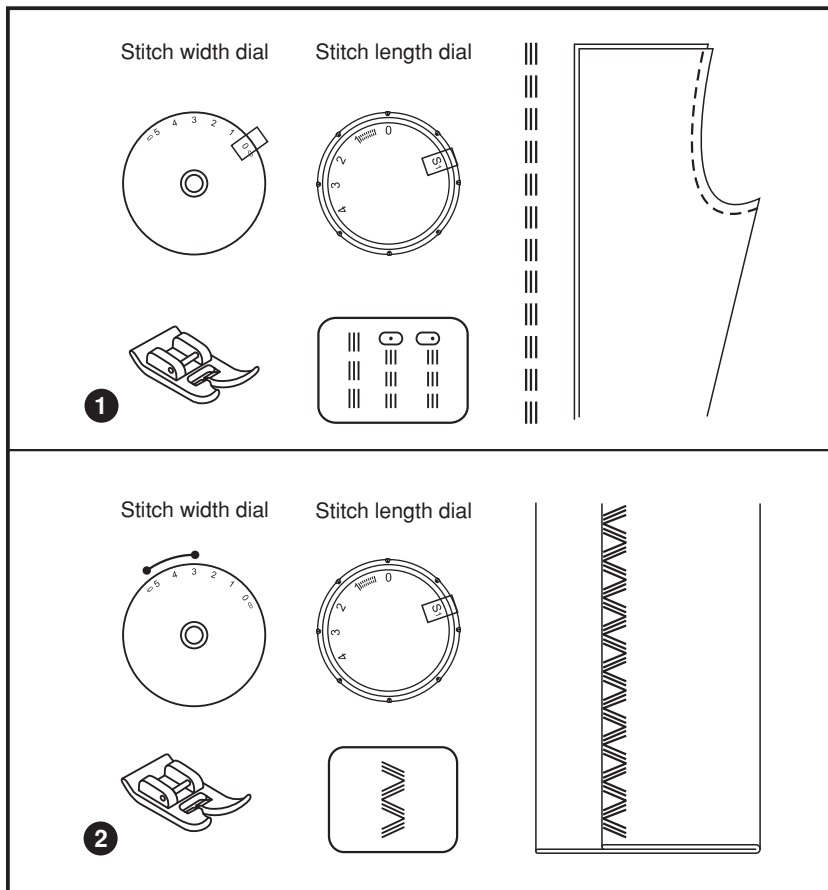

1. Triple straight stitch

For hardwearing seams.

Turn the stitch length dial to "S1".

The machine sews two stitches forwards and one stitch backwards. This gives triple reinforcement.

2. Triple zig-zag

For hardwearing seams, hems and decorative seams.

Turn the stitch length dial to "S1".

Adjust the stitch width dial to between "3" and "5". (model sew&go 5)

Triple zig-zag is suitable for firm fabrics like denim, corduroy, etc.

Seams, hems, T-shirts, underwear, etc.

Set the machine as illustrated.

This stitch can be used for all types of jersey as well as for woven fabrics. (1)

Sew at 1 cm (1/4") from the fabric edge and trim the surplus fabric. (2)

Stitch width dial

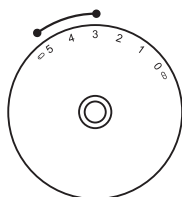

Stitch length dial

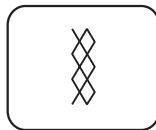
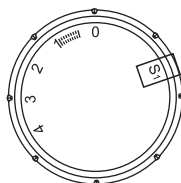

1



2

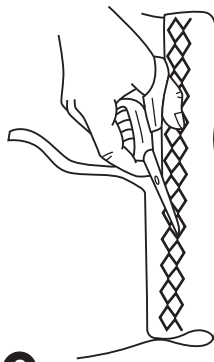

* The darning- / embroidery foot is an optional accessory and is not supplied with your machine.

Set the machine as illustrated.

1. Install the darning plate.

2. Remove the presser foot clamp.

3. Attach the darning foot to the presser foot holder. The lever (a) should be behind the needle clamp screw (b). Press the darning foot on firmly from behind with your index finger and tighten the screw (c).

4. First sew round the edge of the hole (to secure the threads). First row: Always work from left to right. Turn work by 1/4 and oversew.

A darning ring is recommended for easier sewing and better results.

Please Note:

No "S1" marking is shown on the stitch length dial by model sew&go 1.

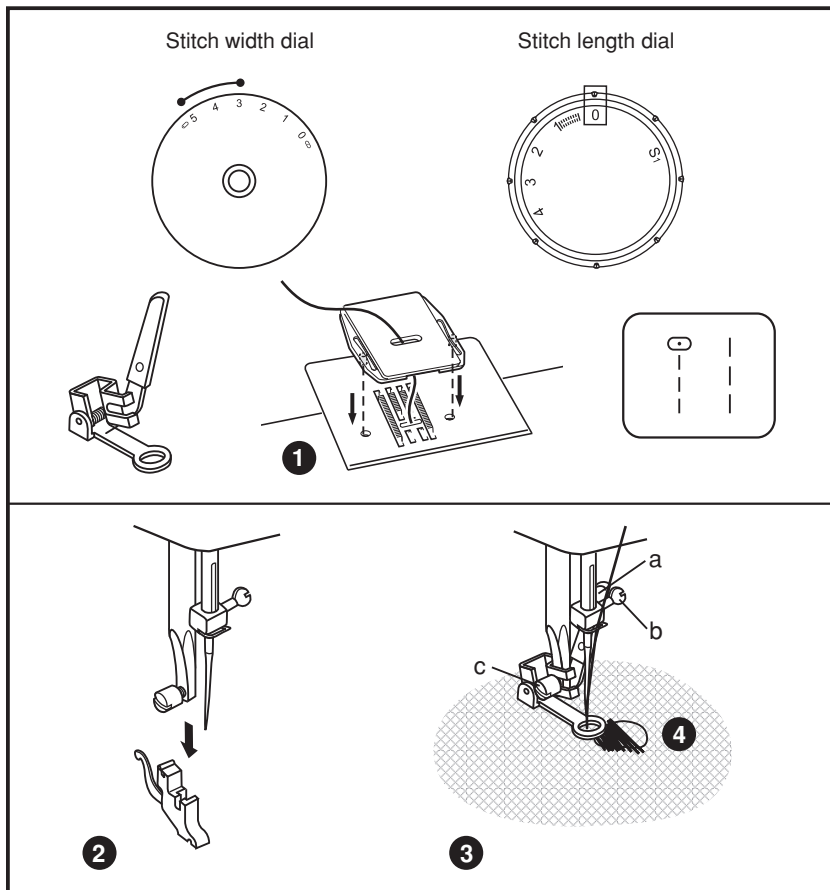

Set the machine as illustrated.

1. Shell hem

For decorative edges.

Suitable for edges on sheer, fine and stretch fabrics. The larger stitch should go just over the edge of the fabric to create the shell effect.

- This stitch requires a tighter thread tension than normal.
- Place the fabric under the presser foot so that it will be sewn along the bias with the straight stitches sewn on the seamline and the zigzag stitches sewn slightly over the folded edge.
- Sew at a slow speed.

2. Rampart

For flat joining seams, sewing on elastic, visible hems.

This stitch can be used for firm, thicker fabrics.

3. Bridging

For seams, place mats, tablecloths.

Decorative joining seam for a fagoted effect. Gathering with cord or shirring elastic.

Please Note:

No "S1" marking is shown on the stitch length dial by model sew&go 1.

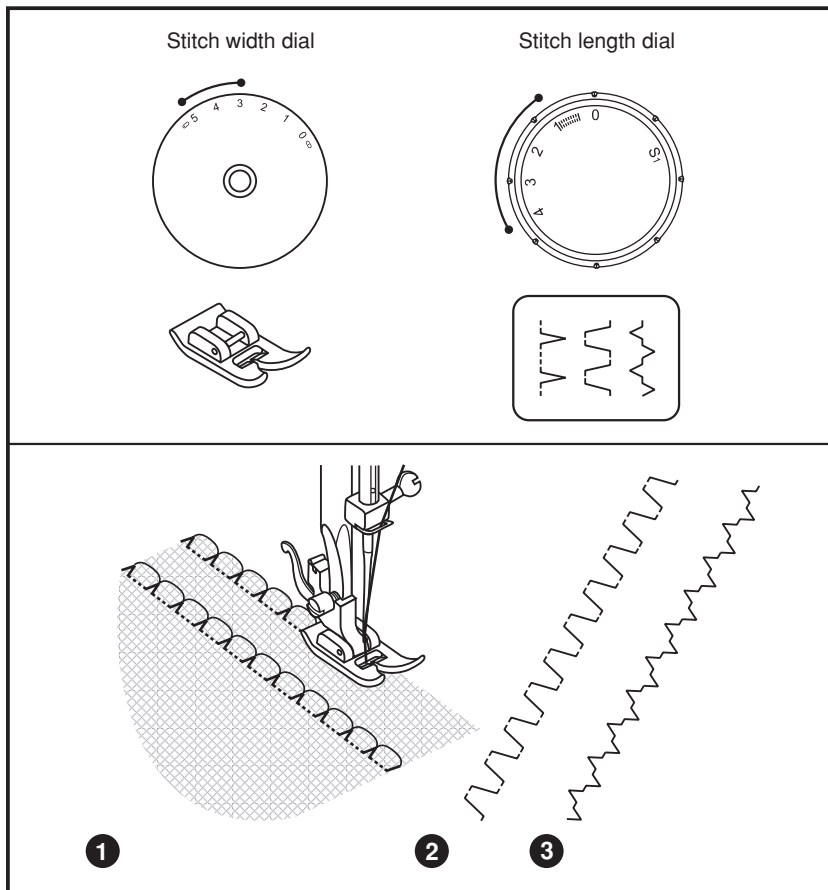

* The quilting foot is an optional accessory and is not supplied with your machine.

Set the machine as illustrated.

Insert the seam guide right in presser foot holder and set the space as you desired.

Move the fabric over and sew successive rows with the guide riding along on the previous row of stitching.

Please Note:

No "S1" marking is shown on the stitch length dial by model sew&go 1.

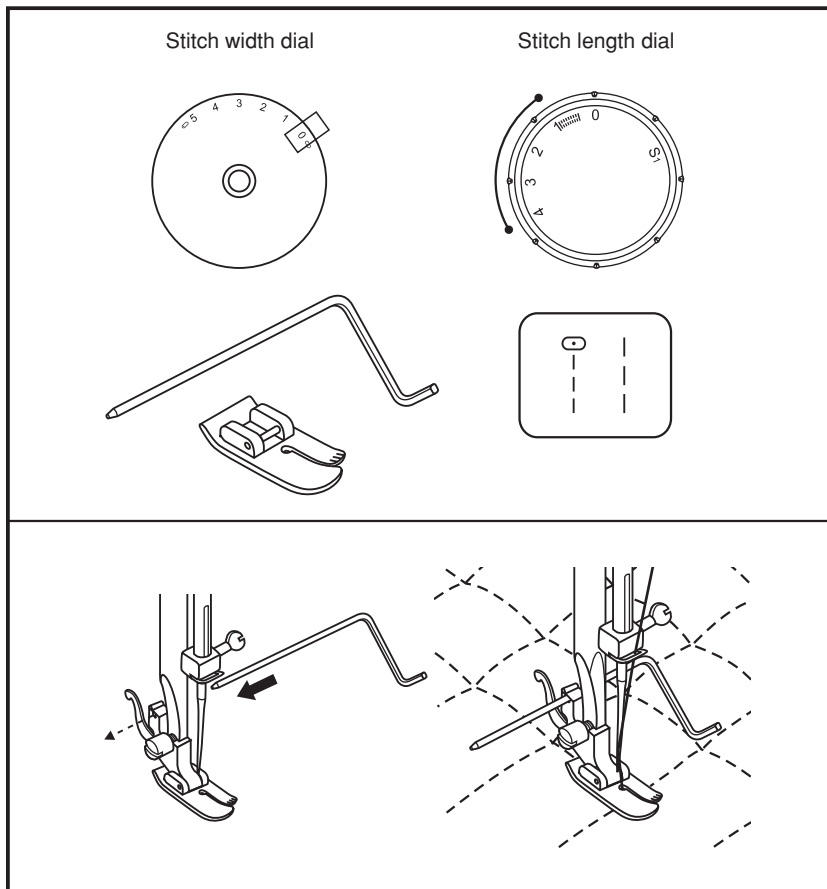

Stitch width dial

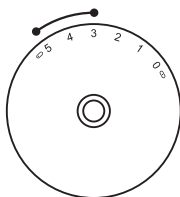

Stitch length dial

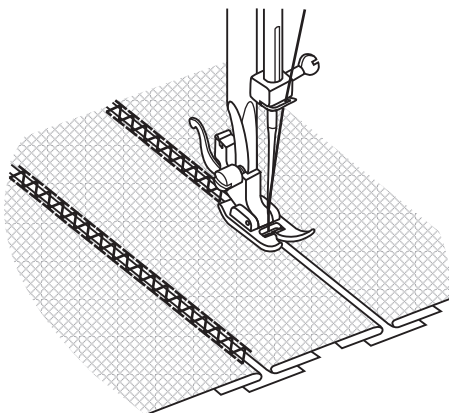
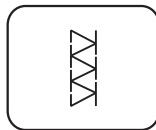
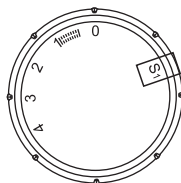

These stitches are used to join two pieces of fabric while leaving a space between their edges.

- Fold over the edges of the two pieces of fabric for the hem and baste the edges to a thin piece of paper leaving a small space between them.
- Set the Pattern selector as illustrated. Turn the stitch length dial to "S1".
- Stitch along the edge, pulling both threads slightly when beginning to sew.
 - * Use thicker than normal threads for sewing.
- After sewing, remove the basting and the paper. Finish by tying knots on the reverse side at the beginning and the end of the seams.

Stitch width dial

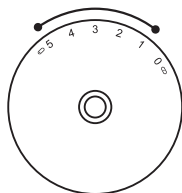

Stitch length dial

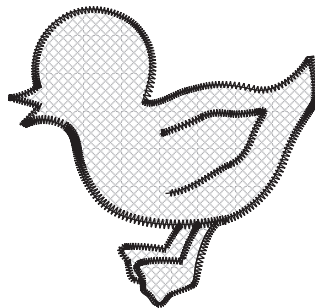
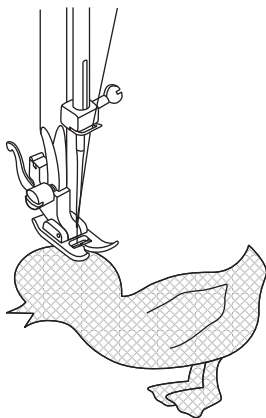
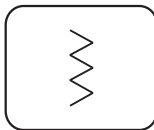
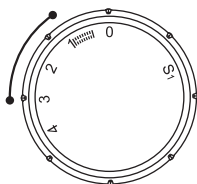

- Turn stitch length dial to the desired length.
- Turn stitch selector dial to small zig zag width.
- Cut out the applique design and baste it to the fabric.
- Sew slowly around the edge of the design.
- Trim excess material outside the stitching. Make sure not to cut any stitches.
- Remove the basting thread.
- Tie top and bottom thread under the applique to avoid unraveling.

Please Note:

No "S1" marking is shown on the stitch length dial by model sew&go 1.

Stitch width dial

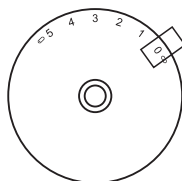

Stitch length dial

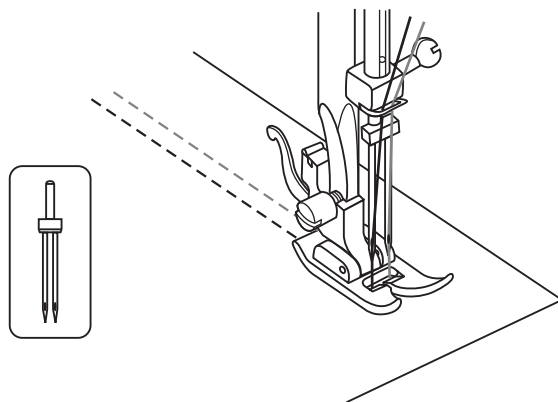
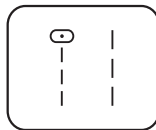
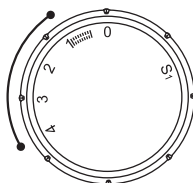

* The twin needle is an optional accessory and is not supplied with your machine.

- Turn stitch length dial to the desired stitch length.
- Pattern selector on " | " or " | | ". Center needle position.
- Make sure that the two threads used to thread the twin needle are of the same weight. You can use one or two colors.
- Insert the twin needle in the same way as single needle. Flat side of needle should face away from you.
- Insert the second spool pin on top of the machine for the second thread. Follow instructions for single needle threading. Thread each needle separately.

Please note:

When sewing with twin needle, always proceed slowly, and make sure to maintain low speed to insure quality stitching. When using twin needle on zigzag make sure the stitch width dial is set between "0" and "3.0". Do not use twin needle at setting above "3.0". (model sew&go 5)

Use only twin needle assemblies with max. 2 mm needle distance. (i.e. bernette part number 502020.62.91)

Please Note:

No "S1" marking is shown on the stitch length dial by model sew&go 1.

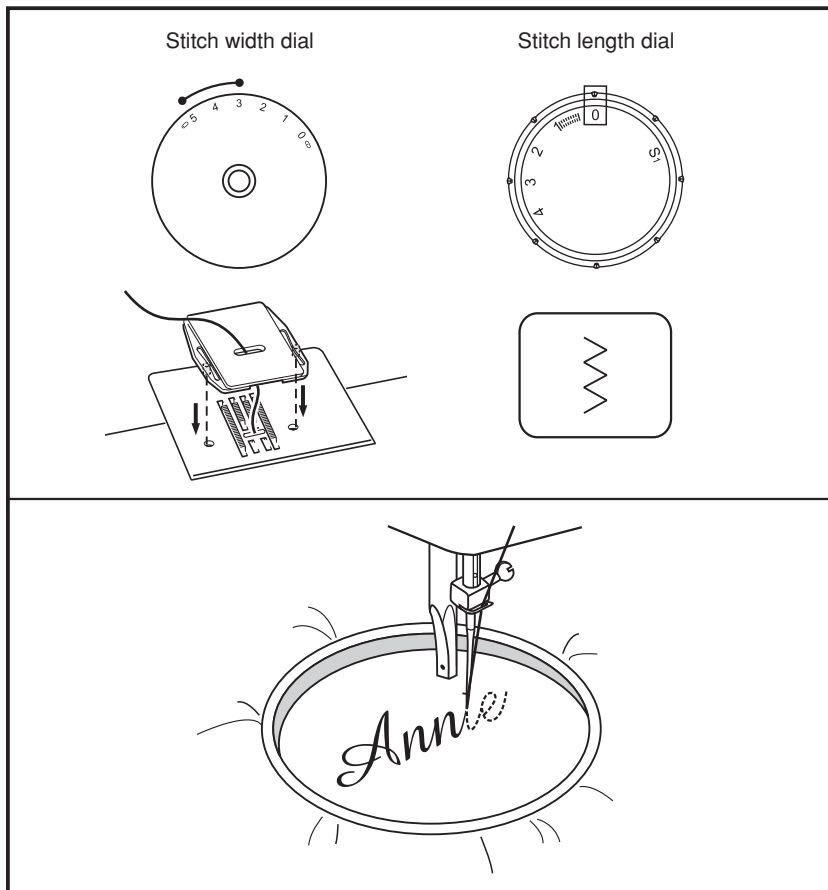

- Set the machine as illustrated.
- Remove the presser foot and the presser foot holder.
- Attach the darning plate.
- Lower presser foot lever before starting to sew.
- Adjust the stitch width according to the size of lettering or design (only possible for model sew&go 5).

Preparation for Monogramming and Embroidering*

- Draw the desired lettering or design on the right side of the fabric.
- Stretch the fabric between embroidery hoop as firmly as possible.
- Place the fabric under the needle. Make sure the presser foot bar is down in its lowest position.
- Turn the handwheel towards you to bring up the lower thread through the fabric. Sew a few securing stitches at the starting point.
- Hold the hoop with thumb and forefingers of both hands and guide the embroidery hoop.

* Embroidery hoop not included with machine.

Please Note:

No "S1" marking is shown on the stitch length dial by model sew&go 1.

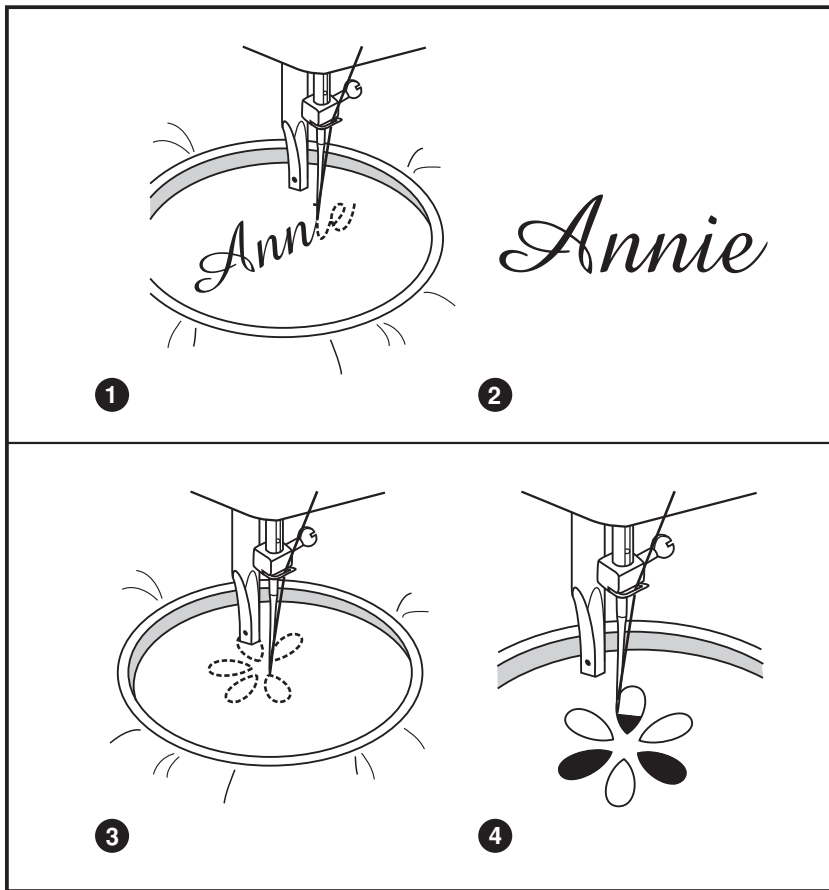

Monogramming

1. Sew, moving the hoop slowly along the lettering at a constant speed.
2. Secure with a few straight stitches at the end of the last letter.

Embroidering

3. Stitch the outline of the design by moving the embroidery hoop.
4. Fill in the design working from the outline of the design to the inside and from the inside to the edge of the outline until the design is completely filled in. Keep the stitching close together.

* A long stitch is made by moving the hoop rapidly and a short stitch is made by moving it slowly.

Secure with a few straight stitches at the end of the design.

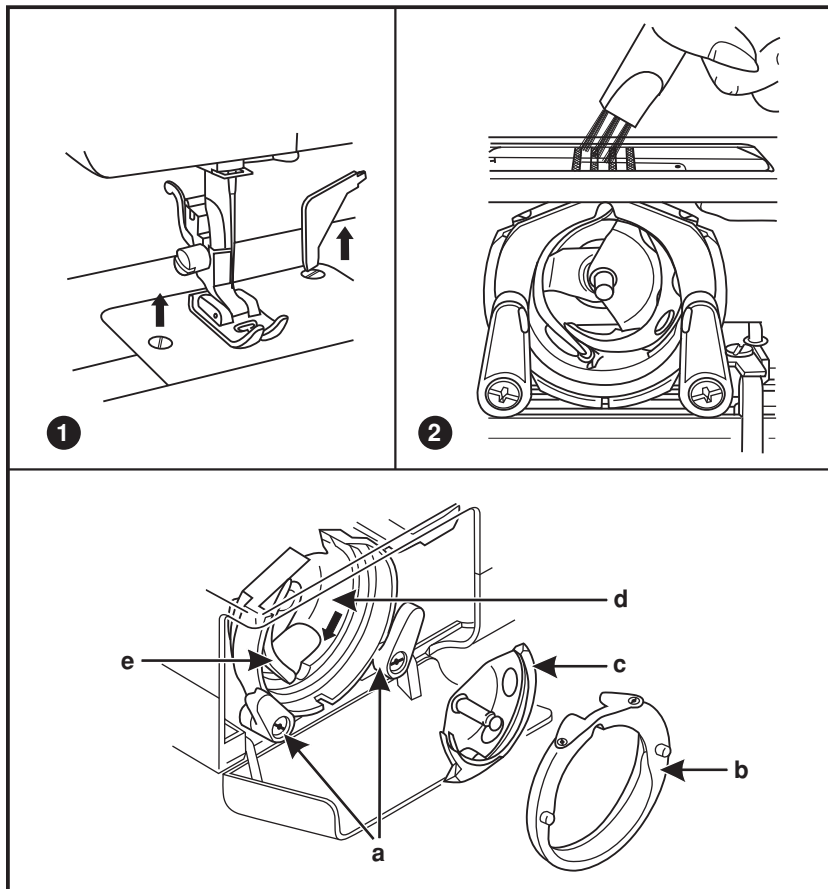

Attention:

Disconnect the machine from the electricity supply by removing the plug from the mains socket. When cleaning the machine, it must always be disconnected from the electricity supply.

Remove the needle plate:

Turn the handwheel until the needle is fully raised. Open the hinged front cover and unscrew the stitch plate screws with the screw driver. (1)

Cleaning the feed dog:

Remove the bobbin case and use the brush supplied to clean the whole area. (2)

Cleaning and lubricating the hook:

Remove the bobbin case. Snap the two hook retaining arms (a) outwards. Remove the hook race cover (b) and the hook (c) and clean with a soft cloth. Lubricate at the points (d) (1-2 drops) with sewing machine oil. Turn the handwheel until the hook race (e) is in the left position. Replace the hook (c). Replace the hook race cover and snap back the two hook retaining arms. Insert the bobbin case and bobbin and replace the stitch plate.

Important:

Fabric fluff and threads must be removed regularly. Your machine should be serviced at regular intervals at one of our service agencies.

Problem	Cause	Correction
Upper thread breaks	<ol style="list-style-type: none"> 1. The machine is not threaded correctly. 2. The thread tension is too tight. 3. The thread is too thick for the needle. 4. The needle is not inserted correctly. 5. The thread is round wound the spool holder pin. 6. The needle is damaged. 	<ol style="list-style-type: none"> 1. Rethread the machine. 2. Reduce the thread tension (lower number). 3. Select a larger needle. 4. Remove and reinsert the needle (flat side towards the back). 5. Remove the reel and wind thread onto reel. 6. Replace the needle.
Lower thread breaks	<ol style="list-style-type: none"> 1. The bobbin case is not inserted correctly. 2. The bobbin case is threaded wrongly. 	<ol style="list-style-type: none"> 1. Remove and reinsert the bobbin case and pull on the thread. The thread should pull easily. 2. Check both bobbin and bobbin case.
Skipped stitches	<ol style="list-style-type: none"> 1. The needle is not inserted correctly. 2. The needle is damaged. 3. The wrong size needle has been used. 4. The foot is not attached correctly. 	<ol style="list-style-type: none"> 1. Remove and reinsert needle (flat side towards the back). 2. Insert a new needle. 3. Choose a needle to suit the thread and fabric. 4. Check and attach correctly.
Needle breaks	<ol style="list-style-type: none"> 1. The needle is damaged. 2. The needle is not correctly inserted. 3. Wrong needle size for the fabric. 4. The wrong foot is attached. 	<ol style="list-style-type: none"> 1. Insert a new needle. 2. Insert the needle correctly (flat side towards the back). 3. Choose a needle to suit the thread and fabric. 4. Select the correct foot.
Loose stitches	<ol style="list-style-type: none"> 1. The machine is not correctly threaded. 2. The bobbin case is not correctly threaded. 3. Needle/ fabric/ thread combination is wrong. 4. Thread tension wrong. 	<ol style="list-style-type: none"> 1. Check the threading. 2. Thread the bobbin case as illustrated. 3. The needle size must suit the fabric and thread. 4. Correct the thread tension.
Seams gather or pucker	<ol style="list-style-type: none"> 1. The needle is too thick for the fabric. 2. The stitch length is wrongly adjusted. 3. The thread tension is too tight. 4. Fabric puckers. 	<ol style="list-style-type: none"> 1. Select a finer needle. 2. Readjust the stitch length. 3. Loosen the thread tension. 4. Use a stabilizer for fine or stretchy fabrics.
Uneven stitches, uneven feed	<ol style="list-style-type: none"> 1. Poor quality thread. 2. The bobbin case is wrongly threaded. 3. Fabric has been pulled. 	<ol style="list-style-type: none"> 1. Select a better quality thread. 2. Remove bobbin case, retreat and insert correctly. 3. Do not pull on the fabric while sewing, let it be taken up by the machine.
The machine is noisy	<ol style="list-style-type: none"> 1. The machine must be lubricated. 2. Fluff or oil have collected on the hook or needle bar. 3. Poor quality oil has been used. 4. The needle is damaged. 	<ol style="list-style-type: none"> 1. Lubricate as described. 2. Clean the hook and feed dog as described. 3. Only use good quality sewing machine oil. 4. Replace the needle.
The machine jams	Thread is caught in the hook.	Remove the upper thread and bobbin case, turn the handwheel backwards and forwards by hand and remove the thread remains. Lubricate as described.

EN 08/2015 - 2. Edition
5029135.0.04 / 021K5L0101(A)
©BERNINA International AG
Steckborn CH, www.bernina.com



www.mybernette.com