

Clipping & Corners

Clipping seams allows a curve to lie flat and a corner to turn, giving a nice flat curve or a sharp turned point. Clipping a seam is to cut or snip within the seam allowance. The 'cut' extends from the outer edge of the seam allowance to the line of stitching.

Use just the points of a sharp pair of scissors to clip into the seam allowance, cutting close to, but not into, your line of the stitching.

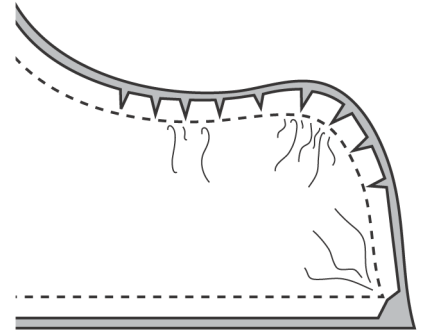

Outside Corners - Method 1

Approximately 1/2" (1- 1.5cm) before each corner, reduce the stitch length to 1.5mm; this will help prevent the fabric in the corners from unraveling.

One stitch before the corner, stop with needle down in fabric. Raise presser foot and pivot fabric halfway. Lower presser foot and take 1-2 stitches across the point, ending with needle down. Raise presser foot and complete pivot. Continue sewing small stitches for 1/2", then return to normal stitch length. Grade seam allowances.

Clip curve and trim corners.

Press seams, then press seam allowances open as much as possible.

Tip A point presser is useful for pressing into corners of collars, cuffs, and vents.

Reduce your stitch length going into and out of the corner.

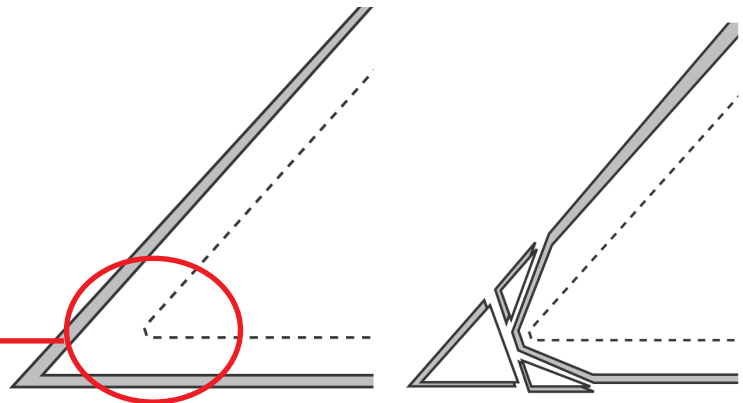

Outside Corners - Method 2

Stitch one side, sewing all the way to the raw edge; stitch second side, sewing all the way to the raw edge, overlapping stitching at corner. **Do not trim corner.**

Fold seam allowances to underside of collar (fold point under, then sides) and turn collar right side out; seam allowances will fill the corner and provide a firm edge.

Tip Use a point presser to help form the corner.

