

10 x 10 cm

4 x 4 Inch

1

2A

1A

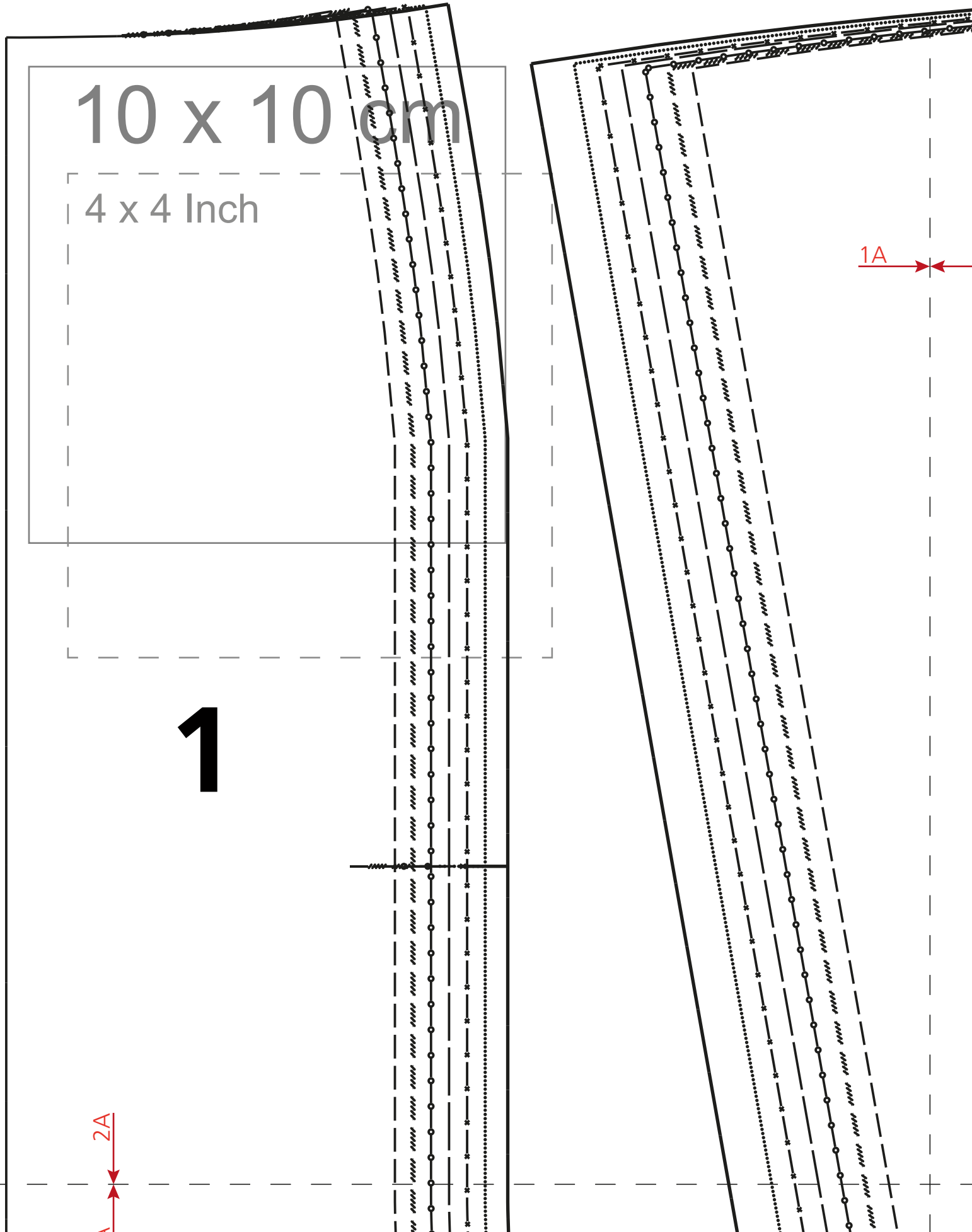

1A

1B

Skirt „Diamond“ 323-13

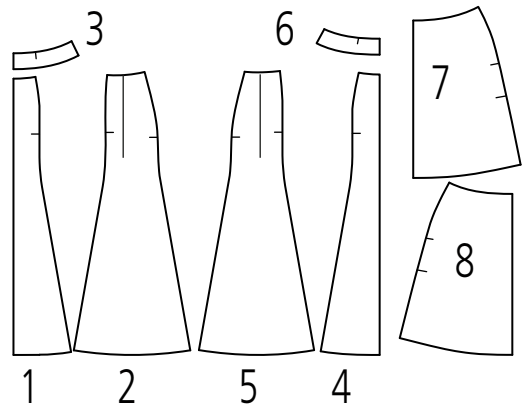
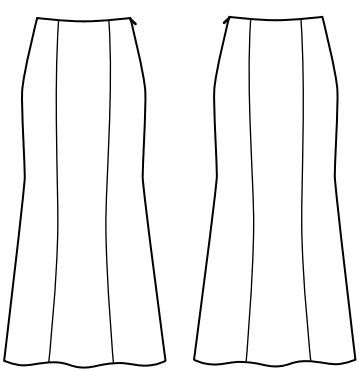

2B

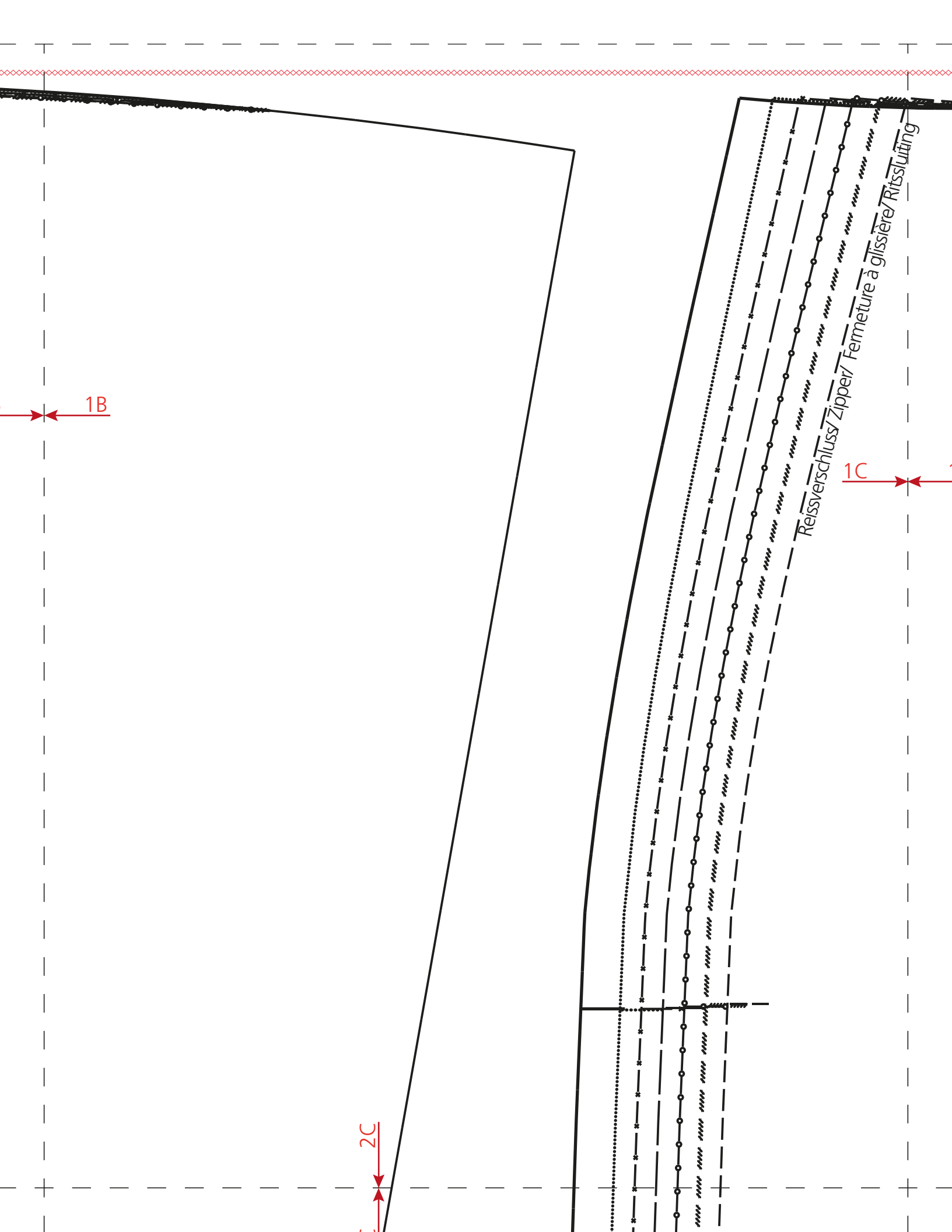

Structure à glissière/Ritschlüftung

1C

Fadenlauf/ Straight grain/ Droit fil/ Draadrichting

2D

1D

Vord. M. Stoffbr. Faden!./

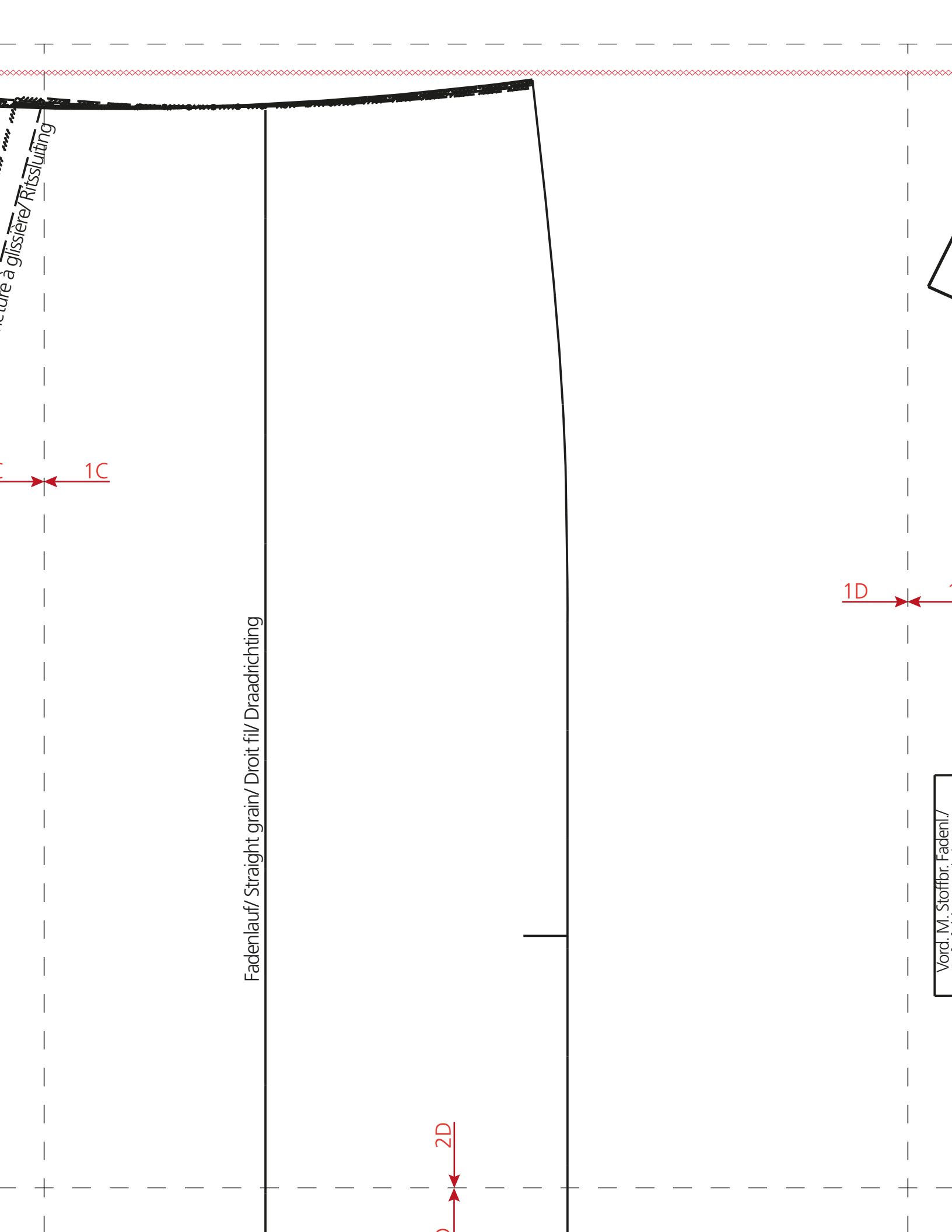

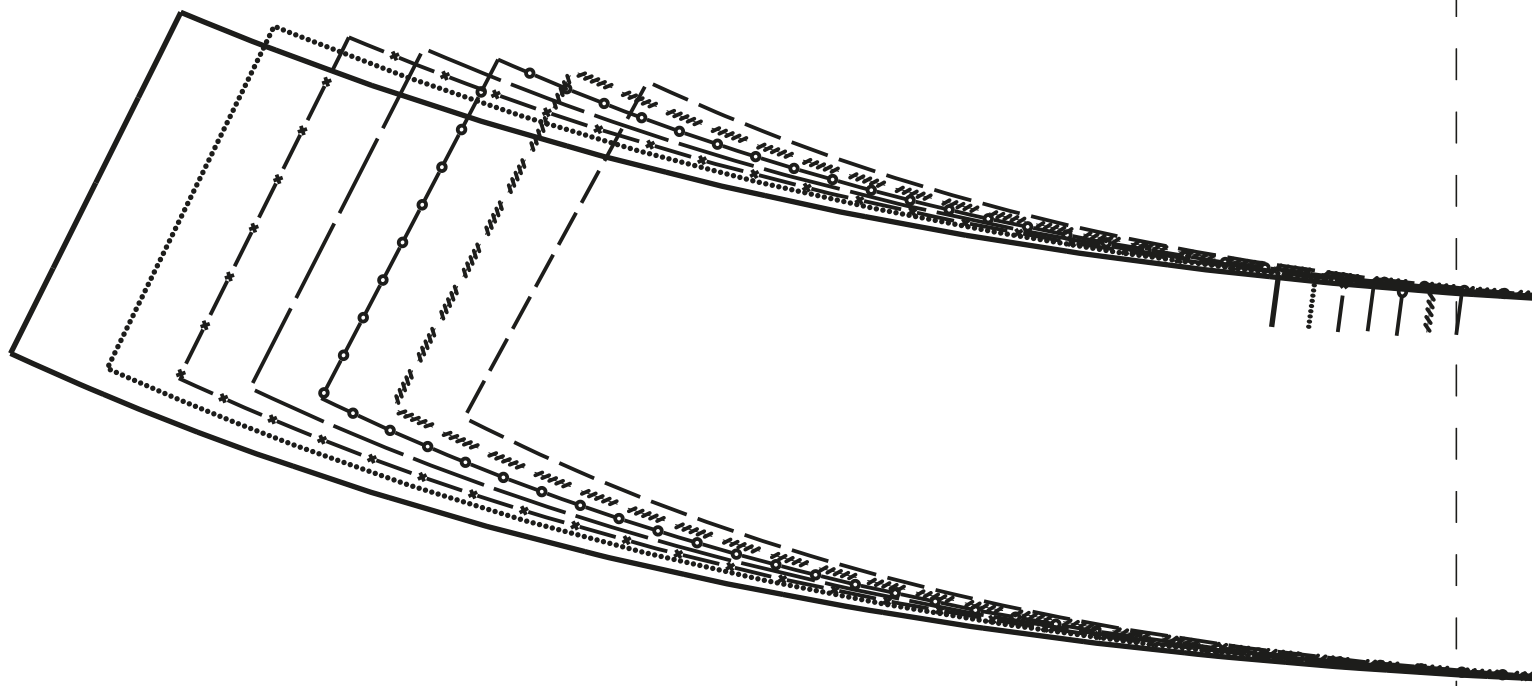

1D

Vord. M. Stoffbr. Faden./
 C. fr. fold str. grain/
 Mil. endr. pli droit fil/
 Middenv. stofv. draadr.

3

1E

2E

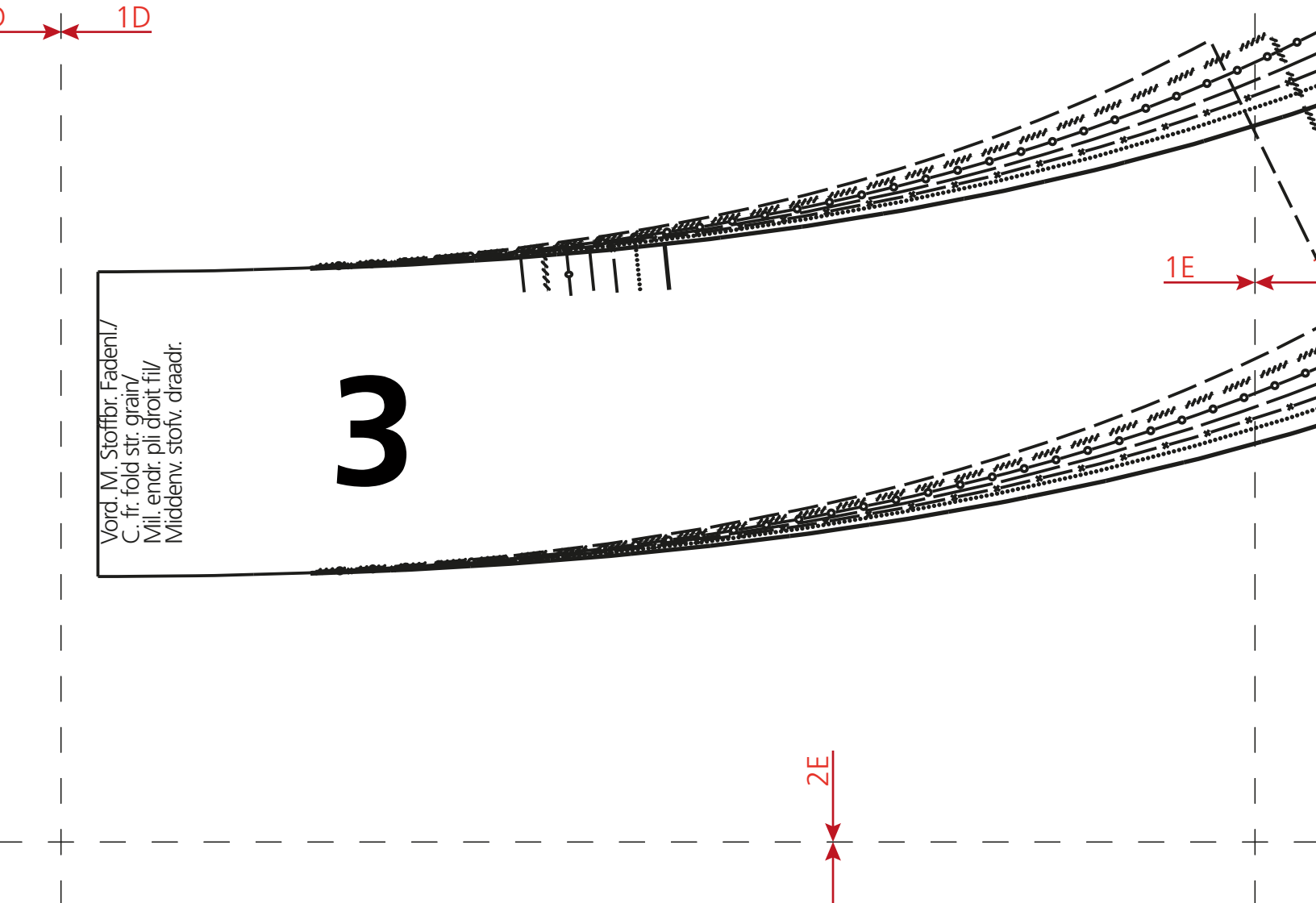

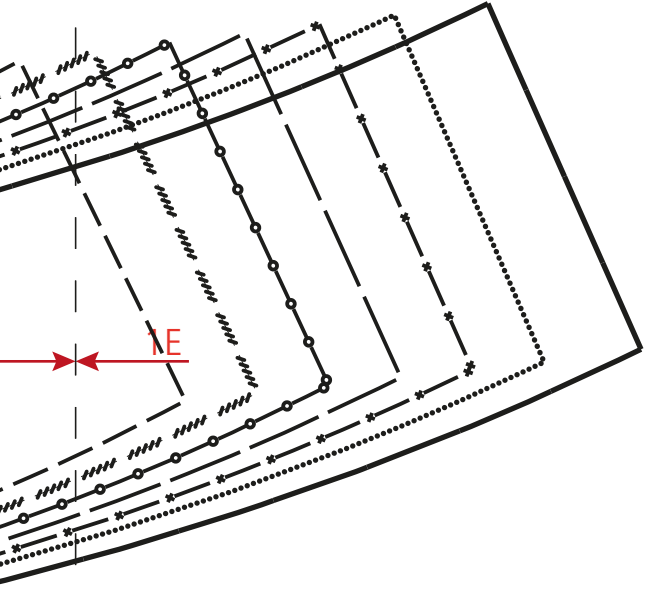

6

Rückw. M. Stoffbr. Fadenl. /
 Centre back fold str. grain /
 Milieu envers pli droit fil /
 Middena. stofv. draadrichting

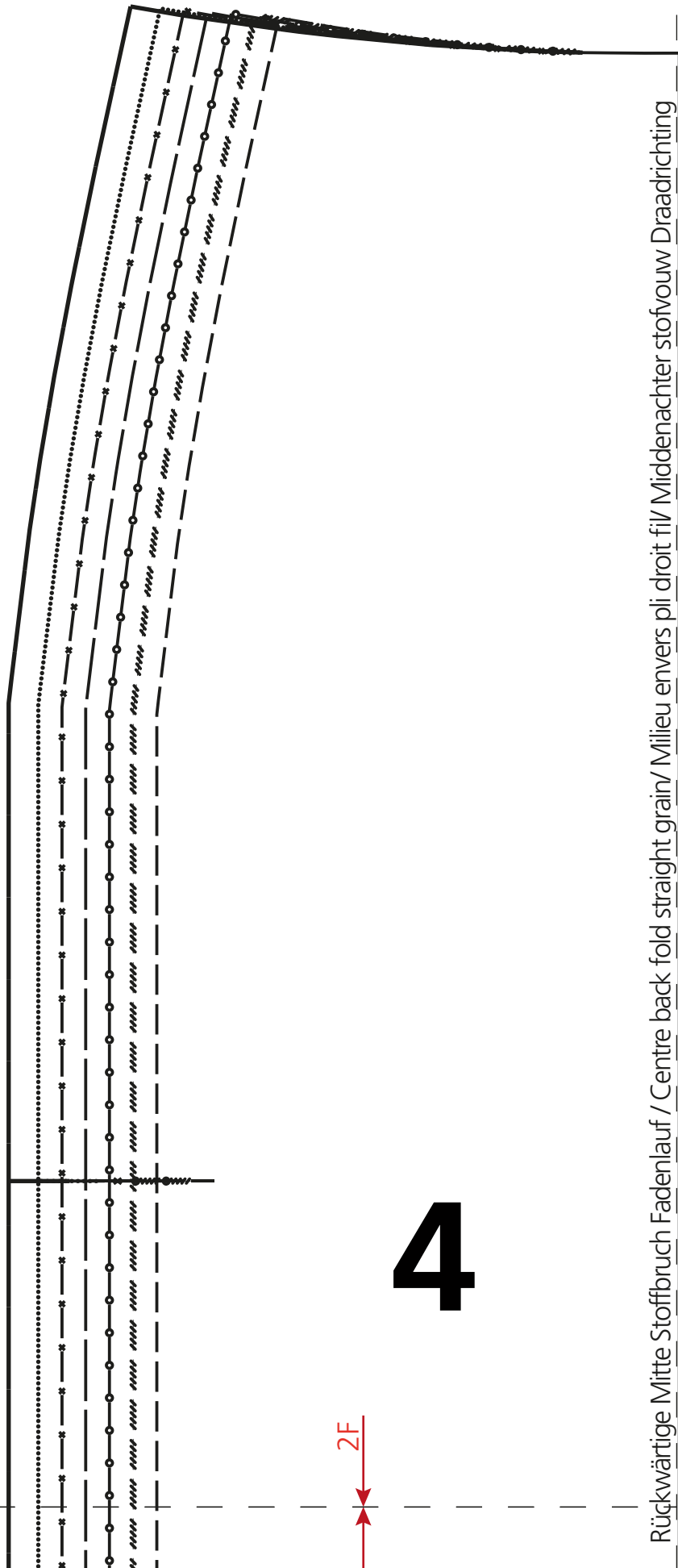

4

2F

Rückwärtige Mitte Stoffbruch Fadenlauf / Centre back fold straight grain / Milieu envers pli droit fil / Middenachter stofvouw Draadrichting

Vordere Mitte Stoffbruch Fadenlauf/ Centre front fold straight grain/ Milieu endroit pli droit fil/ Middenvoor stofvouw draadrichting

$2A$

$3A$

$2A$

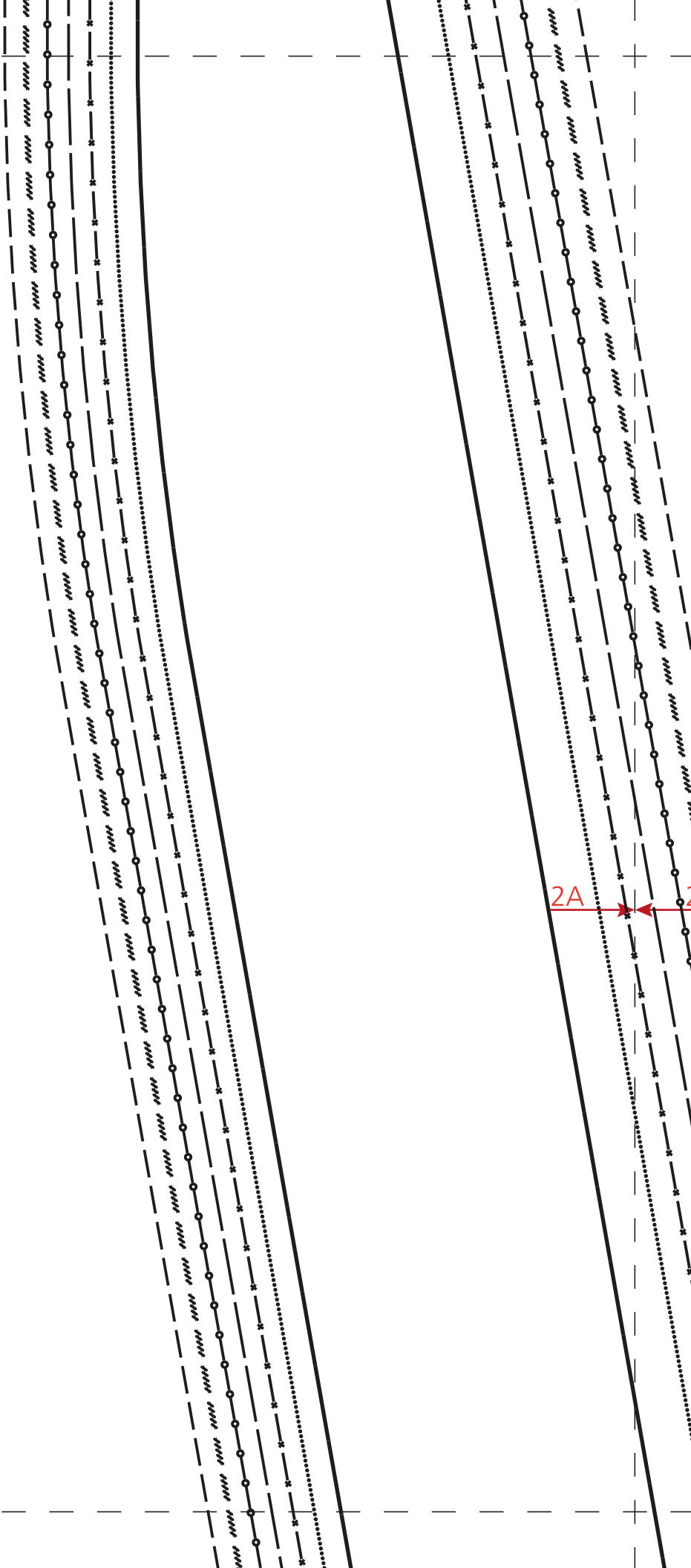

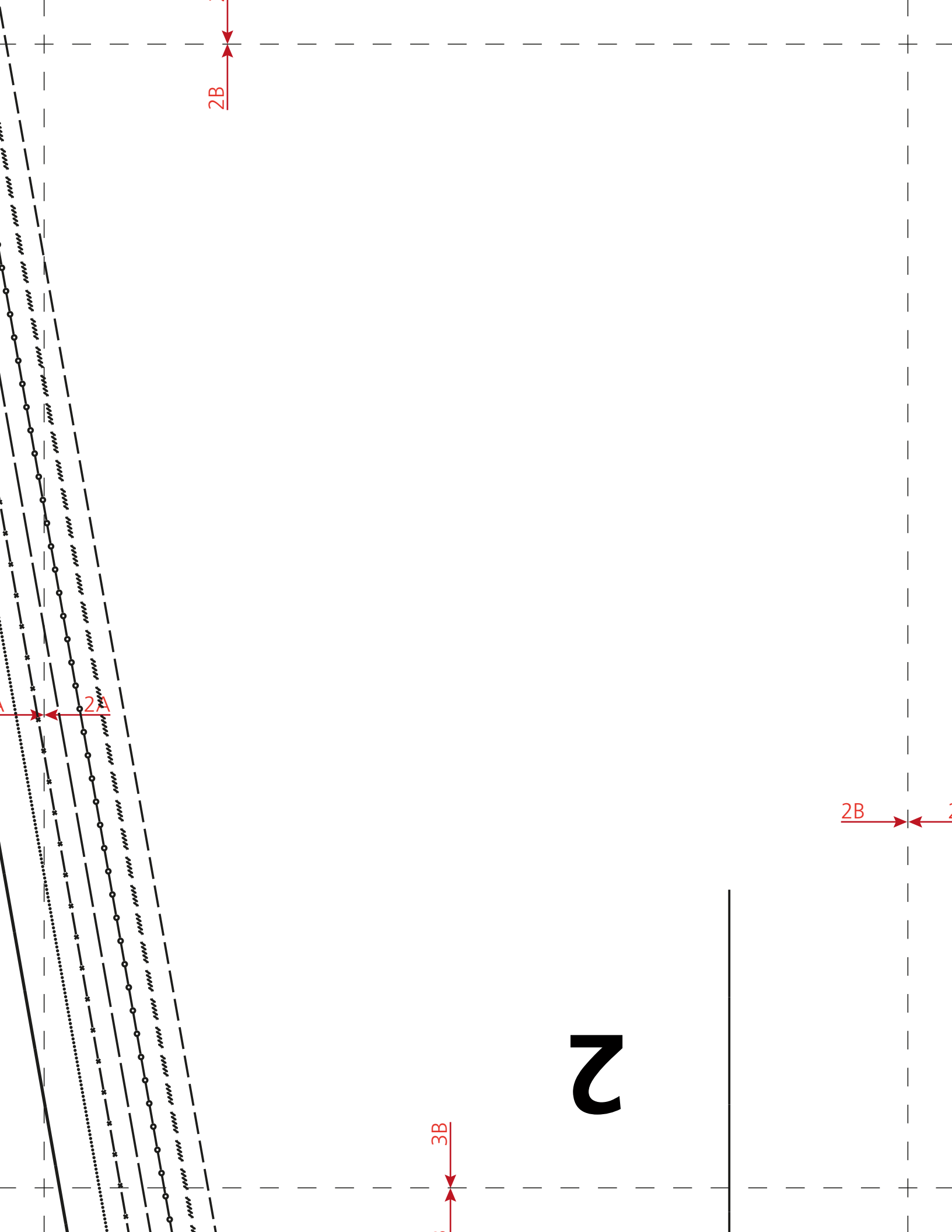

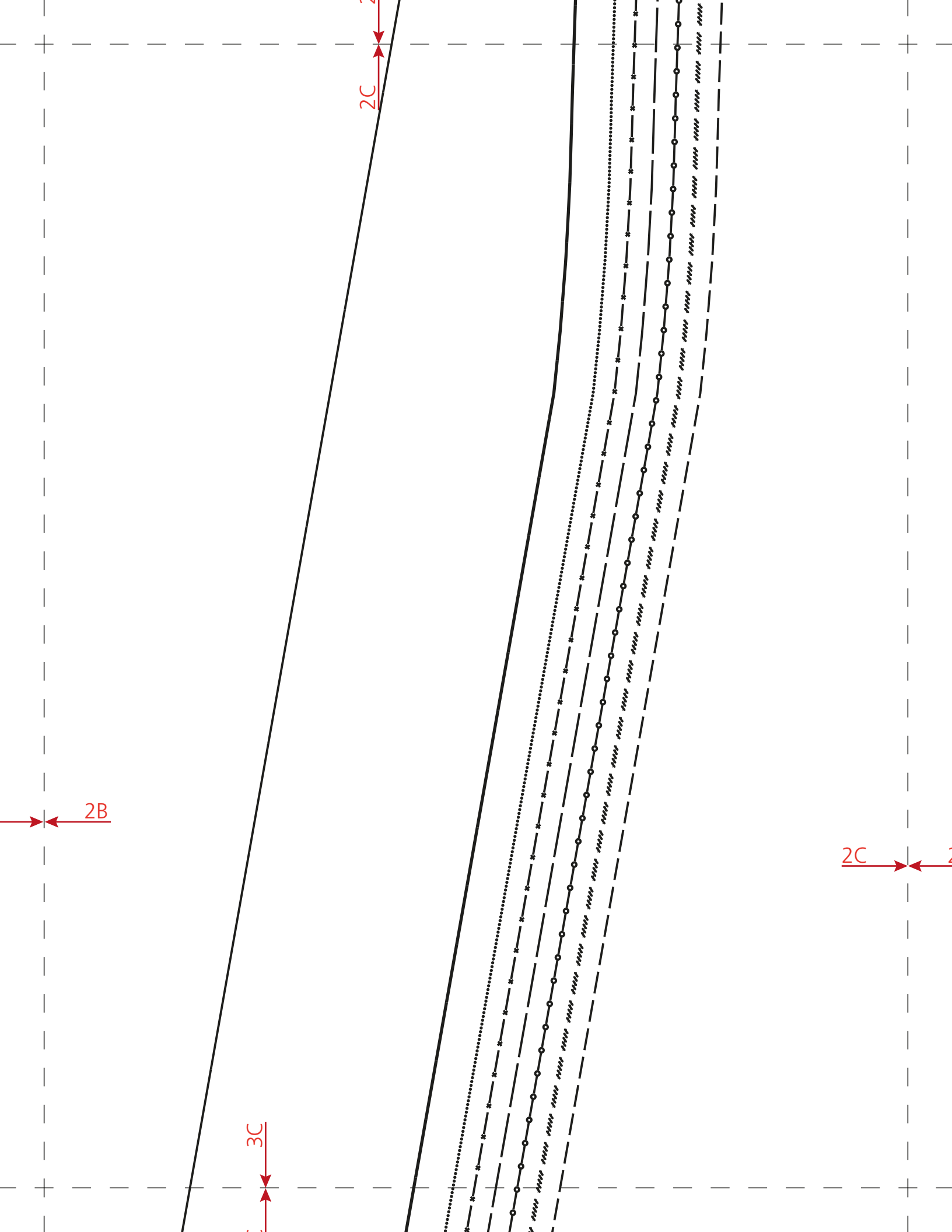

5

$2C$

$2D$

$3D$

$2D$

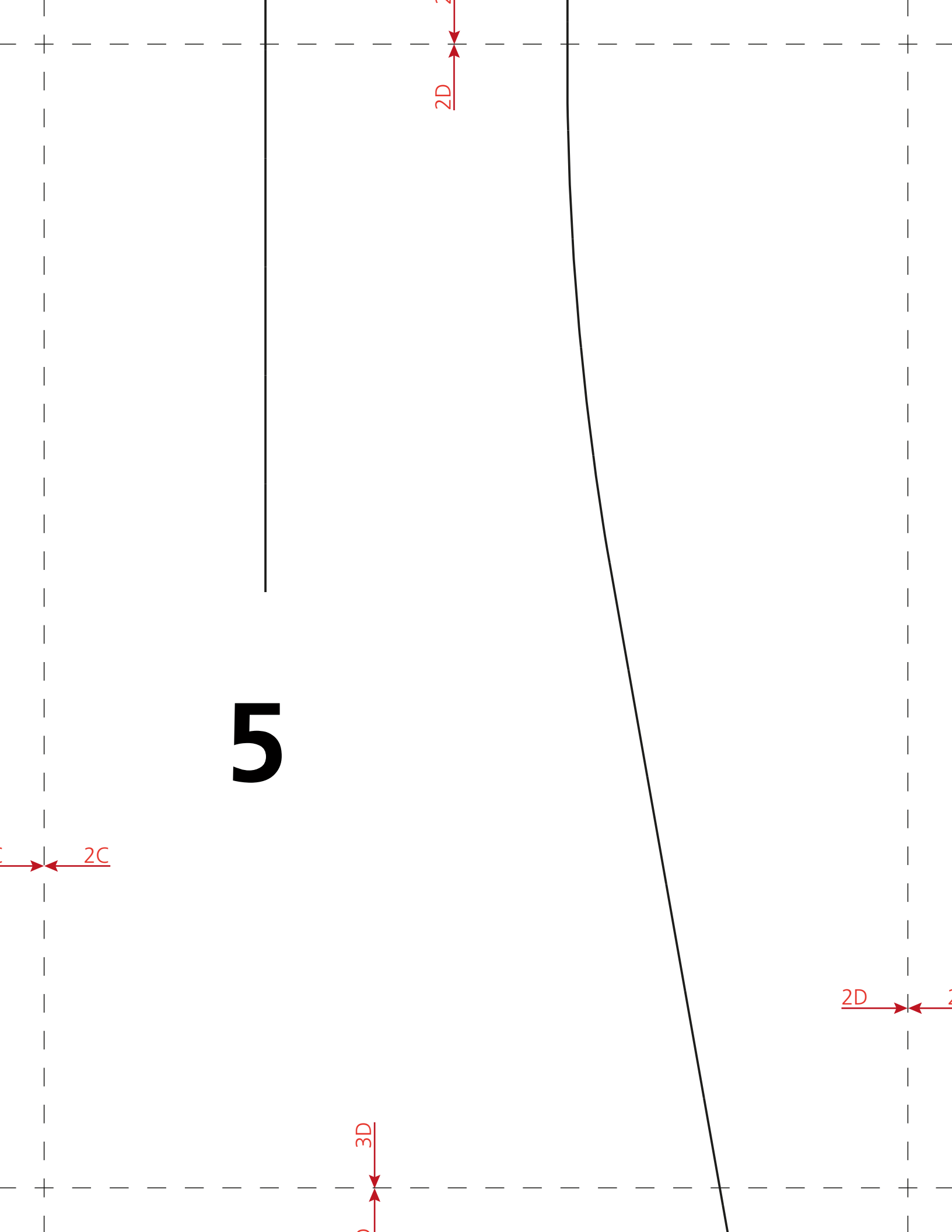

2E

| Für Körpergröße/ for height/ pour la taille/ Maten voor lichaamsgrootte 168 cm | | | | | | | | |
|--|----|----|----|----|-----|-----|-----|-----|
| Größe/ Size/ Taille/ Maat | 34 | 36 | 38 | 40 | 42 | 44 | 46 | 48 |
| Oberweite/Bust/ Poitrine/ Bovenwijdte | 80 | 84 | 88 | 92 | 96 | 100 | 104 | 110 |
| Tailenweite/ Waist/ Taille/ Tailenwijdte | 64 | 67 | 71 | 75 | 79 | 83 | 87 | 93 |
| Hüftweite/ Hip/ Hanche/ Heupwijdte | 90 | 93 | 96 | 99 | 102 | 105 | 108 | 114 |
| Vord. Tailleng./ Front waist length/ Longueur taille devant/ Taillelengte voor | 42 | 43 | 44 | 45 | 46 | 47 | 48 | 49 |
| Rückw. Tailleng./ Back waist length/ Longueur taille dos/ Ruglengte tot taille | 41 | 41 | 41 | 42 | 42 | 42 | 42 | 43 |

| Legende/ Legend/ Légend | |
|-------------------------|------------|
| Größe/ | ----- 34 |
| Size/ | ----- 36 |
| Taille/ | ----- 38 |
| Maat | //// // 38 |
| | —○—○—○ 40 |
| | ----- 42 |
| | —*—*—* 44 |
| | 46 |
| | ----- 48 |

| for height 66 Inchi: | Taille | 34 | 36 | 38 | 40 | 42 | 44 | 46 | 48 |
|----------------------|--------|------|------|------|------|------|------|------|------|
| Bust | | 31,5 | 33,0 | 34,6 | 36,2 | 37,8 | 39,4 | 40,9 | 43,3 |
| Waist | | 25,2 | 26,4 | 28,0 | 29,5 | 31,1 | 32,7 | 34,3 | 37,0 |
| Hip | | 35,4 | 36,6 | 37,8 | 39,0 | 40,2 | 41,3 | 42,5 | 44,9 |
| Front waist length | | 16,5 | 17,0 | 17,3 | 17,7 | 18,0 | 18,5 | 18,9 | 19,2 |
| Back waist length/ | | 16,0 | 16,0 | 16,0 | 16,5 | 16,5 | 16,5 | 16,5 | 16,9 |

Wichtig: Alle Schnittteile sind ohne Nahtzugabe, falls nichts anderes vermerkt ist!

Important: All patterns are without seam allowances, unless otherwise indicated!

Important: Toutes découpes sont sans surplus de couture (sauf mention contraire)!

Attentie: Alle patroondeelen zijn zonder naadtoeslag, tenzij anders vermeld!

2D

3E

2E

Vorder

3A

A 4A

3A

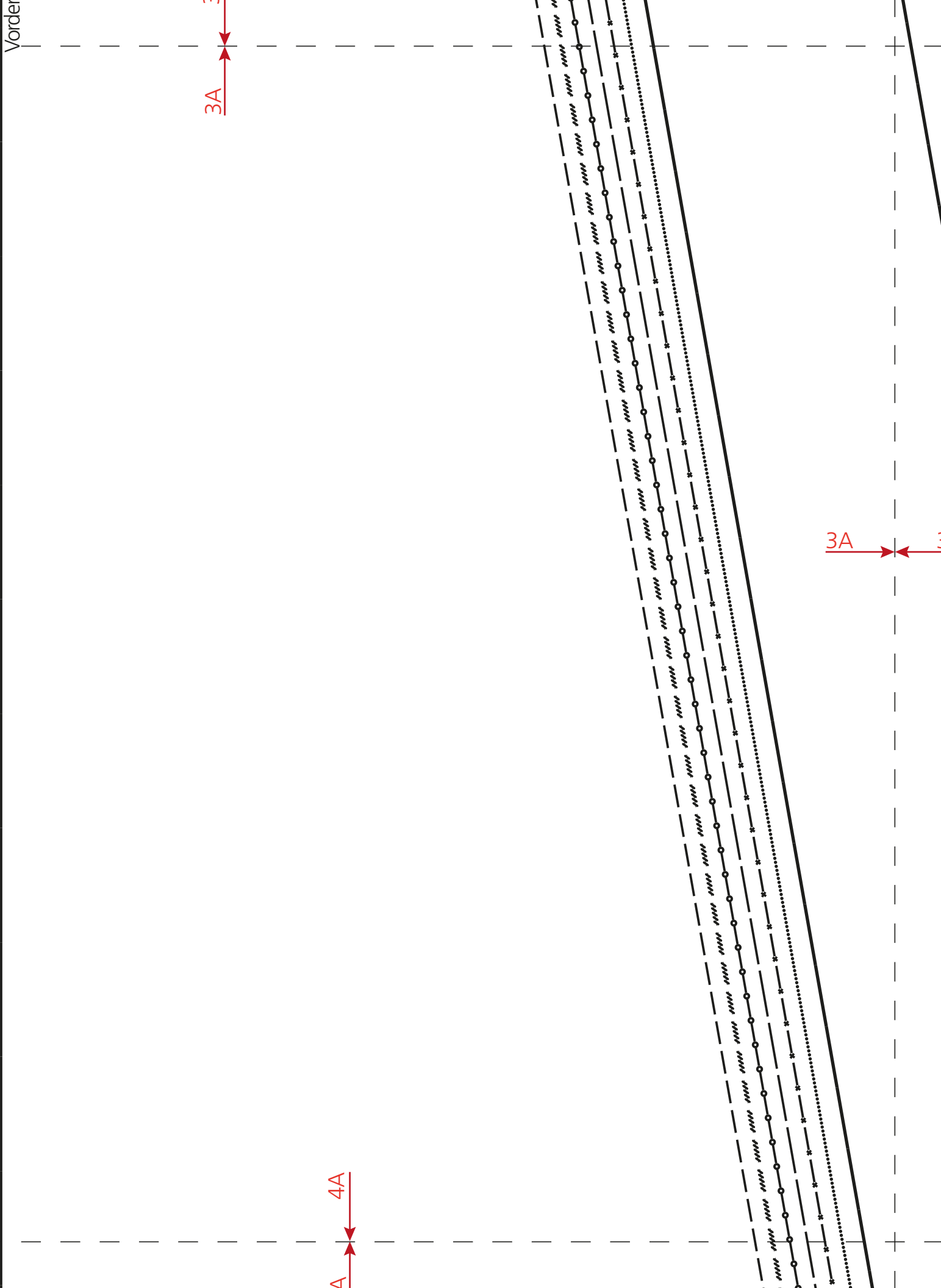

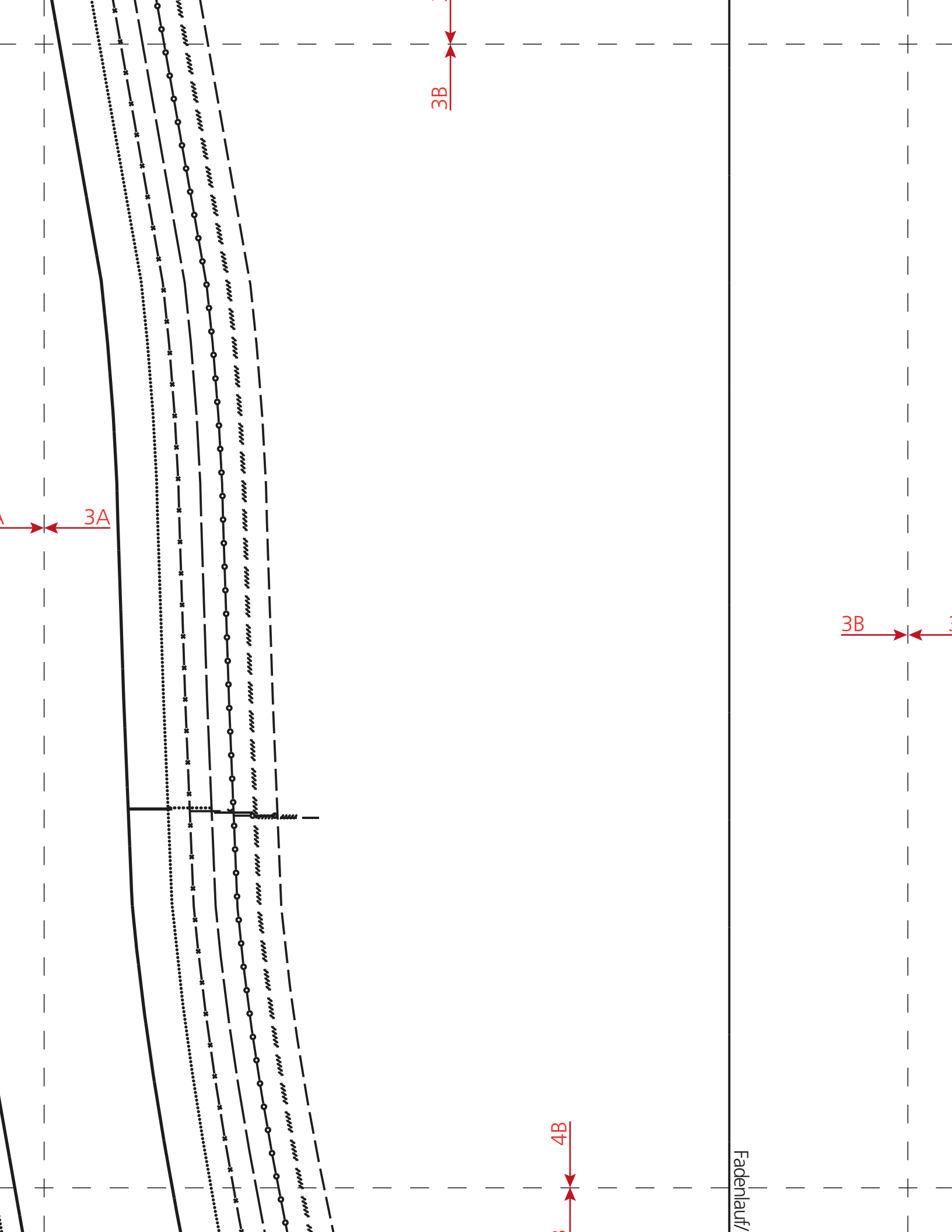

$3A$

$3B$

$3B$

$4B$

Fadenlauf/

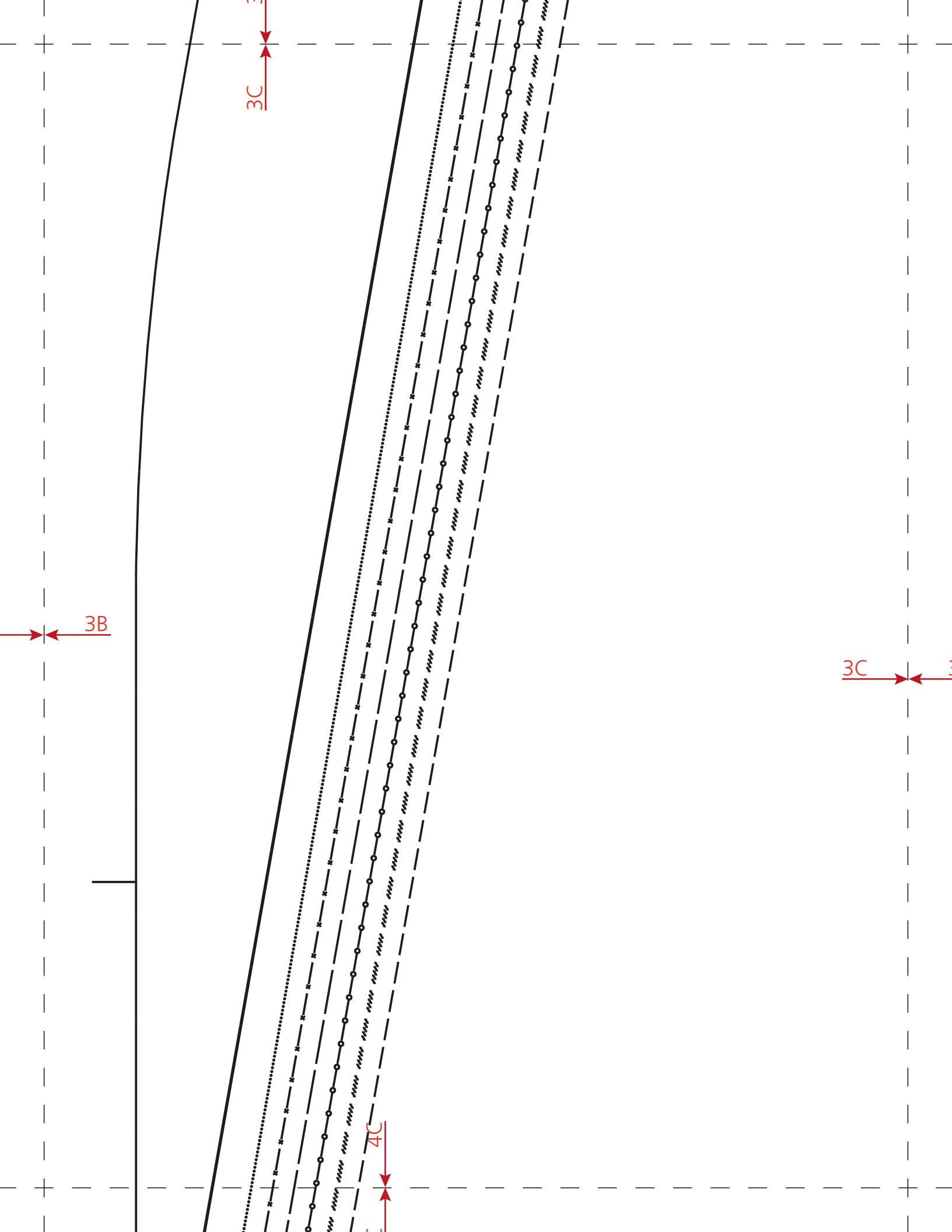

3B

3C

4C

3C

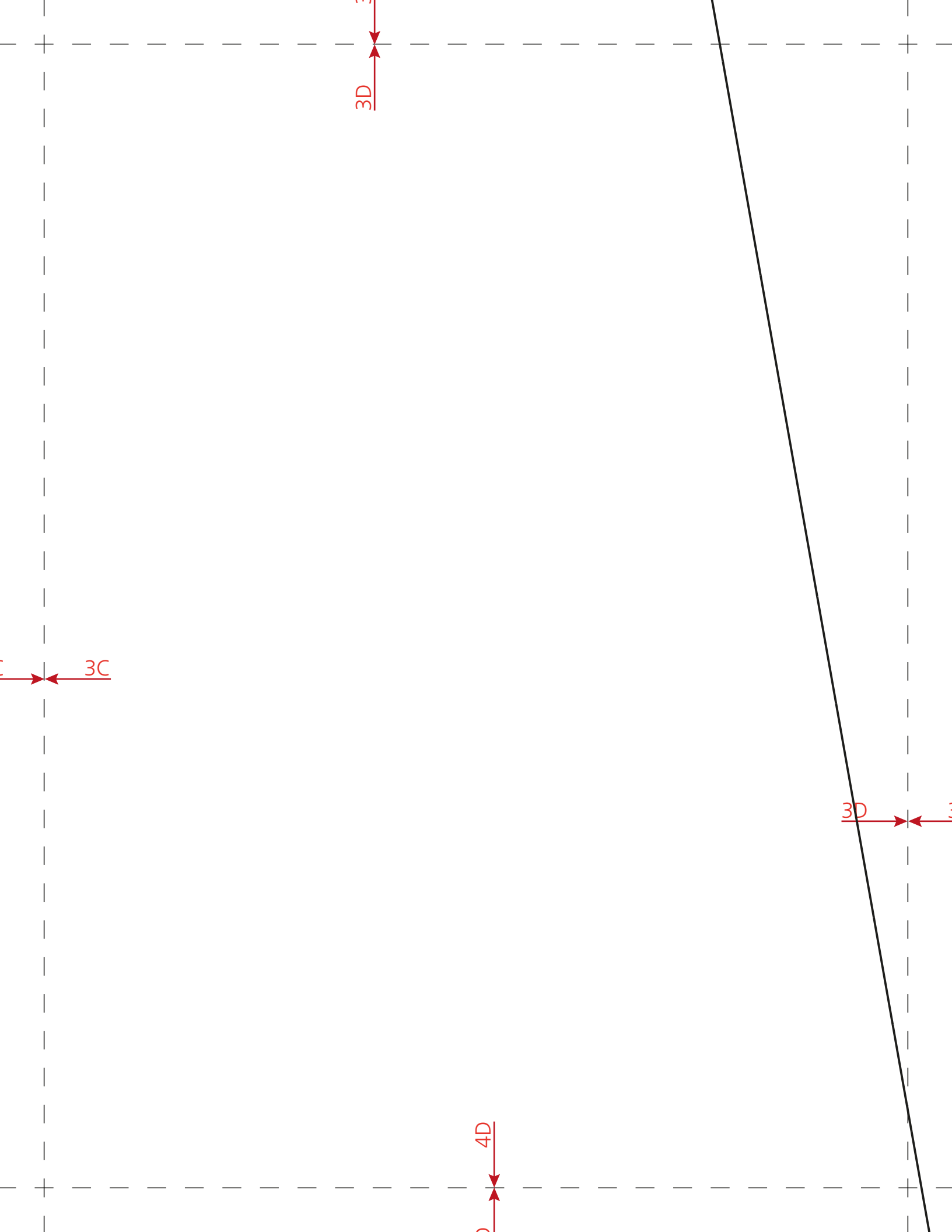

3E

Keine Inspiration mehr versäumen – mit einem Abo!
No more missing inspiration – with a subscription!



Ja, ich möchte die Inspiration ab der nächsten Ausgabe für 1 Jahr abonnieren (3 Hefte pro Jahr).

Yes, I would like to subscribe to Inspiration from the next issue for 1 year (3 issues per year).

Jeweils im Januar erscheint das Frühjahrsheft, im Mai das Sommerheft und im September die Herbst/Winterausgabe. In allen Ausgaben sind Schnittmuster enthalten.

The spring issue is published in January, the summer issue in May and the autumn/winter issue in September. All issues contain pattern plans.

Land/ Country

Print

Digital (nur online buchbar/
bookable only online)

Sprache/ Language

Schweiz/ Switzerland

CHF 27

CHF 15

Deutsch/ German

Europa/ Europe

EUR 24,50

EUR 12

Englisch/ English

Übersee/ Overseas

USD 40/AUD 56

USD 16,50/AUD 25,50

Französisch/ French

alle Preise inkl. MwSt. und Porto/ All prices inclusive of VAT and postage

Niederländisch/ Dutch

Name

Geburtsjahr (optional)/ Year of birth (optional)

Strasse, Nr./ Street, no.

PLZ, Ort/ Postal code, town

Mein Abonnement beginnt mit der jeweils nächsten Ausgabe. Es läuft nach Erhalt von 3 Heften automatisch weiter, sofern ich nicht rechtzeitig vor Ablauf kündige.

Subscriptions normally begin with the next issue. Subscriptions are automatically renewed after 3 issues if not cancelled in time before their expiry.

Ich bin damit einverstanden, dass BERNINA meine Daten zur Weiterverarbeitung an Dritte (insb. die medienwerkstatt ag, Schweiz) übermittelt, sofern dies erforderlich ist, um die vertragliche Leistung in Anspruch nehmen zu können.

I agree that BERNINA may transfer my data to third parties (esp. the media workshop AG, Switzerland and Datatrans AG, Switzerland), if this is required in order to make use of the contractual service.

Ich bin damit einverstanden, dass meine Daten für Zwecke der Direktwerbung von BERNINA verarbeitet und mit anderen Informationen, die von BERNINA für denselben Zweck erhoben wurden, verknüpft werden. Weitere Informationen kann ich in der Datenschutzerklärung (bernina.com) einsehen. Diese Einwilligung kann ich jederzeit kostenfrei widerrufen.

I agree that my data will be processed for direct marketing purposes by BERNINA and will be linked with other information which have been collected by BERNINA for the same purpose. I can find further information in the privacy policy (bernina.com). I can revoke this consent free of charge at any time.

BERNINA International AG, Redaktion Inspiration, CH-8266 Steckborn, www.inspiration.bernina.com
 E-Mail: inspiration@bernina.com

3E

3D

4E

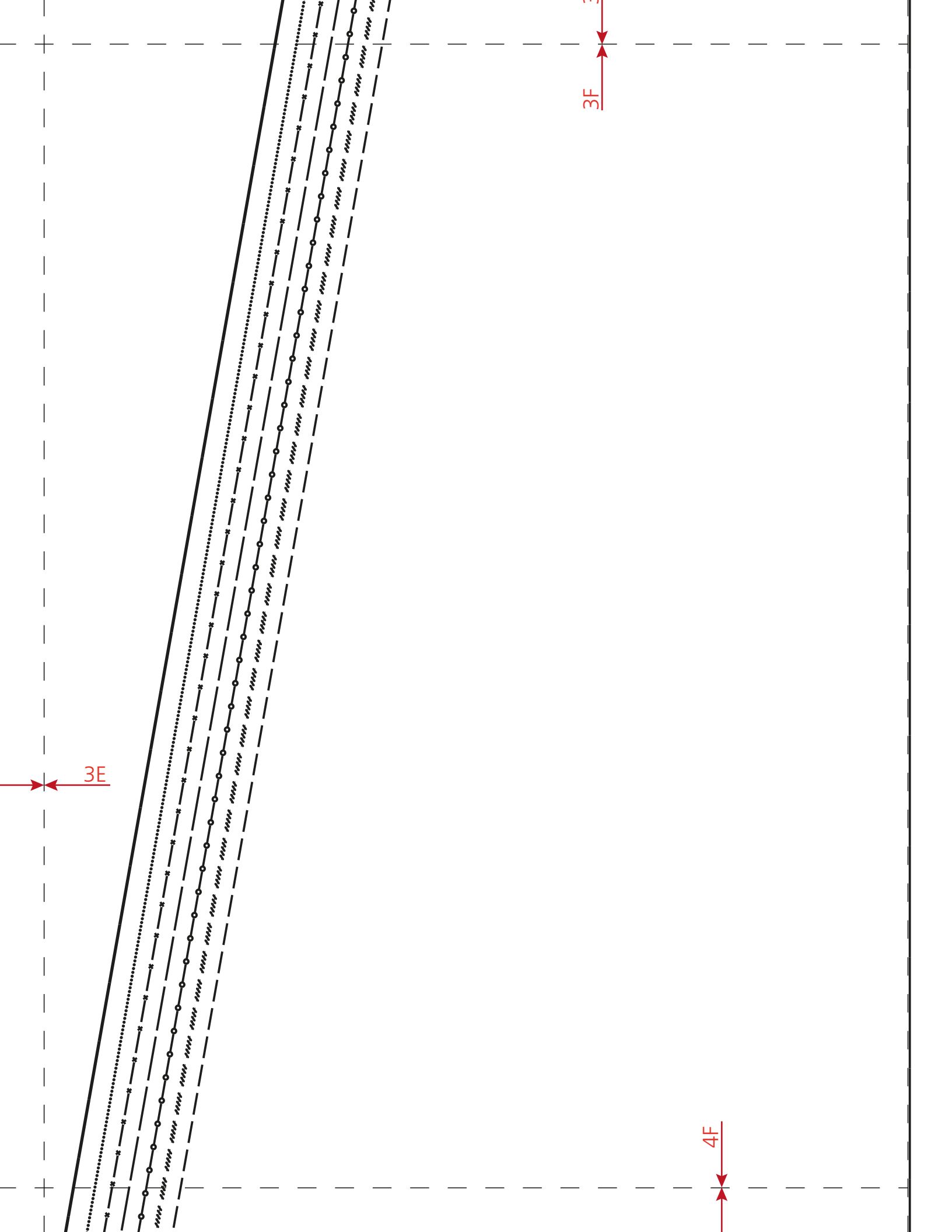

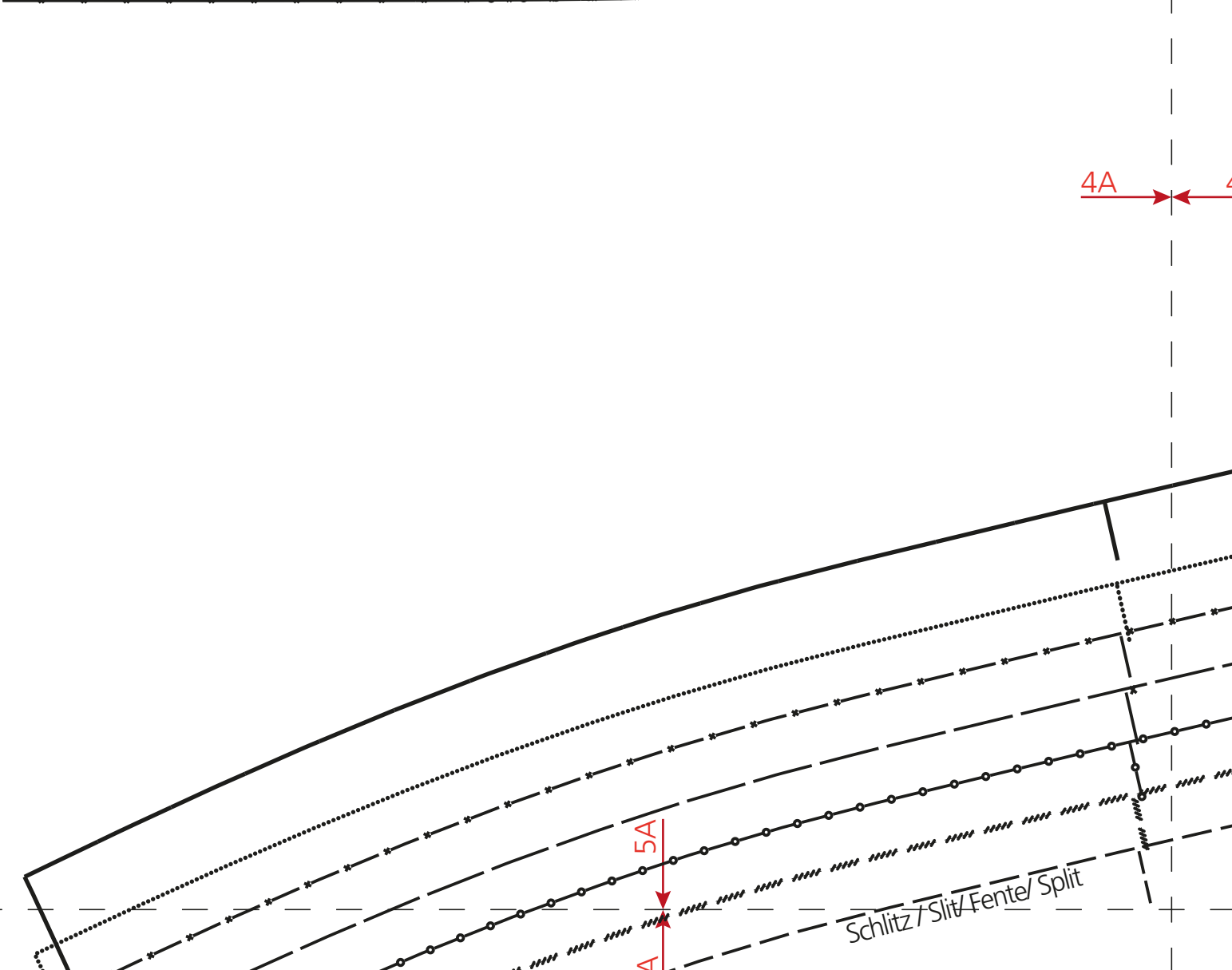
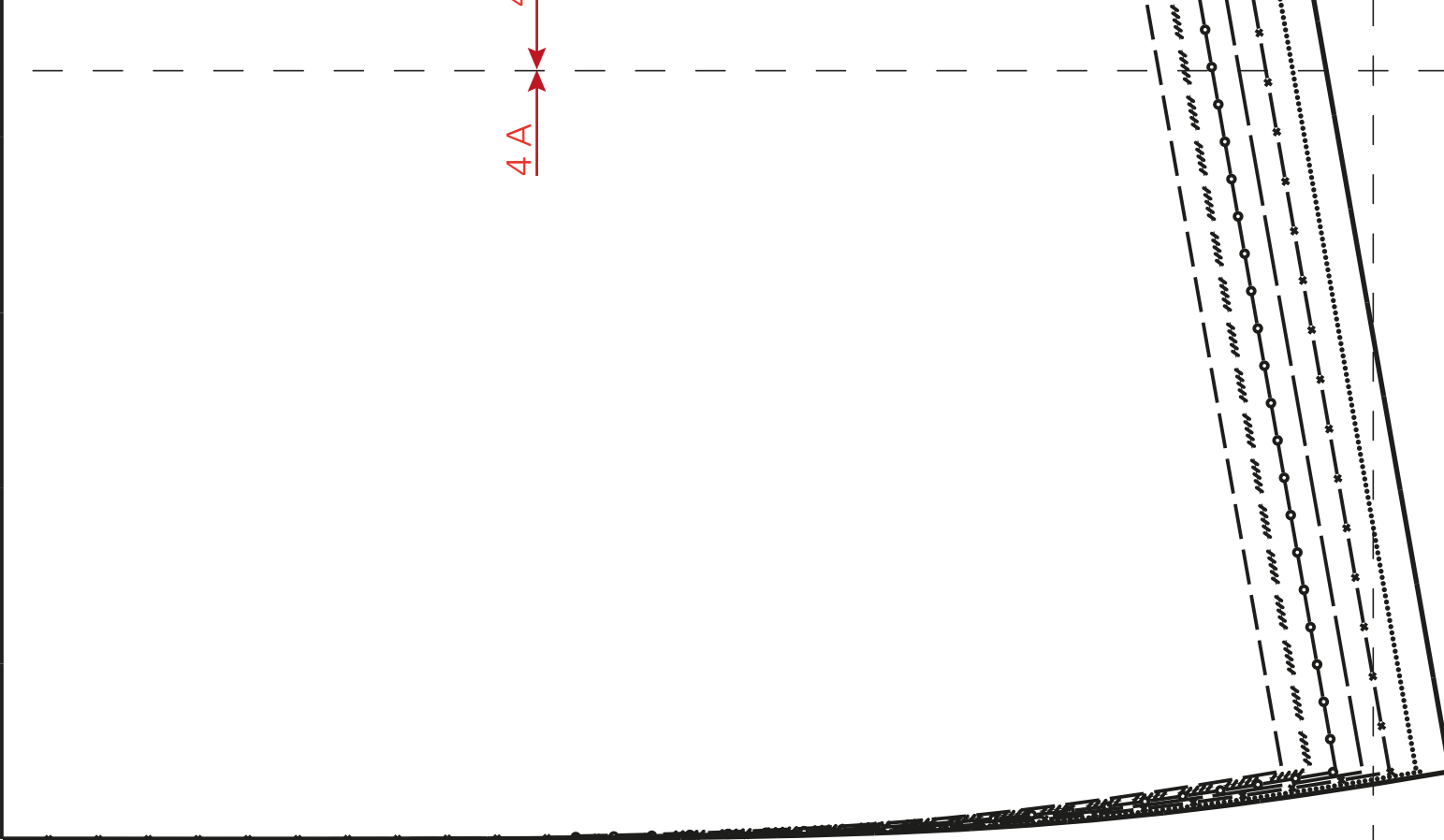

Fadenlauf/ Straight grain/ Droit fil/ Draadrichting

4B

Reissverschluss/ Zipper/ Fermeture à glissière/ Ritsluiting

4B

4A

Schlitz / Slit/ Fente/ Split

5B

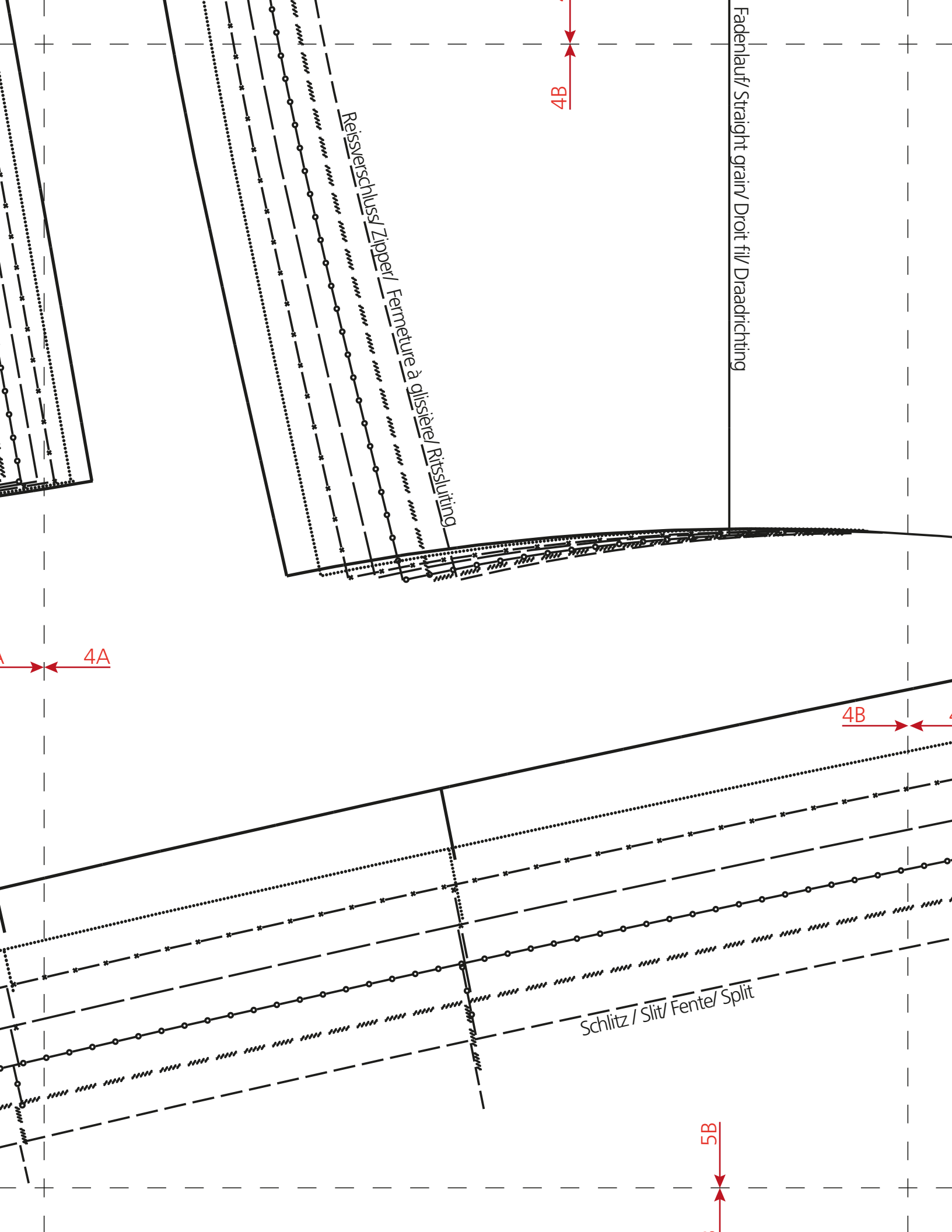

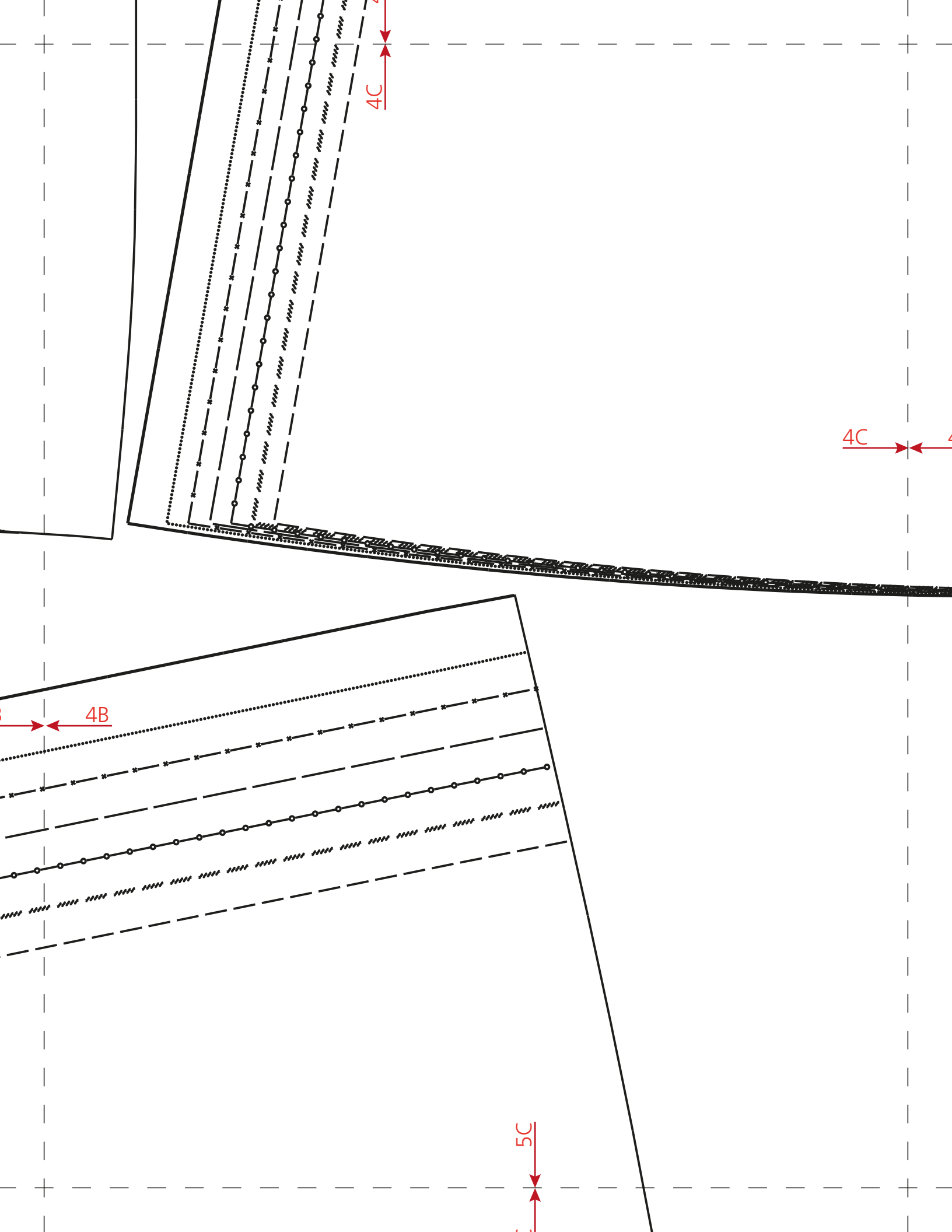

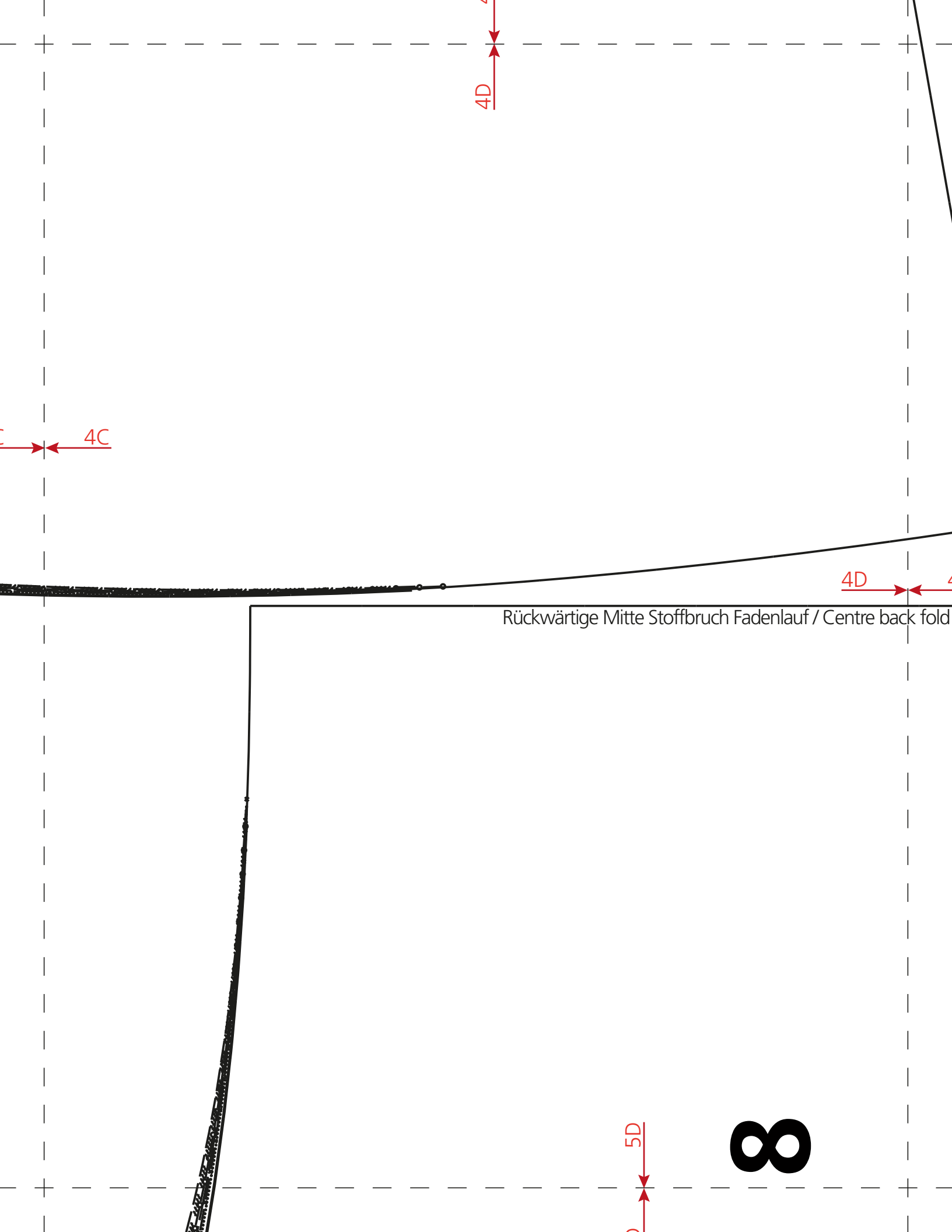

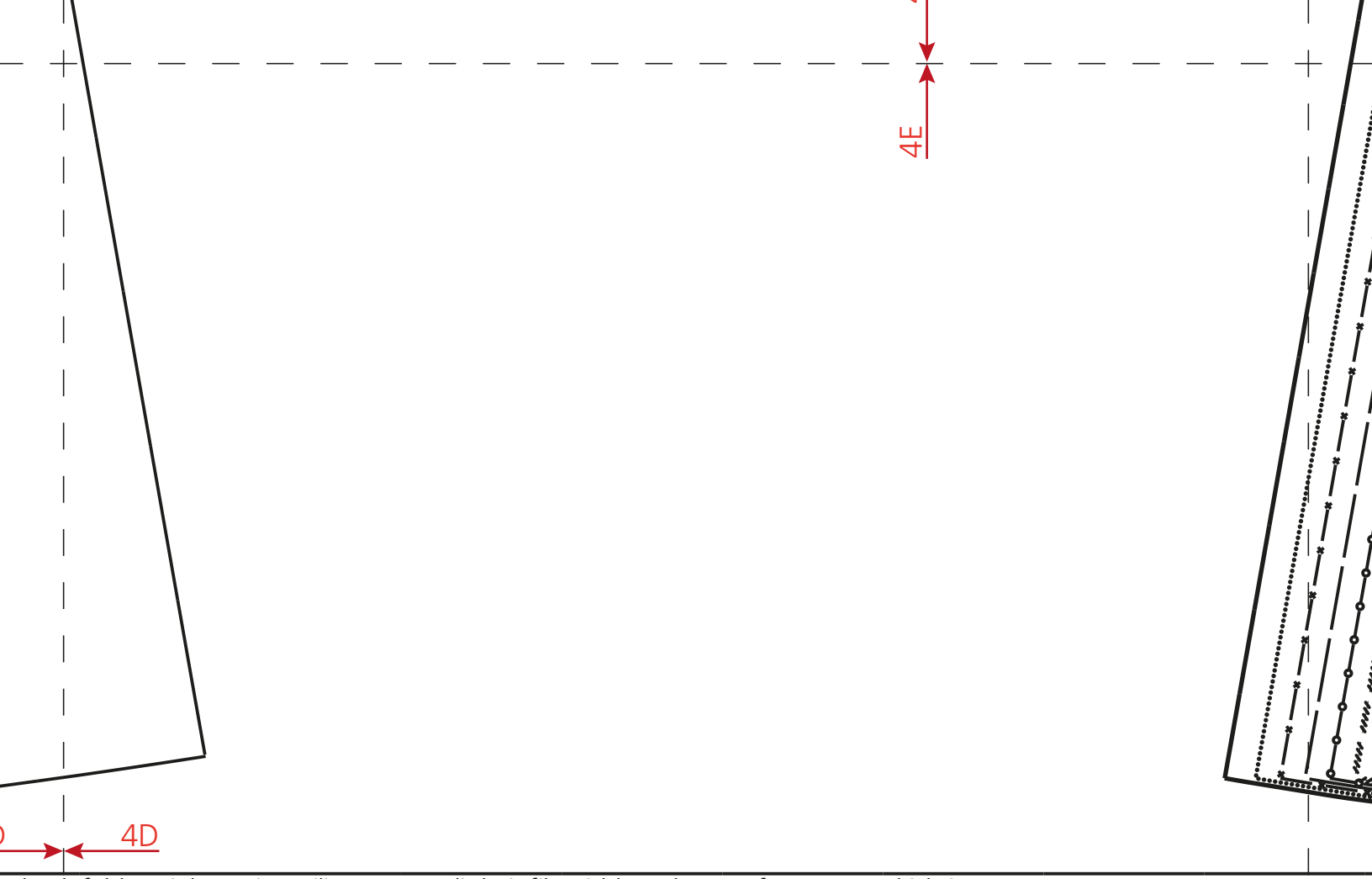

re back fold straight grain/ Milieu envers pli droit fil/ Middenachter stofvouw Draadrichting



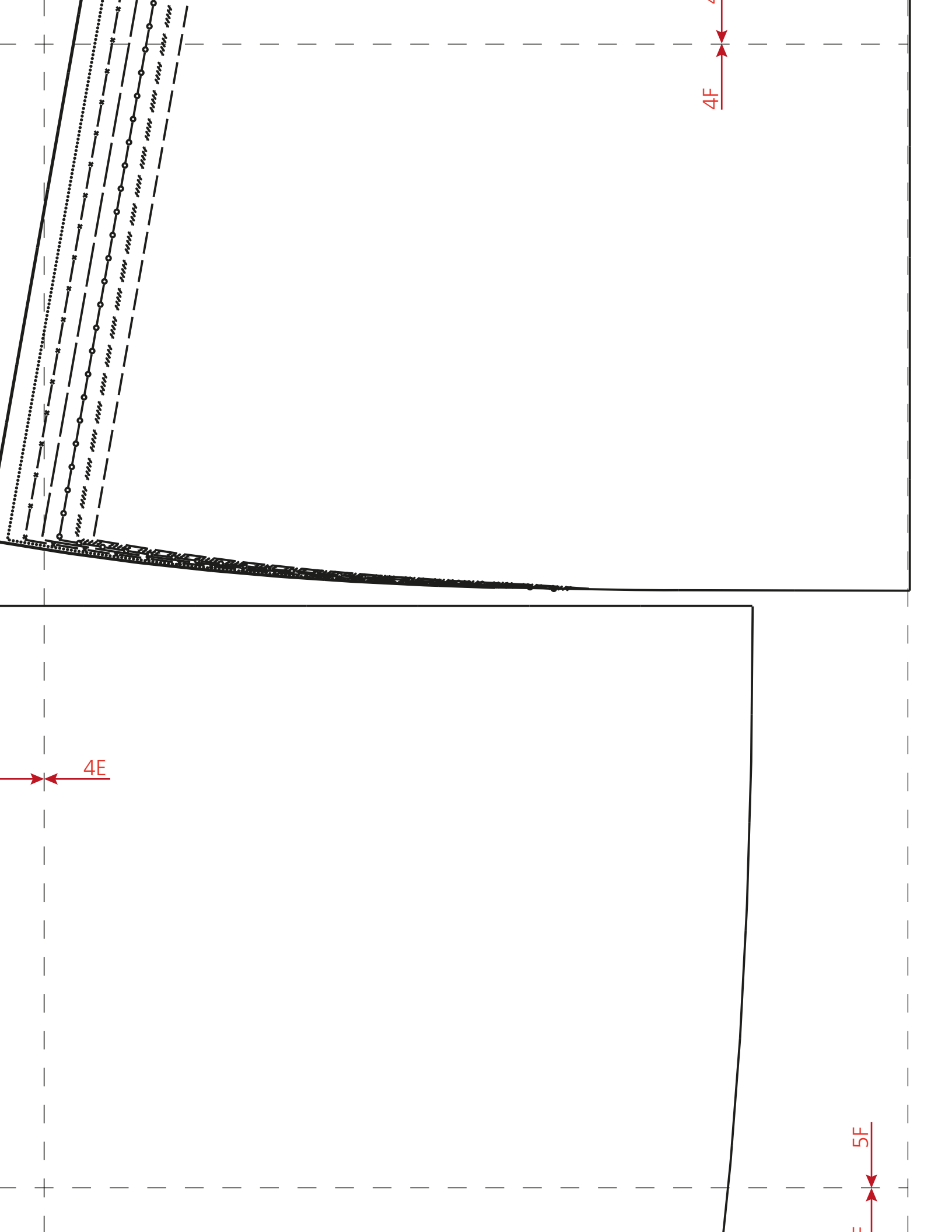

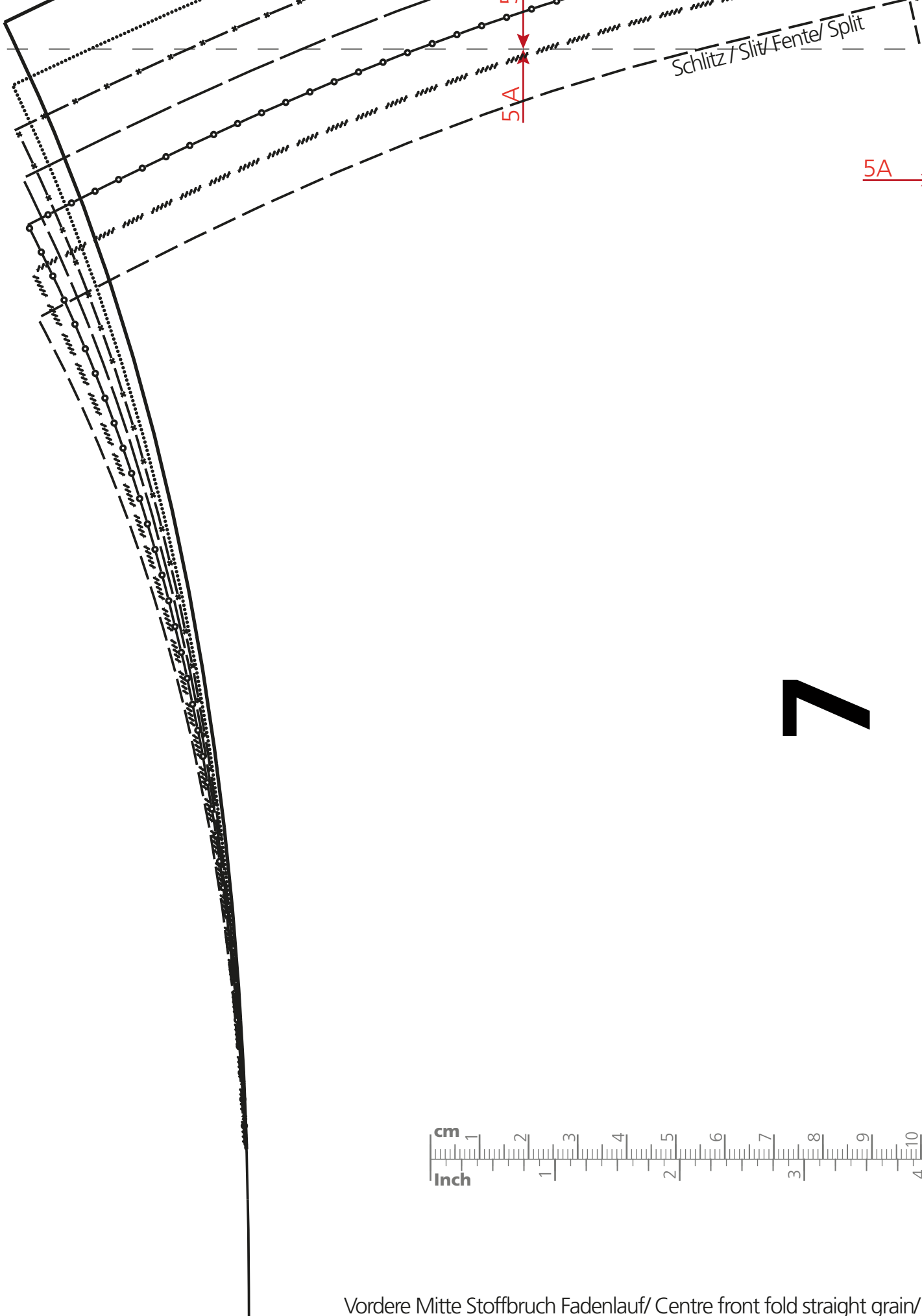

Schlitz / Slit / Fente / Split

7



Vordere Mitte Stoffbruch Fadenlauf / Centre front fold straight grain / Milieu e

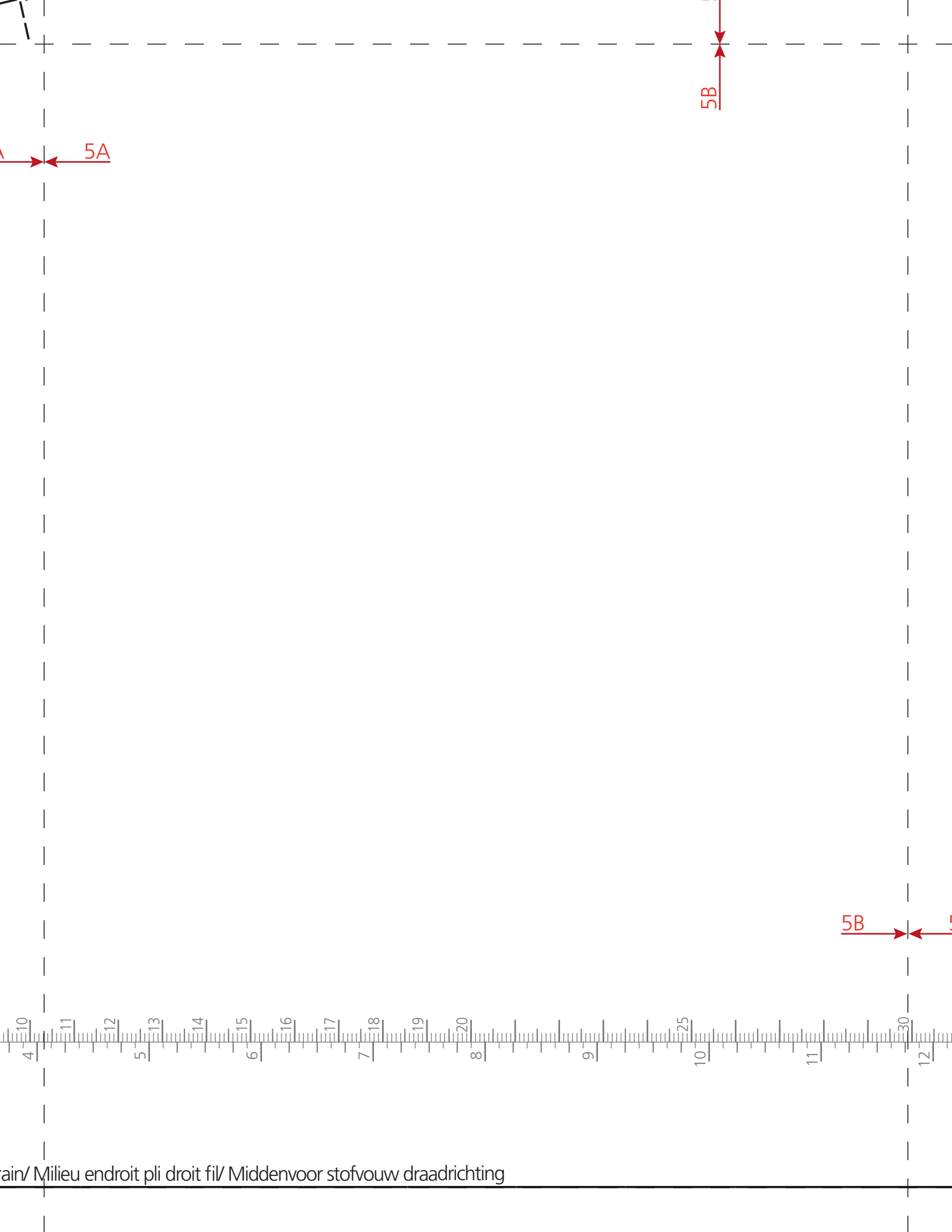

5A

5B

5B

ain/ Milieu endroit pli droit fil/ Middenvoor stofvouw draadrichting

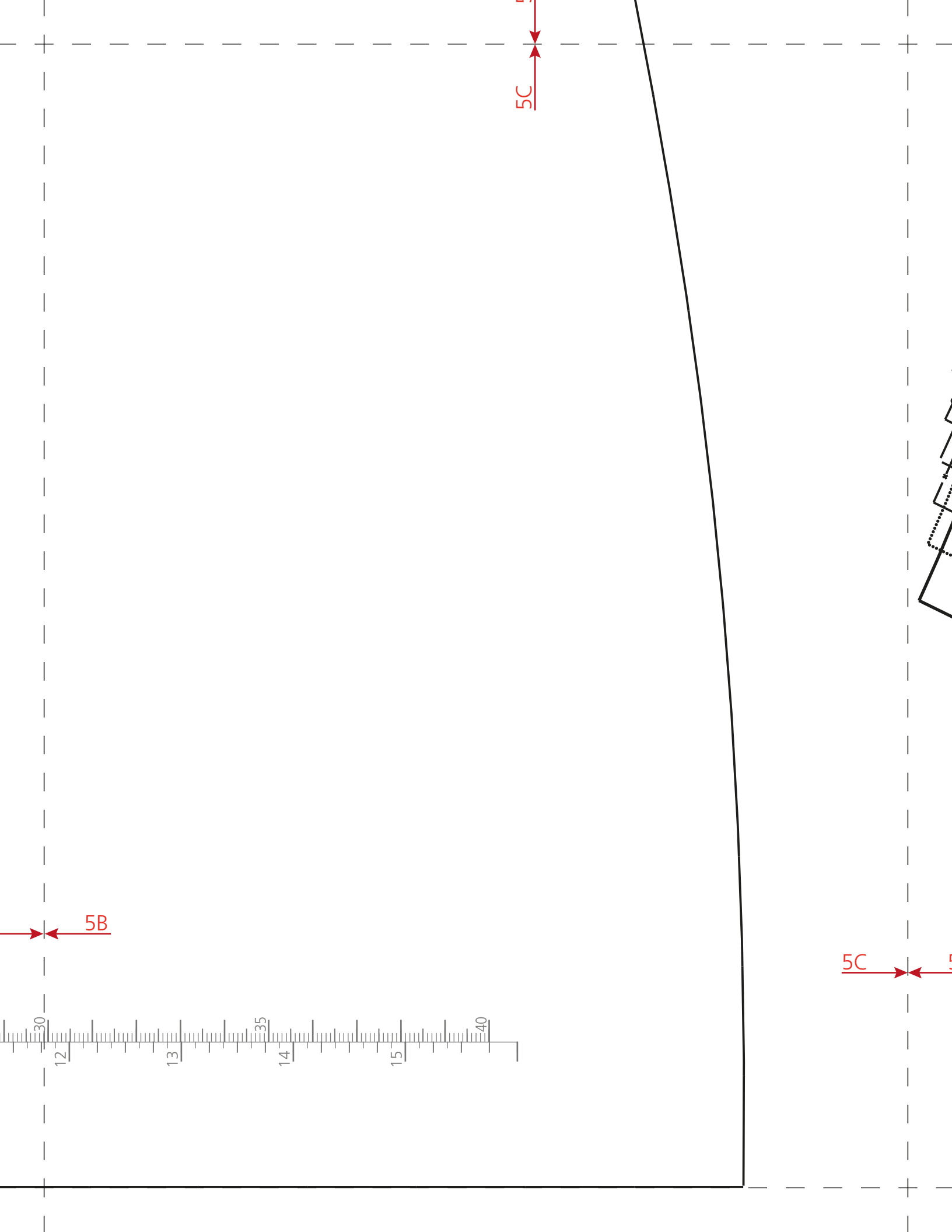

5D

5D

5C

