

Threading the upper thread directly from the spool to the needle

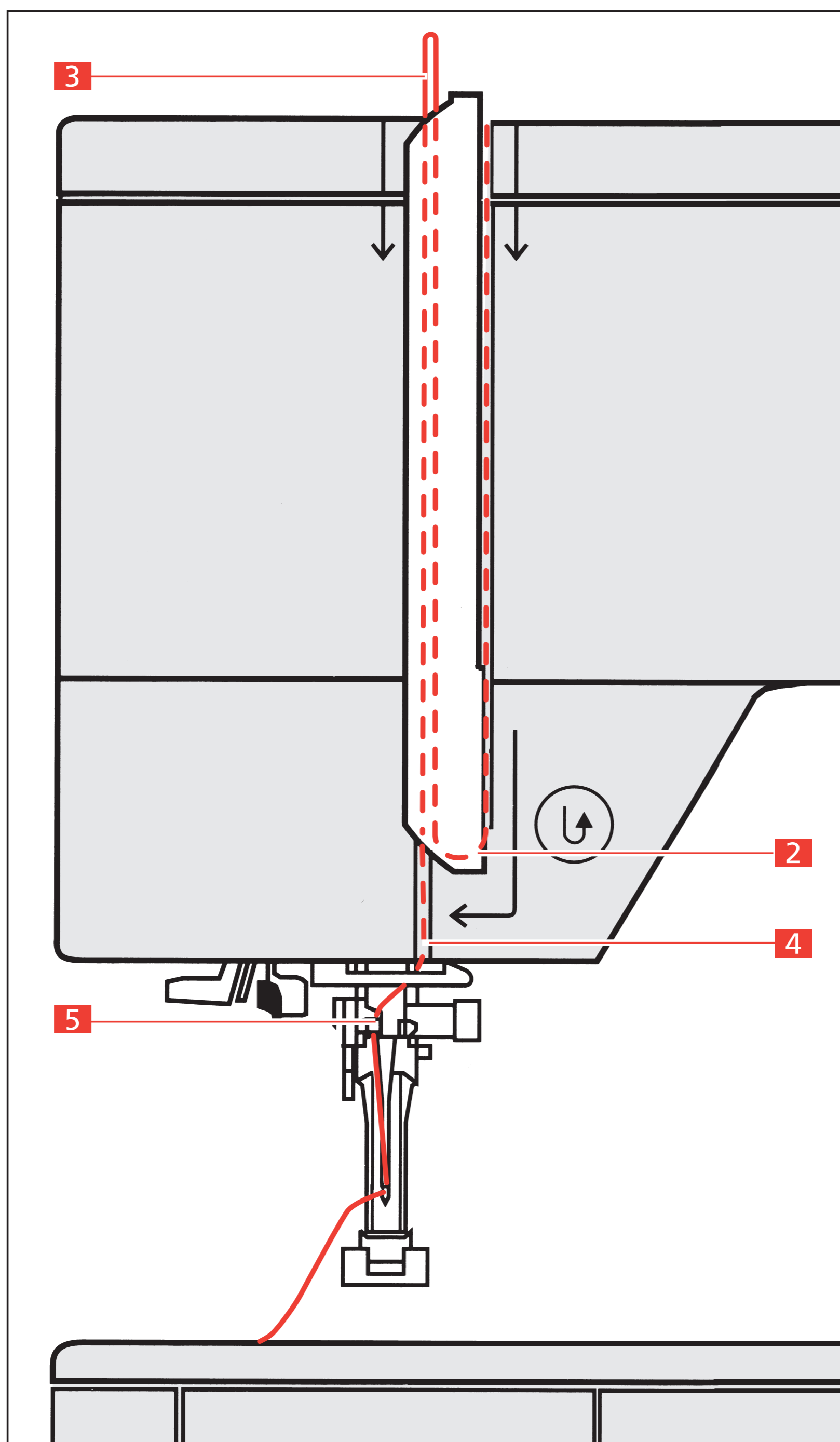
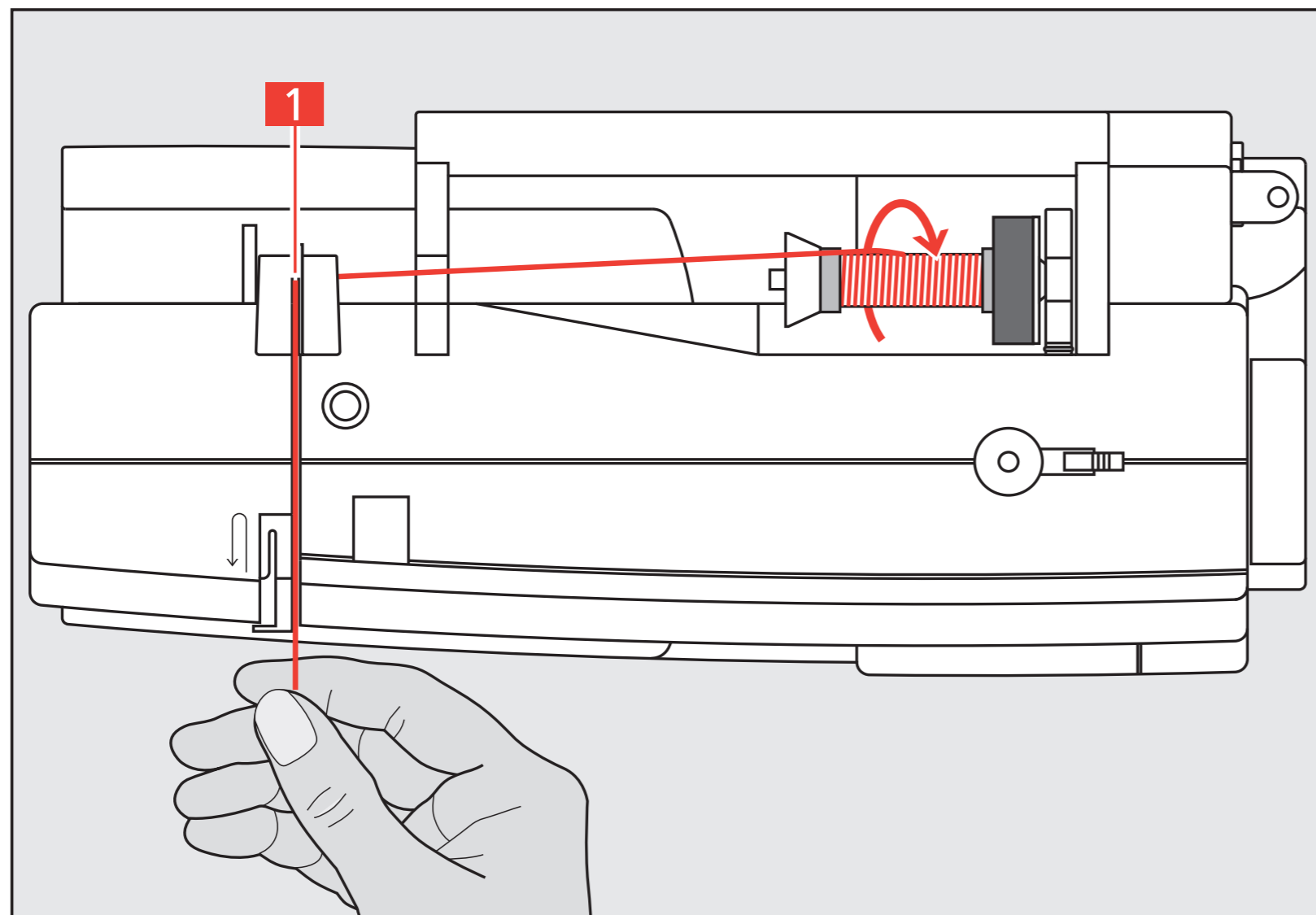

Instructions

1. Raise presser foot and needle.
2. Switch the power switch to «0» (Off).
3. Attach the foam pad.
4. Place spool on pin.
5. Place appropriate spool cap on spool.
(diameter of spool determines disc size)
6. Take thread through rear guide **1**.
7. Pull thread into thread tension slit.
8. Pull the thread down on the right of the take-up cover to point **2**, then up on the left and into the slot on the take-up lever **3**.
9. Pull the thread down and thread it through guides **4** and **5**.
10. Thread the needle.