

Belts & Belt Loops

Belts

Fold fabric strip right sides together. Beginning in the middle of one long side, stitch to one end. Beginning about 10cm from the previous starting point, stitch to the other long end. Grade seam allowance and clip curves and corners as needed.

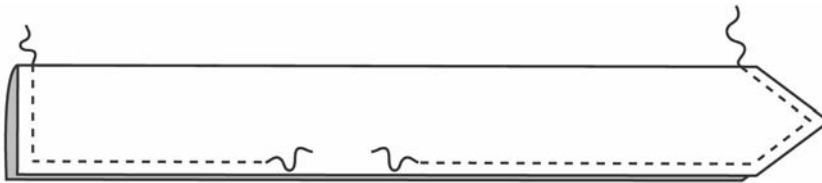

Turn belt right side out through opening in long side. Press. Edgestitch entire outer edge of belt; opening will be stitched closed at the same time. If desired, topstitch 7mm inside edgestitching.

Make eyelets at indicated positions, or apply grommets following manufacturer's instructions.



► **Tip:** If your sewing machine has pre-programmed eyelets, use them to stitch the eyelets on your belt. Another option is an eyelet embroidery set (BERNINA Eyelet Embroidery Set #82 with Foot #92).

Attach belt buckle according to manufacturer's instructions.

► **Tip:** Most belt buckles are attached by folding one end of the belt around the bar in the middle of the buckle, then stitching or bartacking the end in place.

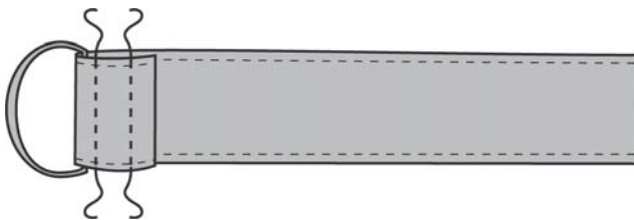

Making Belt Loops

Overlock one long edge of belt loop strip. Fold strip into thirds, overlapping raw edges at the center of the strip. Edgestitch both long sides.

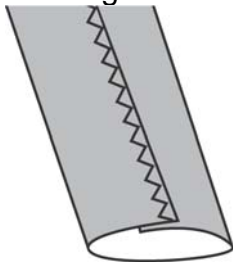

- **Tip:** *Instead of edgestitching, sew a decorative stitch through the center of the folded strip.*

Cut into required lengths.

Alternate Method

This technique is effective for heavy fabrics. Fold the strip in half, wrong sides together. Using a blind stitch and a blind hem foot (BERNINA Blindstitch Foot #5), stitch along the raw edges, catching the fabric in the zigzag portion of the stitch, letting the straight stitches sew “in air.” Refold with the stitching at the center back of the strip; press. Topstitch.

Attaching Belt Loops

Two Piece Waistband (Pants, Skirts)

Insert belt loops between waistband and waistband facing, right sides of belt loops to right side of waistband, at markings. Stitch waistband-to-facing seam; upper edges of belt loops will be secured in stitching.

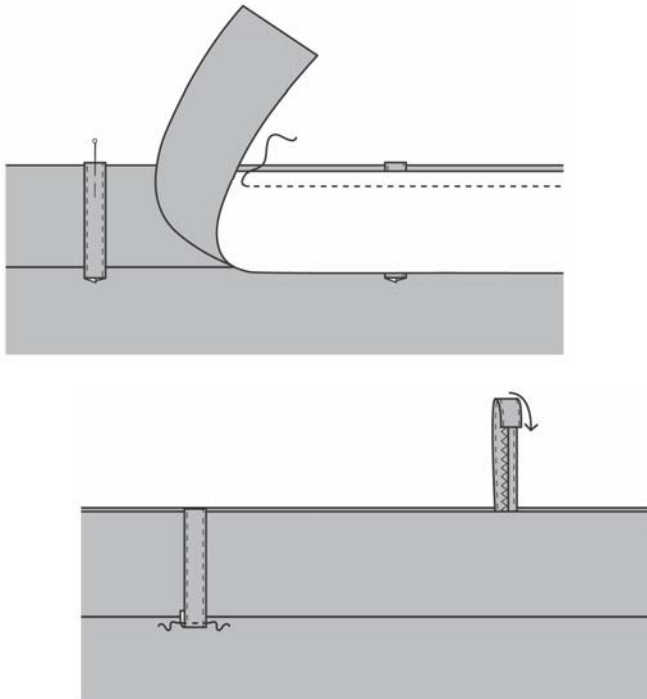

When waistband is complete, flip belt loops down, turn ends under, and edgestitch or bartack ends in place.

One Piece Waistband (Pants, Skirts)

Insert belt loops between waistband and waistline of garment, right sides of belt loops to right waistband, at markings. Stitch waistband-to-garment seam; lower edges of belt loops will be secured in stitching.

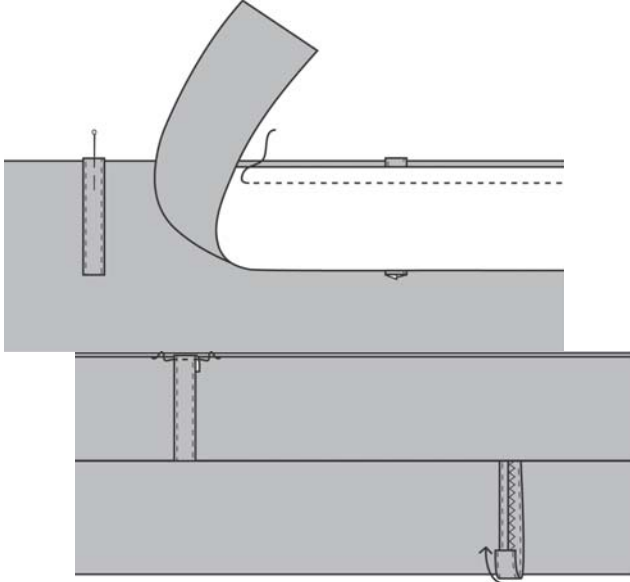

When waistband is complete, flip belt loops up, turn ends under, and edgestitch or bartack ends in place.

No Waistband (Jackets, Coats)

Position upper edges of belt loops over markings, right sides of belt loops to right side of garment, with opposite ends pointing away from the waistline (not over it). Position loops so that 1cm extends below markings. Stitch in place, 1cm from raw edge, backtacking to secure ends.

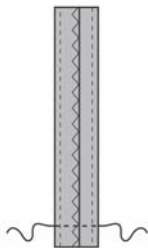

Flip loops down, turn ends under, and edgestitch or bartack ends in place.

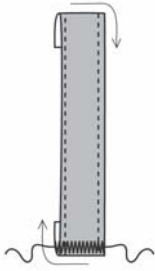

- ▶ **Tip:** Belt loops must be long enough to accommodate the width of the belt, plus seam allowances at the upper and lower edges, plus 6mm to 12mm extra ease depending on the thickness of the belt. It's better to cut them too long and clip off the excess later, than to cut them too short and have to make them over again later.
- ▶ **Tip:** Instead of fabric belt loops, substitute ribbon or trim.

Thread Loops

Create strong thread chains for belt and button loops using several strands of thread and a zigzag stitch. Cut several lengths of thread; hold them together and bind them together using a 2mm wide zigzag stitch, making sure all strands are encased in the stitching. Hold the strands from the front and back, guiding them under the foot.

- ▶ **Tip:** Insert the lengths of thread into the guide at the front of BERNINA Embroidery Foot #6 or Clear Embroidery Foot #39.

