

1

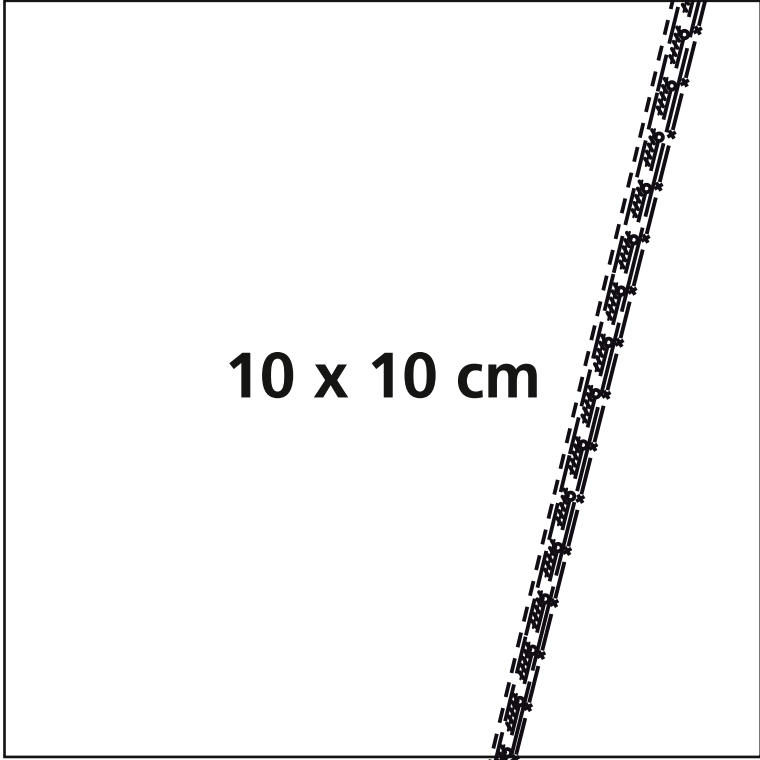

10 x 10 cm

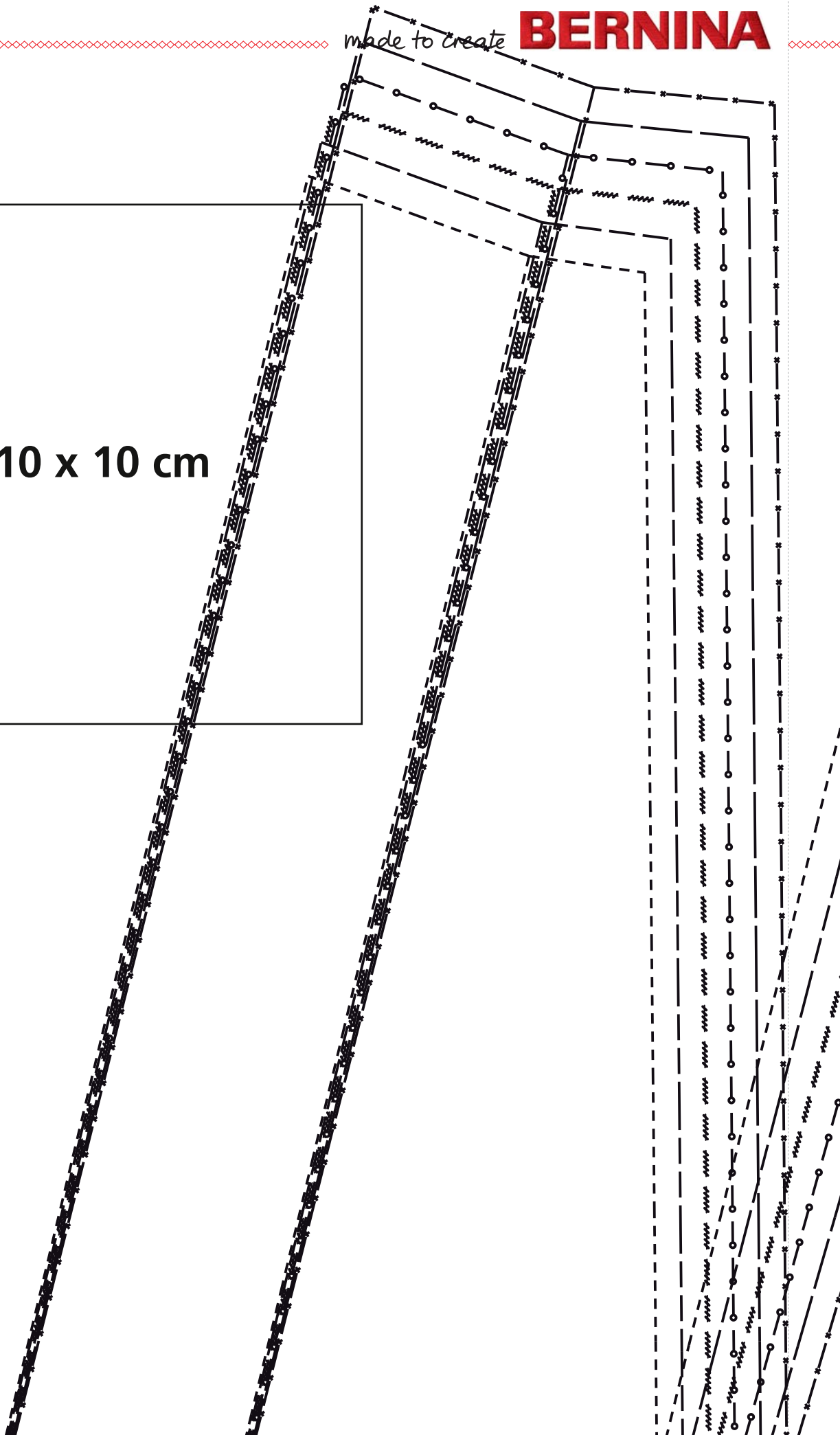

3

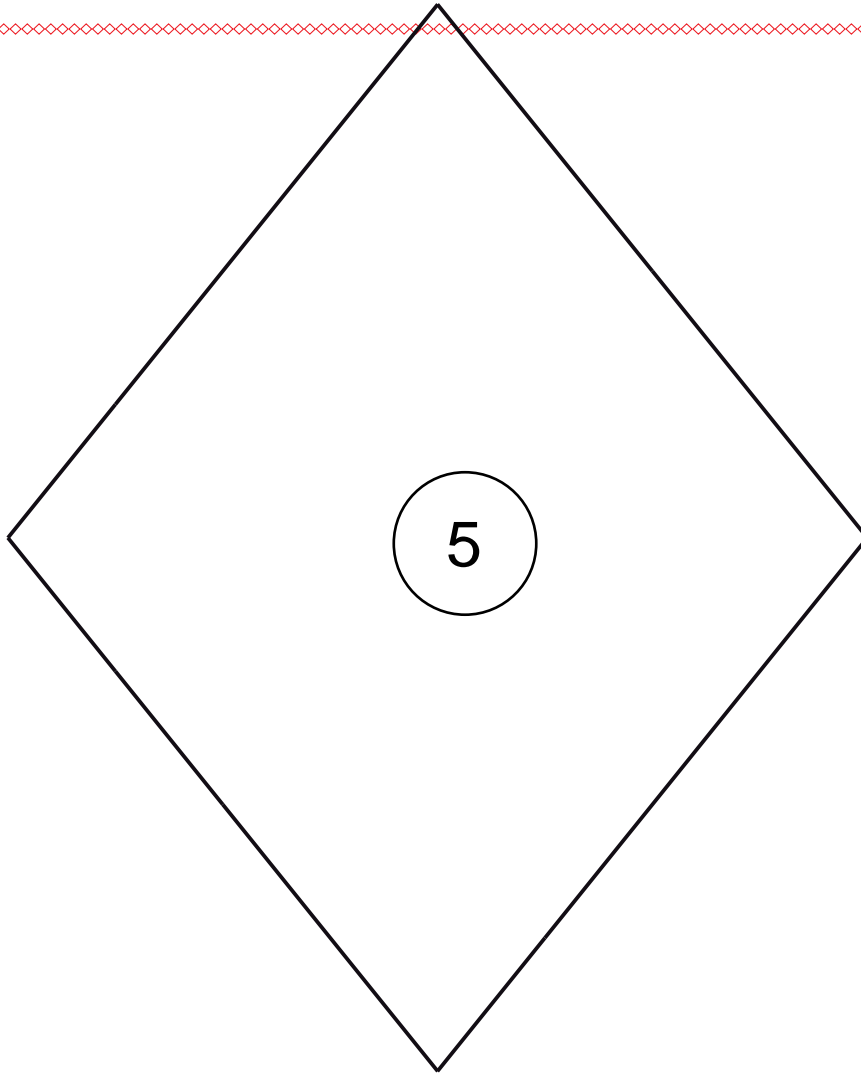

Für Körpergröße/ for height/ pour la taille/ Maten voor lichaamsgrootte 168 cm

Größe/ Size/ Taille/ Maat	34	36	38	40	42	44	46	48
Oberweite/Bust/ Poitrine/ Bovenwijdte	80	84	88	92	96	100	104	110
Tailenweite/ Waist/ Taille/ Taillewijdte	64	67	71	75	79	83	87	94
Hüftweite/ Hip/ Hanche/ Heupwijdte	90	93	96	99	102	105	108	114
Vord. Taillengl./ Front waist length/ Longueur taille devant/ Taillelengte voor	42	43	44	45	46	47	48	49
Rückw. Tailleng./ Back waist length/ Longueur taille dos/ Ruglengte tot taille	41	41	41	42	42	42	42	43

Legende/Legend/ Légend

Größe/	-----	34
Size/	-----	36
Taille/	-----	38
Maat	-----	40
	-----	42
	-----	44

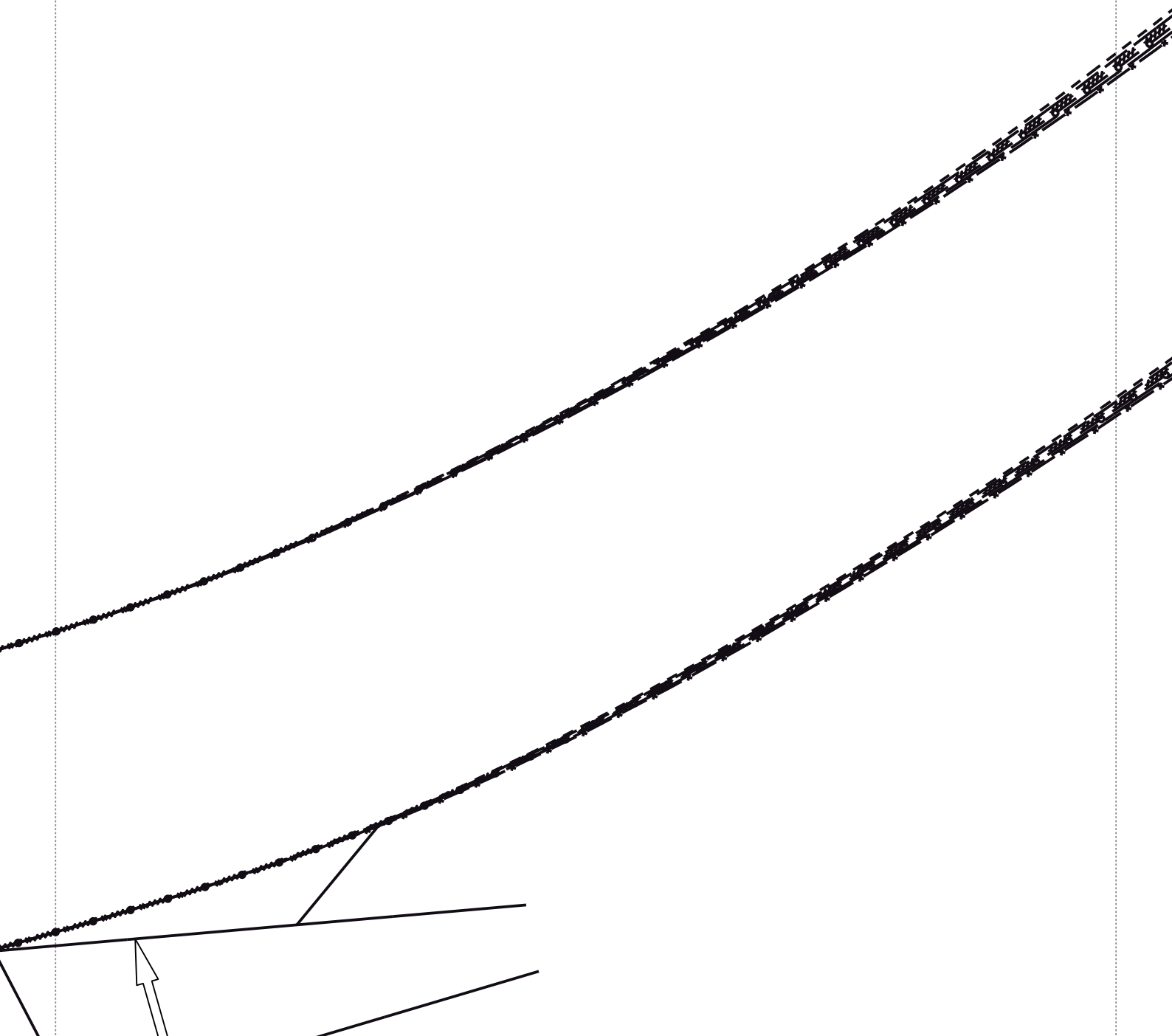

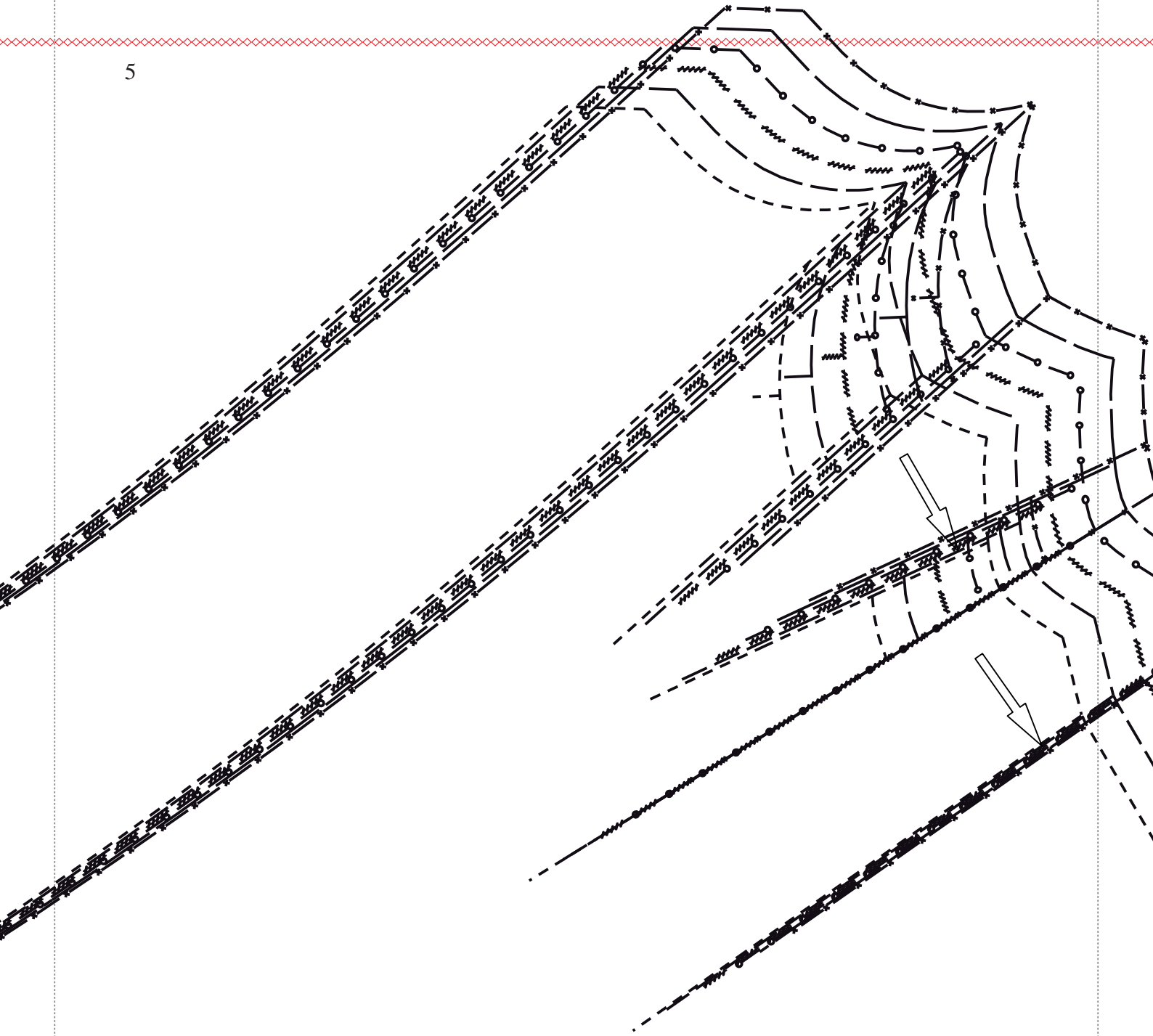



7

2

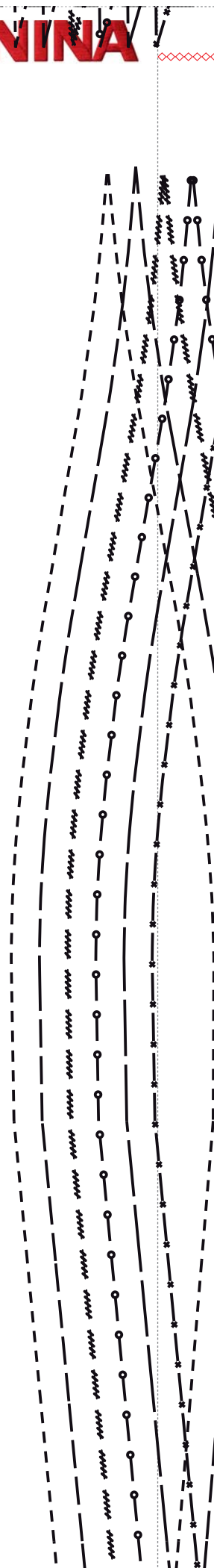
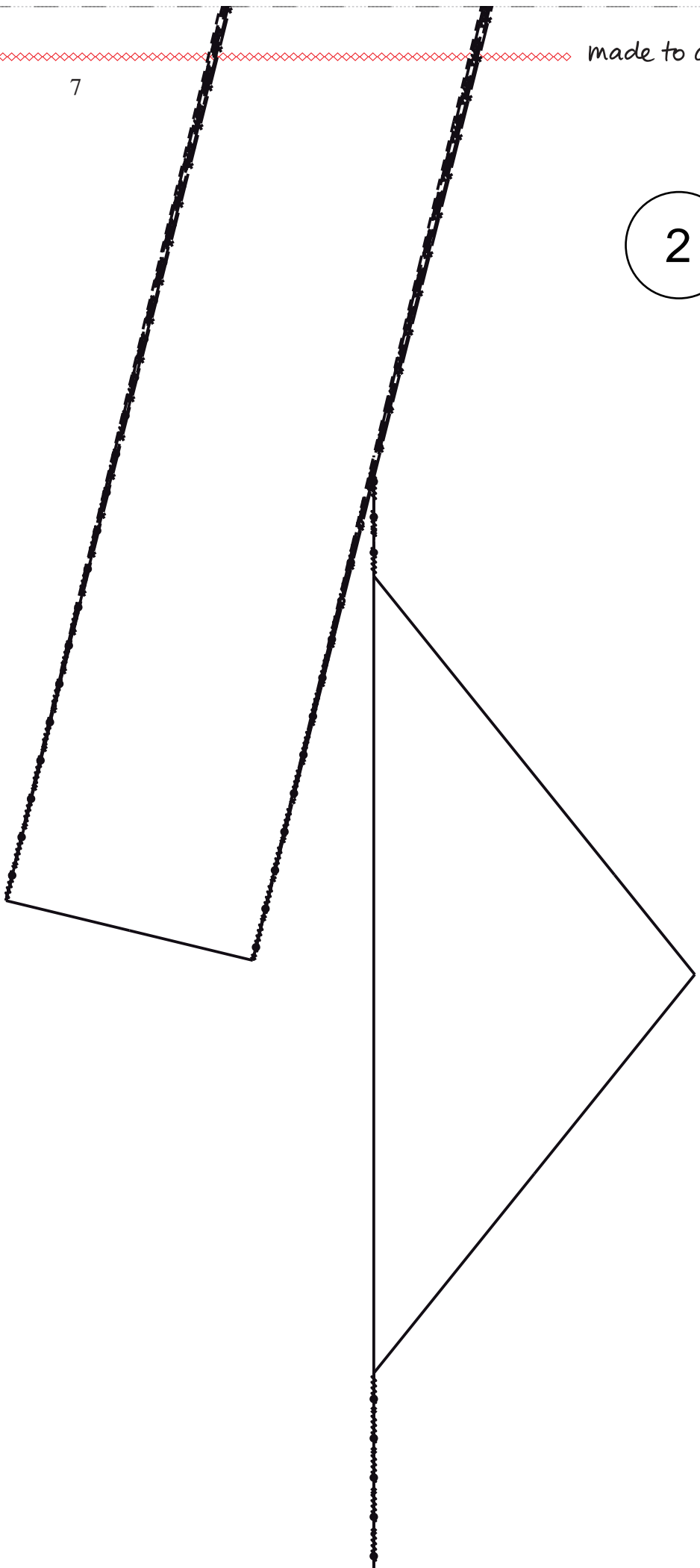

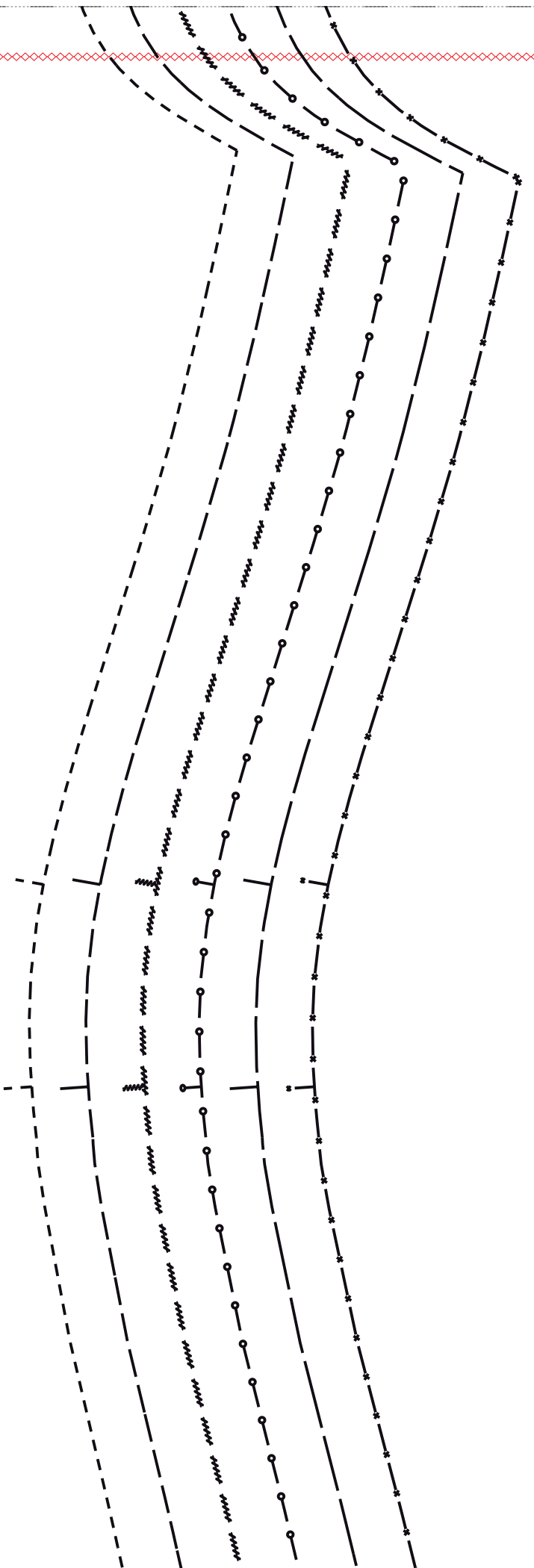
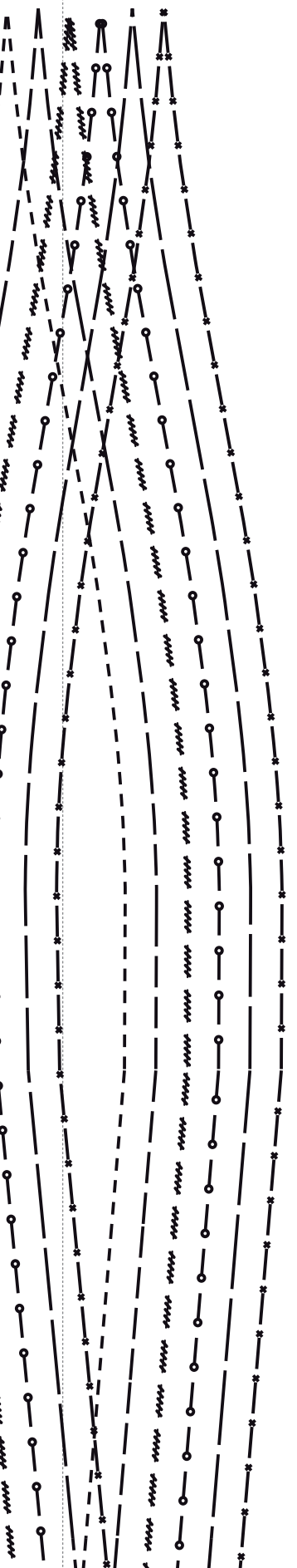

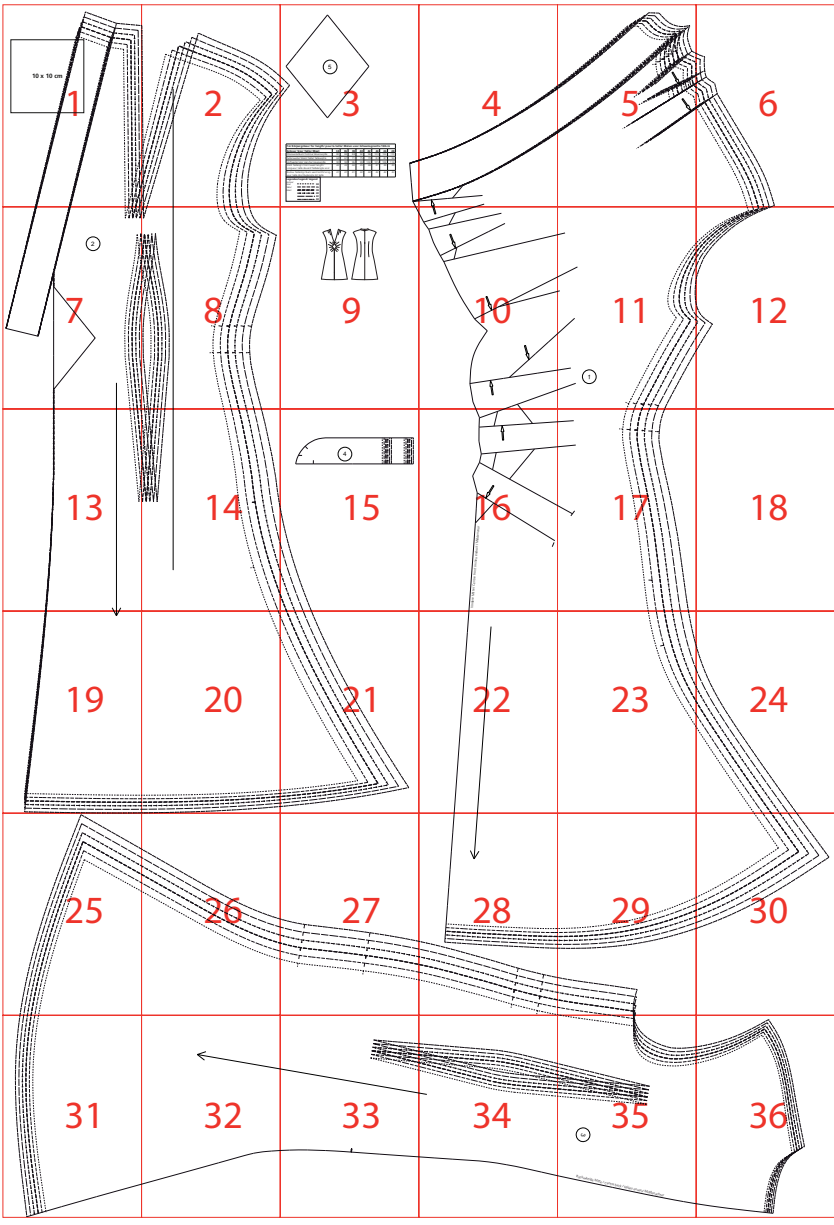
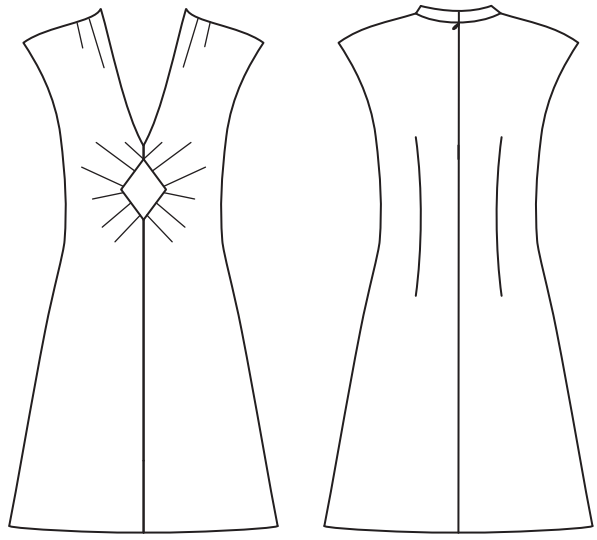

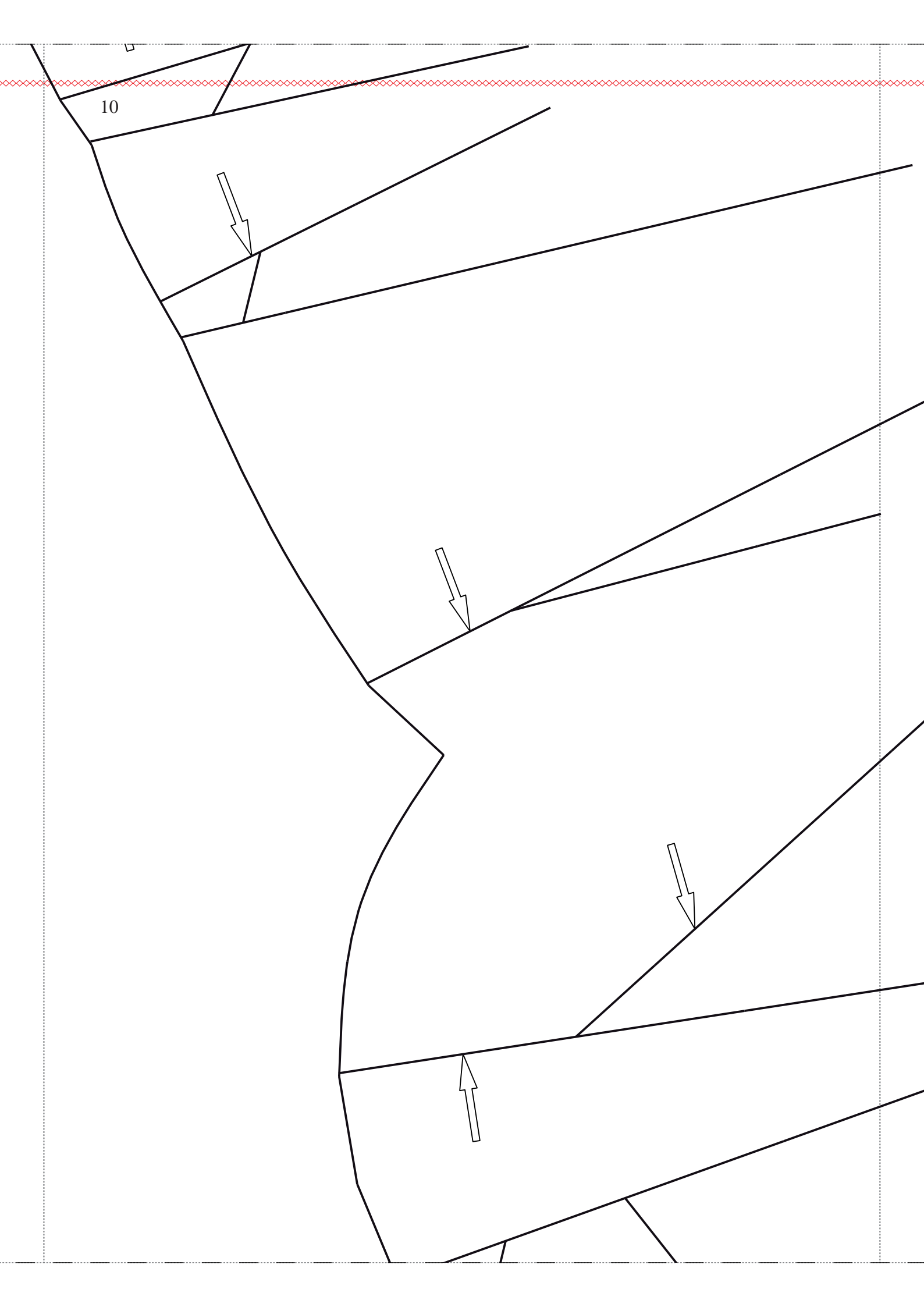

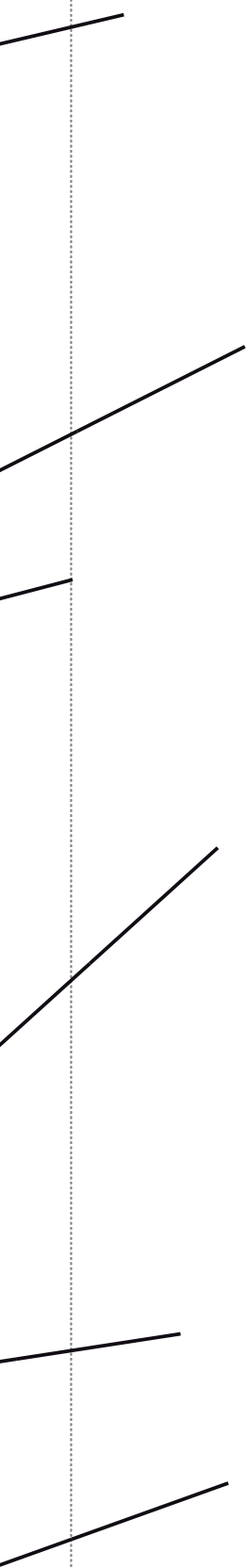

1

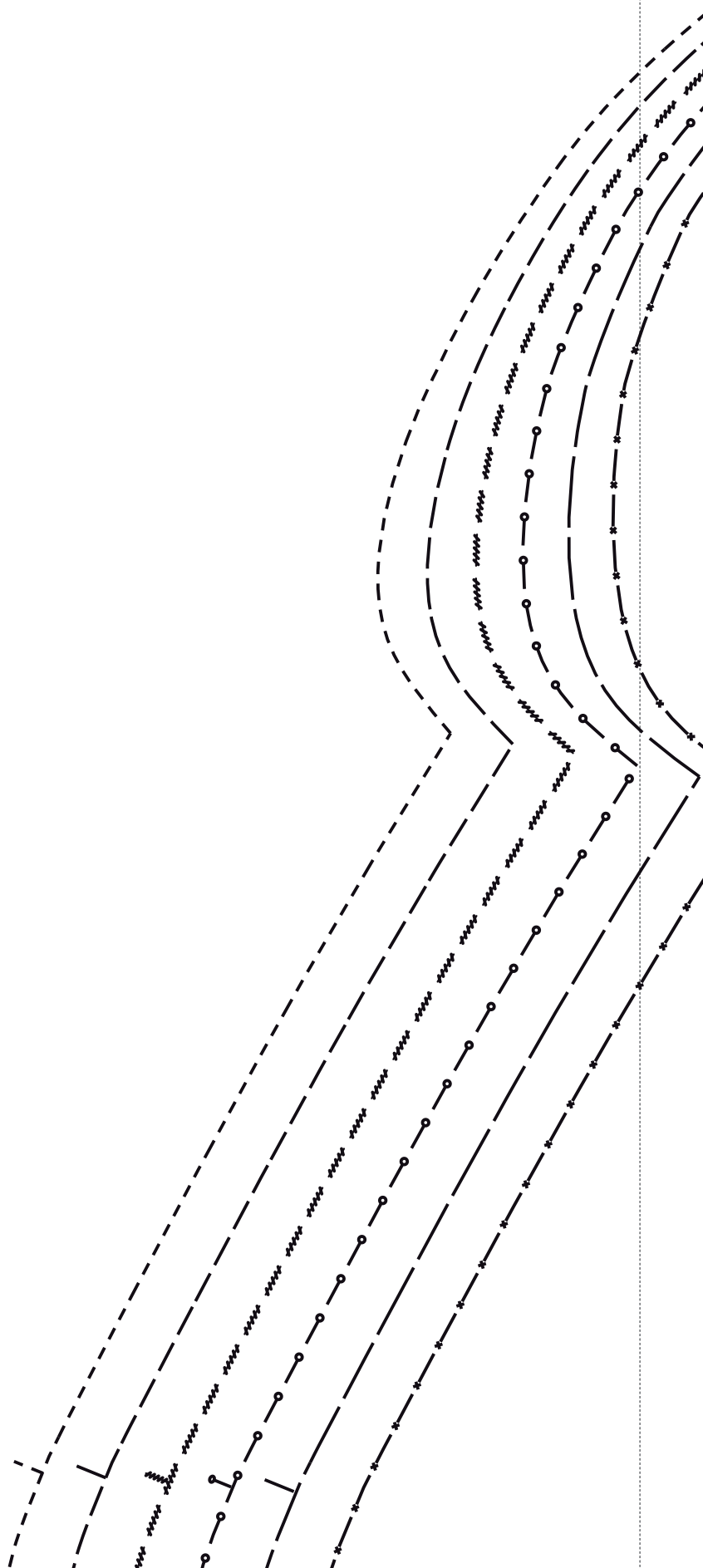

**4+1-Aktion: Zu Ihrem inspirations-
Abo schenken wir Ihnen eine Gratis-
Ausgabe!**



**Als Prämie erhalte ich ein Heft gratis, also statt der
4 Ausgaben eines Abonnements erhalte ich 5.**

► ICH ABONNIERE DIE INSPIRATION FÜR 1 JAHR (4 AUSGABEN)

- | | | | |
|------|---|---------|---|
| Land | <input type="checkbox"/> Schweiz 29 CHF | Sprache | <input type="checkbox"/> Deutsch |
| | <input type="checkbox"/> Europa 24 EURO | | <input type="checkbox"/> Englisch |
| | alle Preise inkl. MwSt. und Porto | | <input type="checkbox"/> Französisch |
| | | | <input type="checkbox"/> Niederländisch |

Name

Geburtsjahr

Strasse, Nr.

Plz, Ort

Telefon

E-Mail

**Mein Abonnement beginnt mit der nächste inspirations-Ausgabe. Es
läuft nach Erhalt von 5 Heften automatisch weiter, sofern ich nicht
rechtzeitig vor Ablauf kündige.**

**BERNINA International AG, Redaktion Inspiration, CH-8266 Steckborn
Fax +41 52 762 13 12, E-Mail: redaktion@bernina.com**

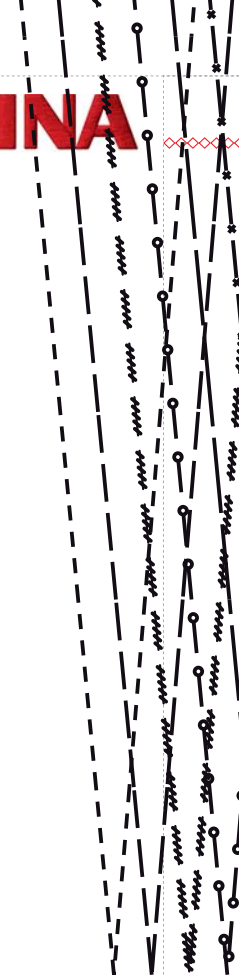

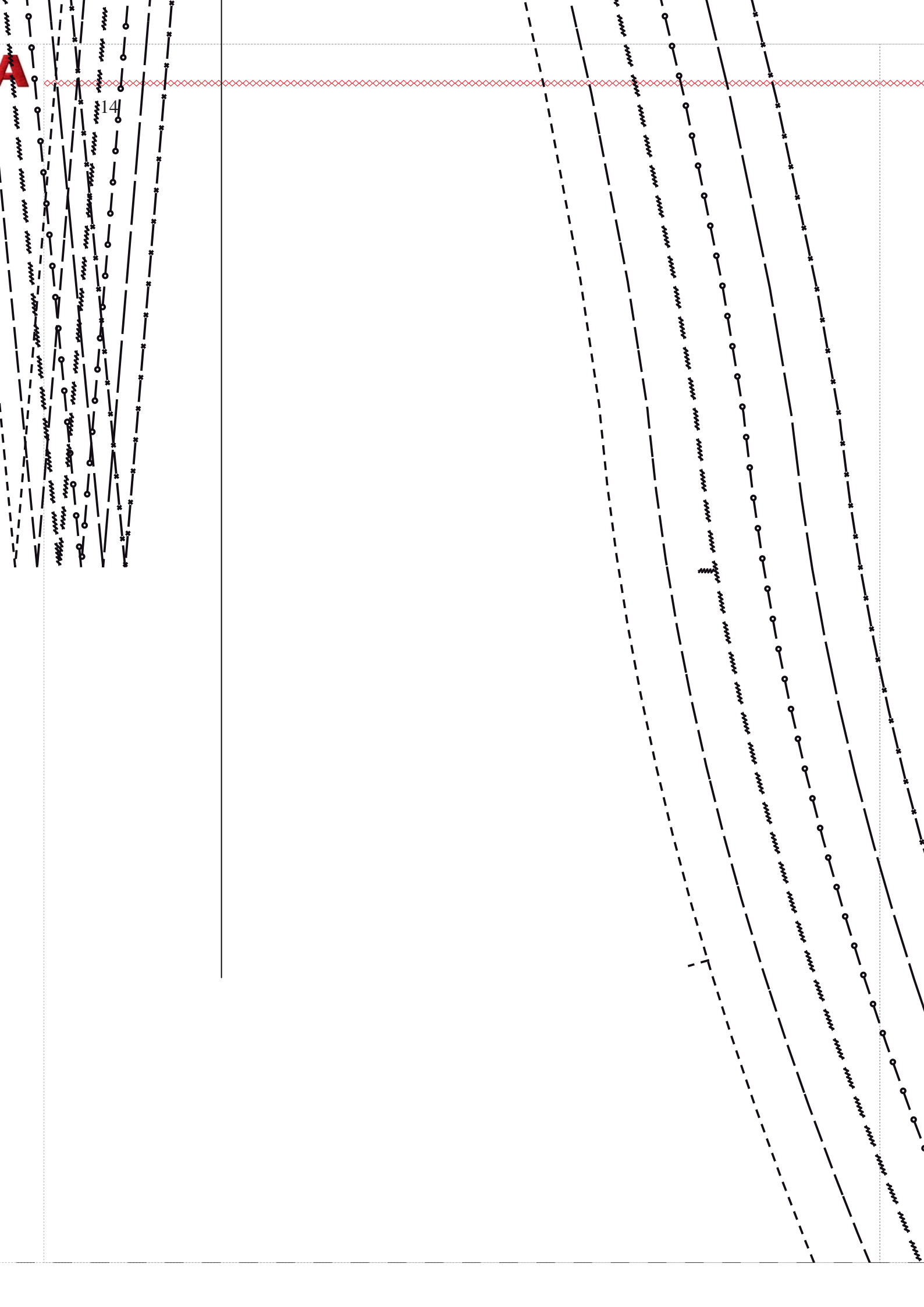

14

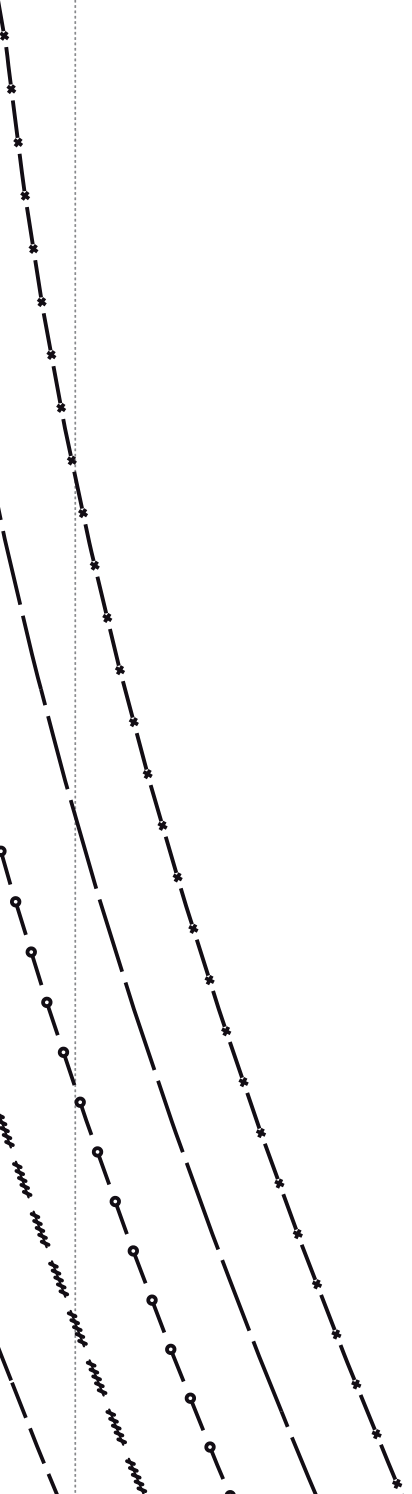
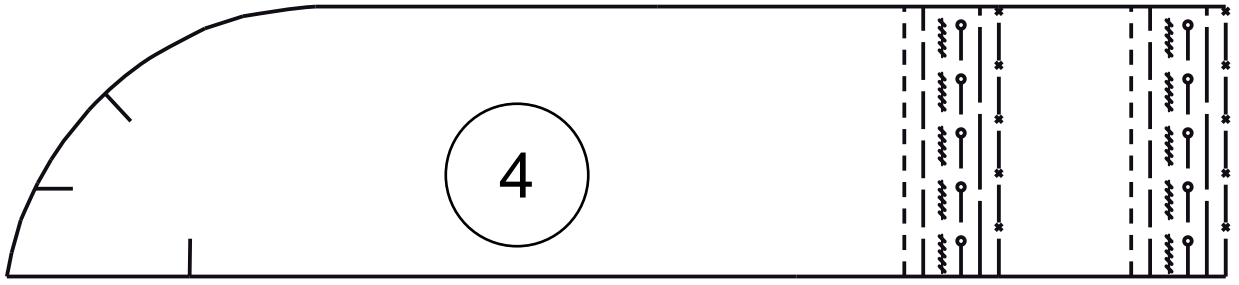

Vordere Mitte / Centre front / milieu endroit / Middenvoor

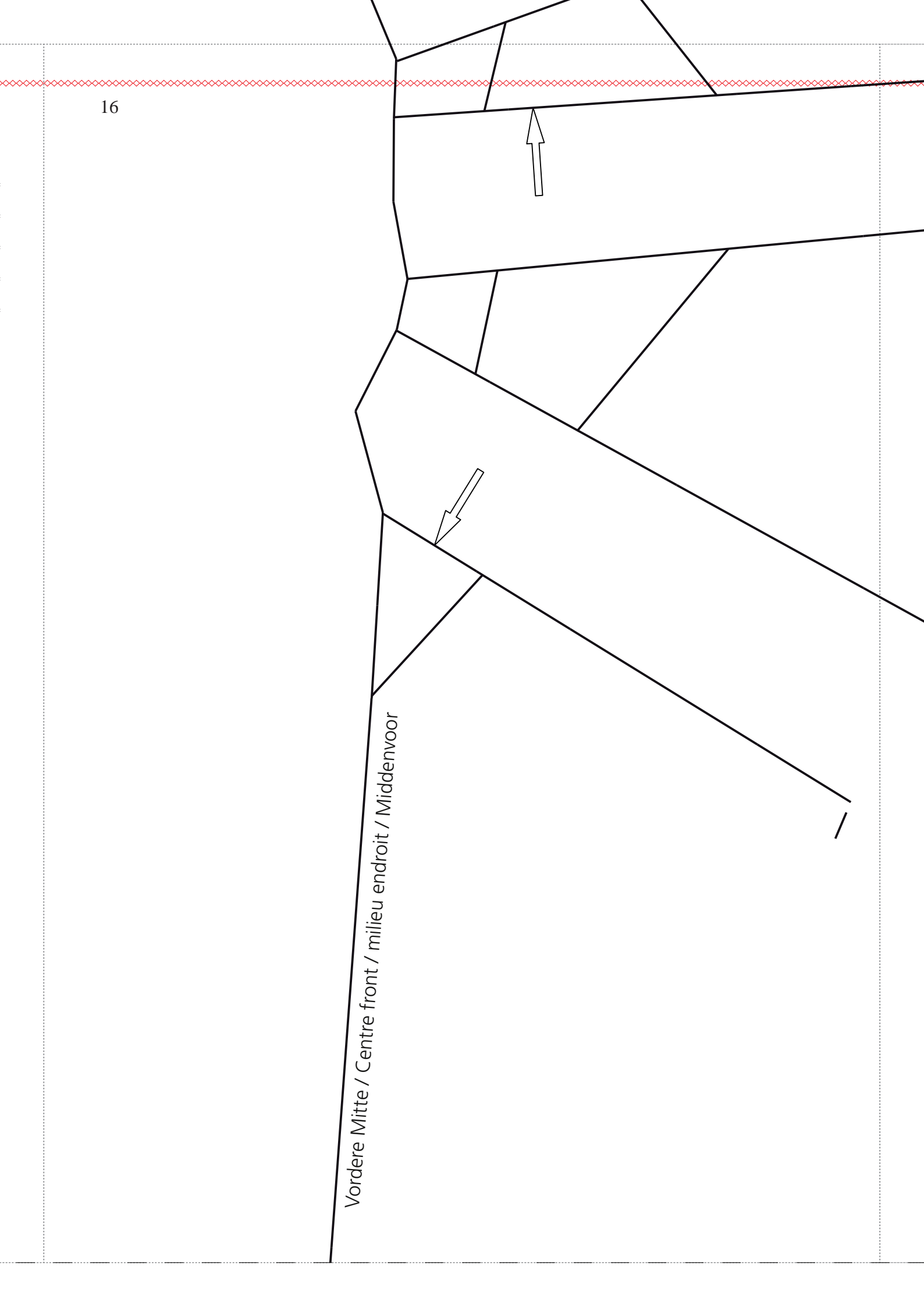

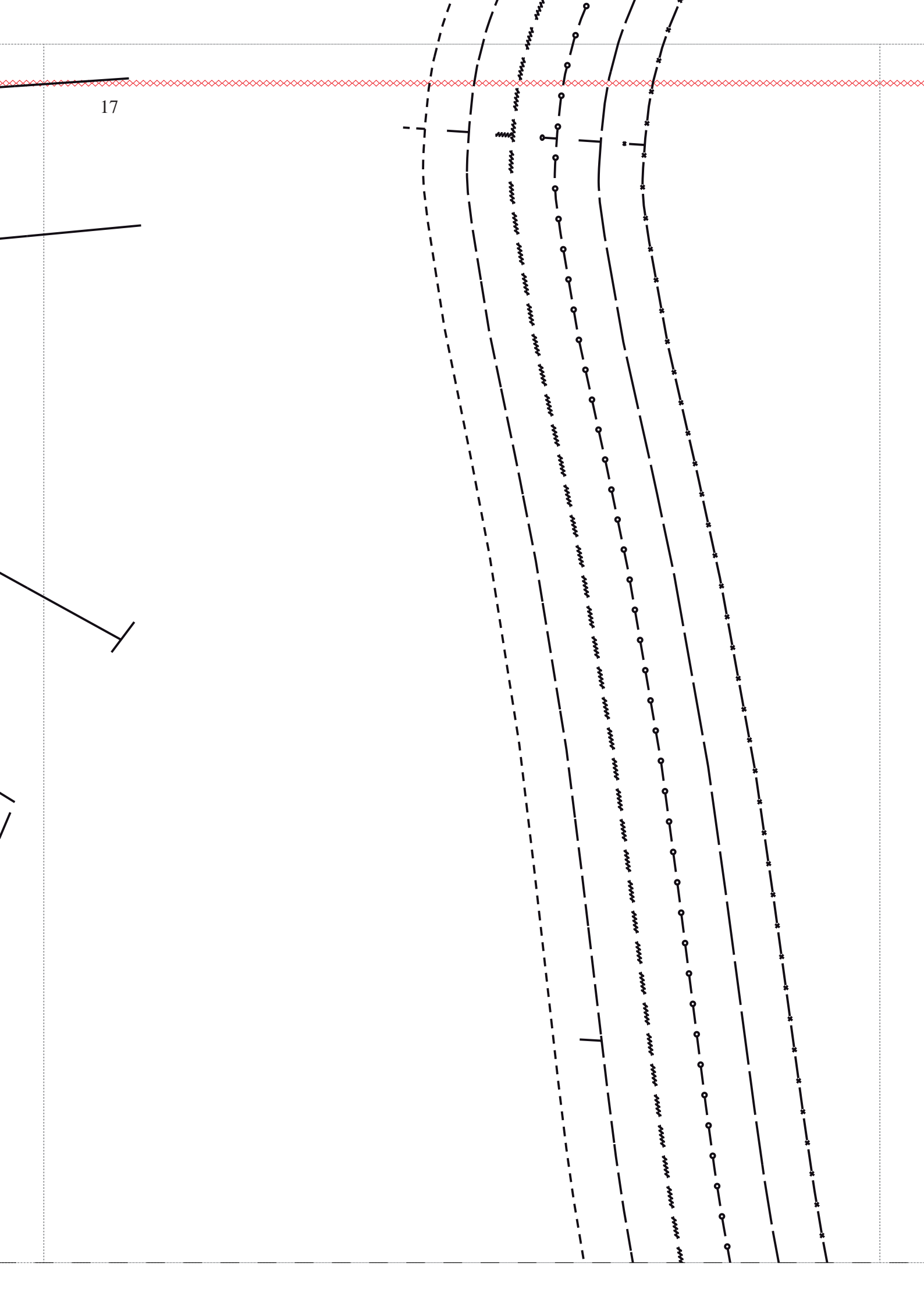



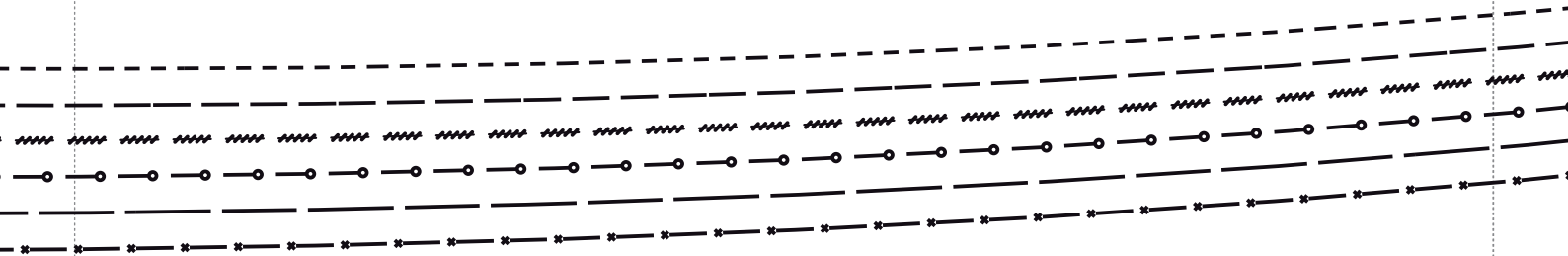

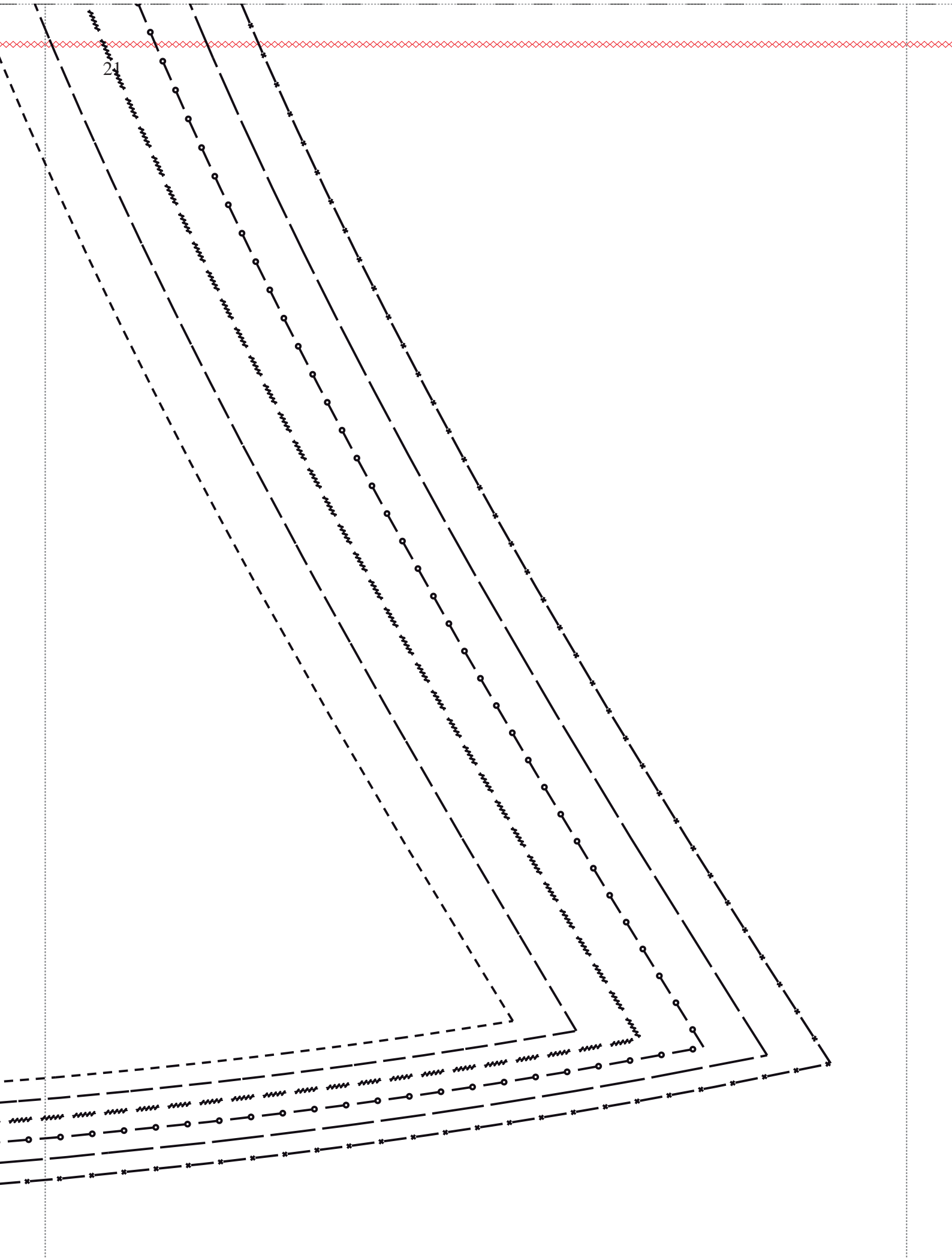

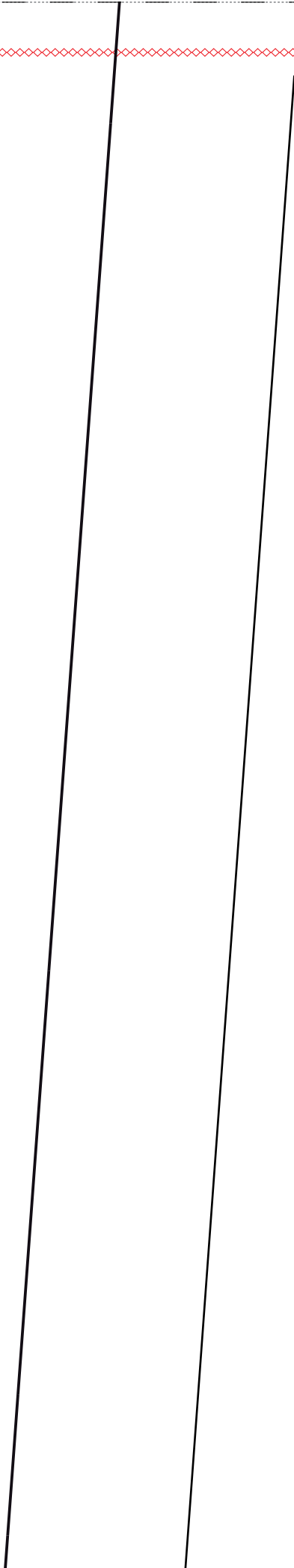

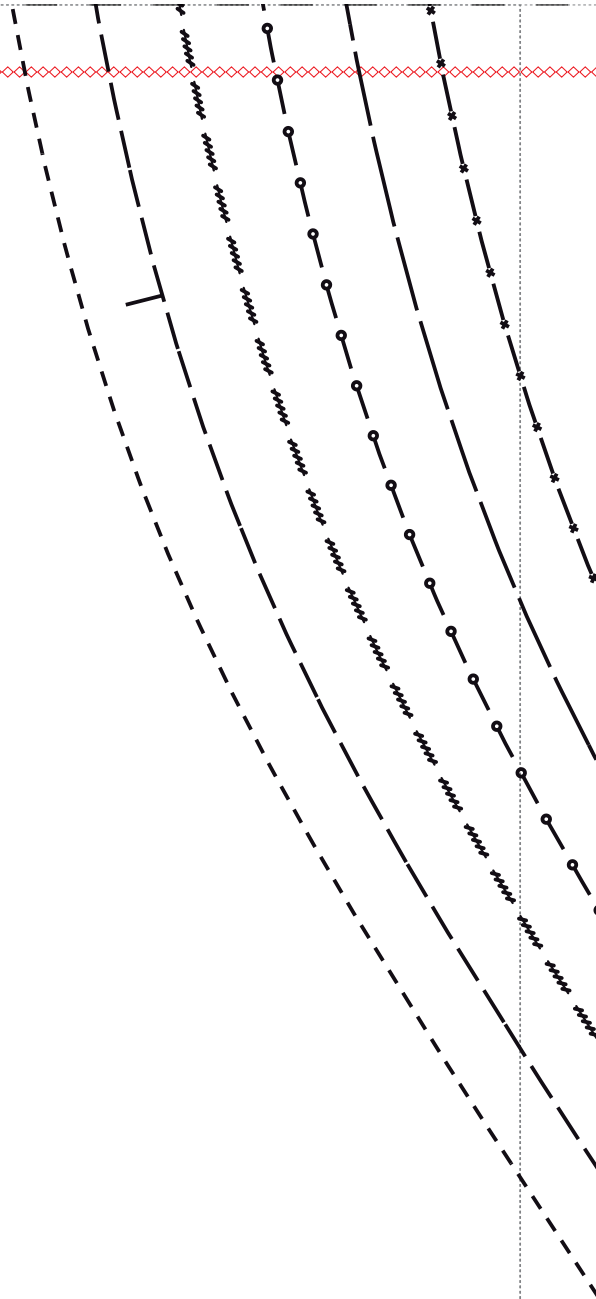

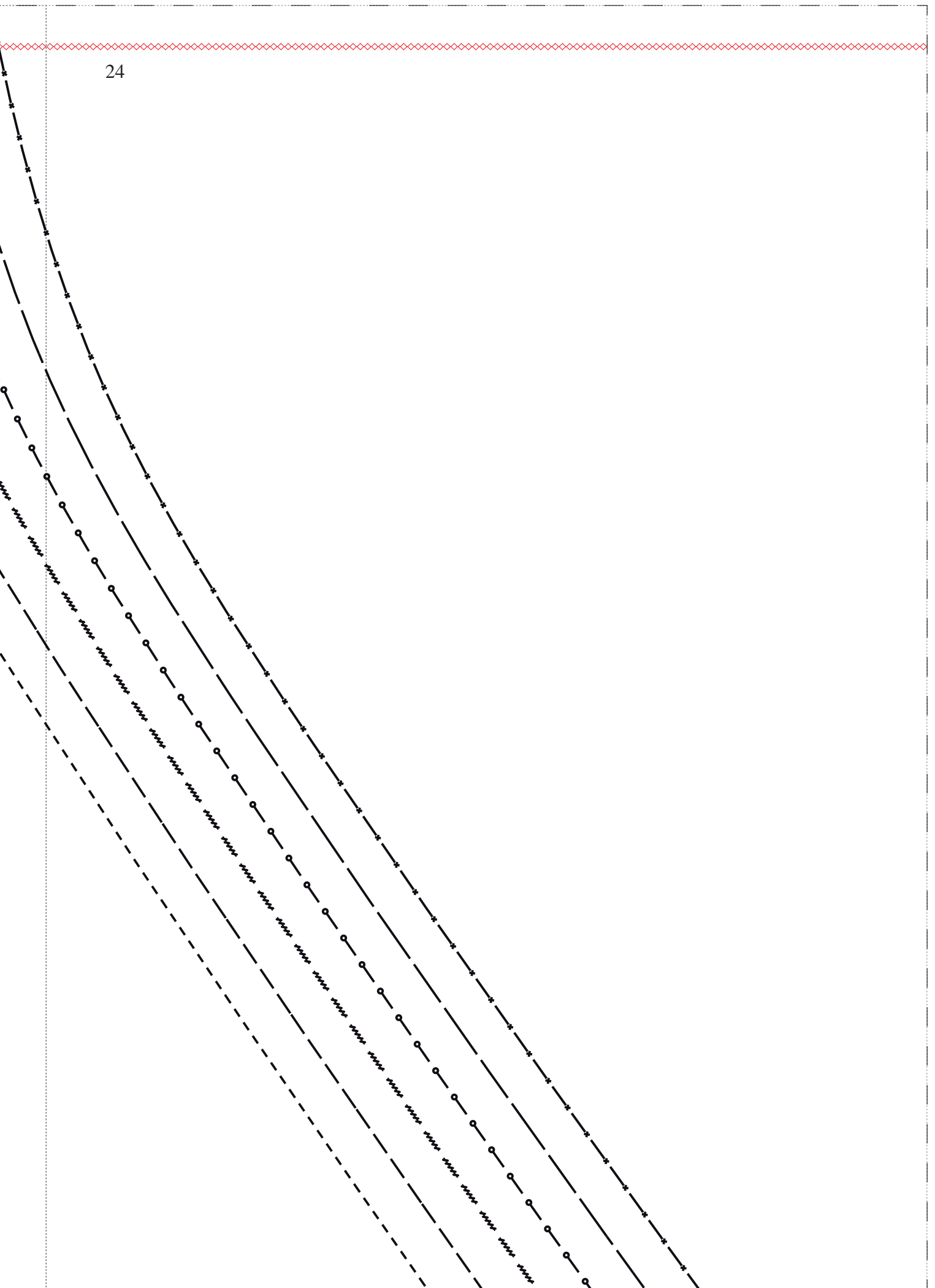

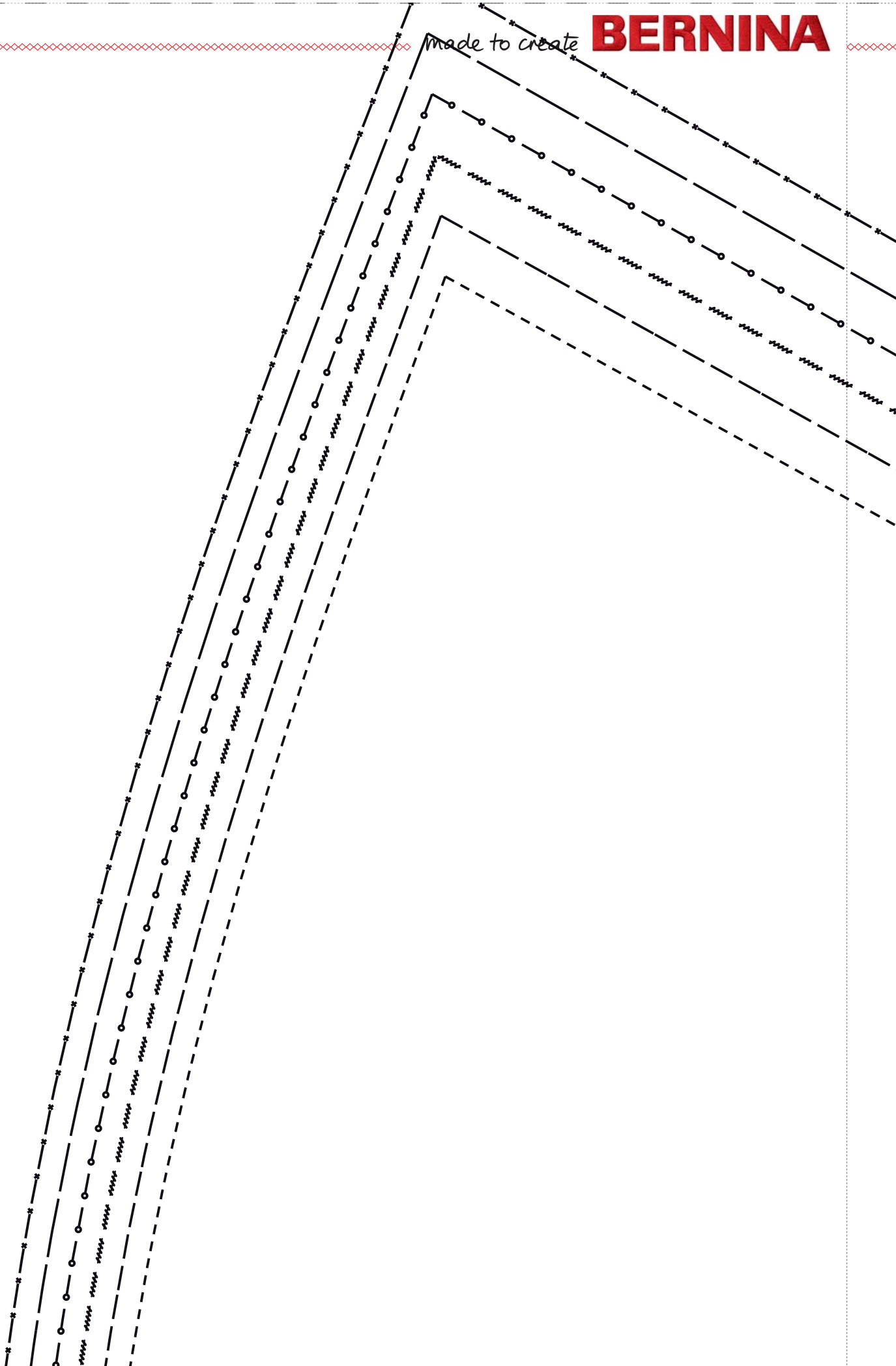

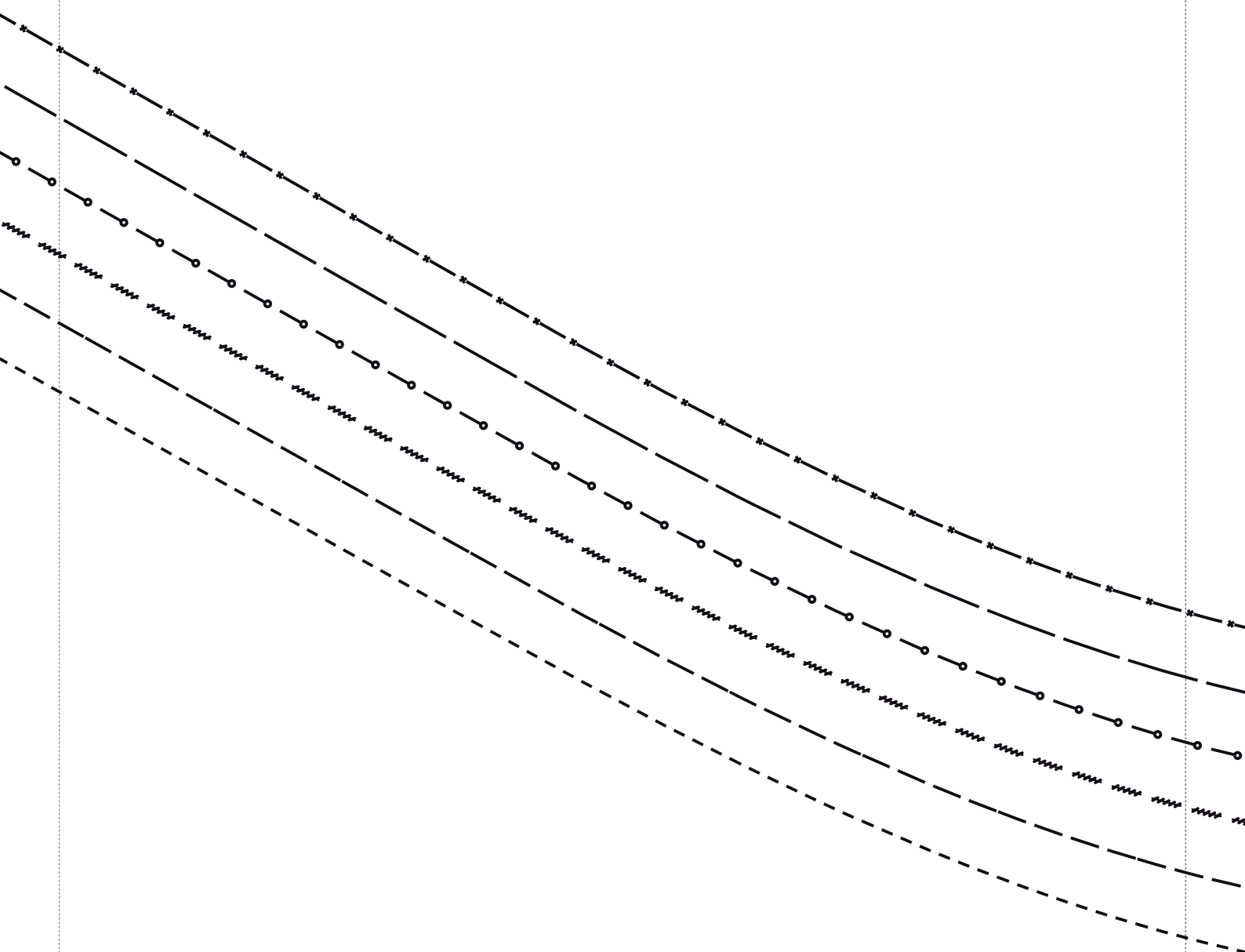

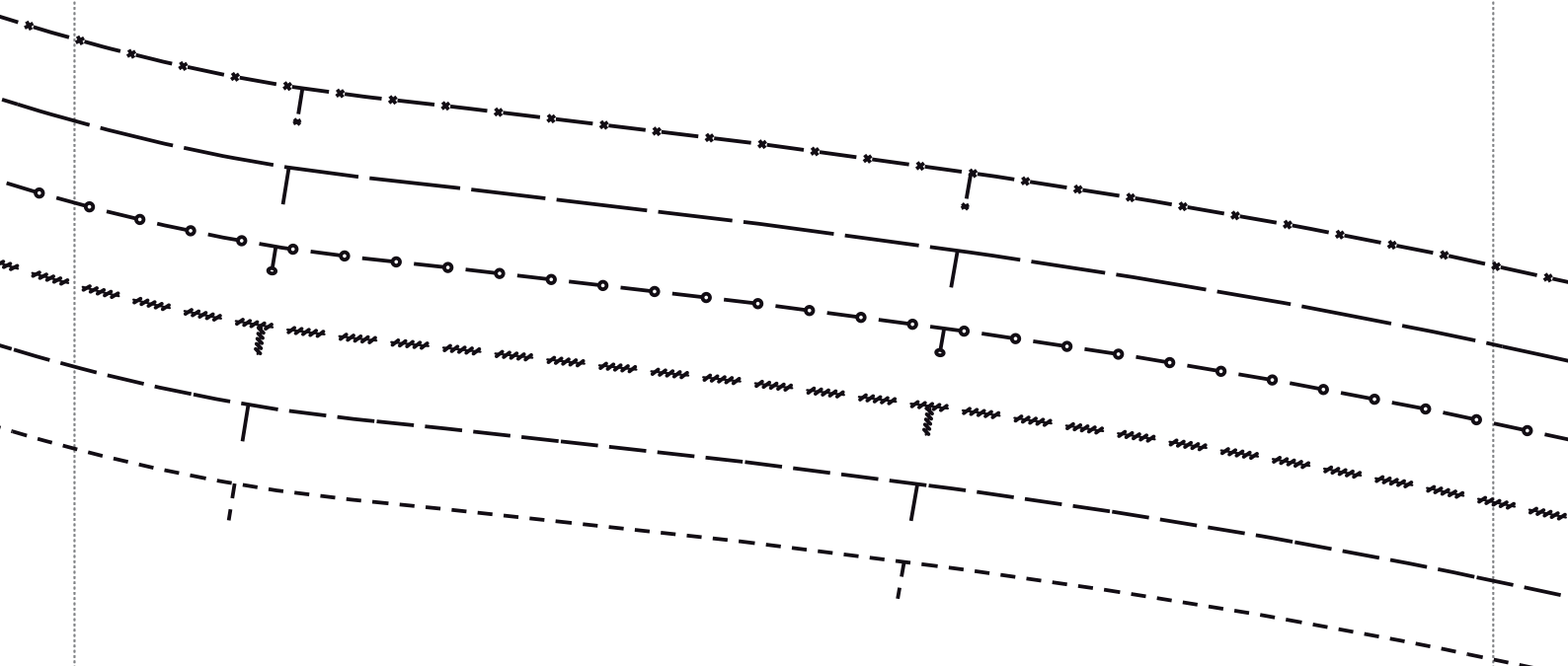



A series of horizontal and diagonal lines for handwriting practice. The top section contains a horizontal dashed line, followed by a row of wavy lines, a row of circles, another row of wavy lines, and a row of asterisks. Below these are several diagonal lines, each with a different pattern: a row of asterisks, a row of circles, a row of wavy lines, and a row of dashed lines. Some of the diagonal lines have small vertical tick marks pointing downwards.

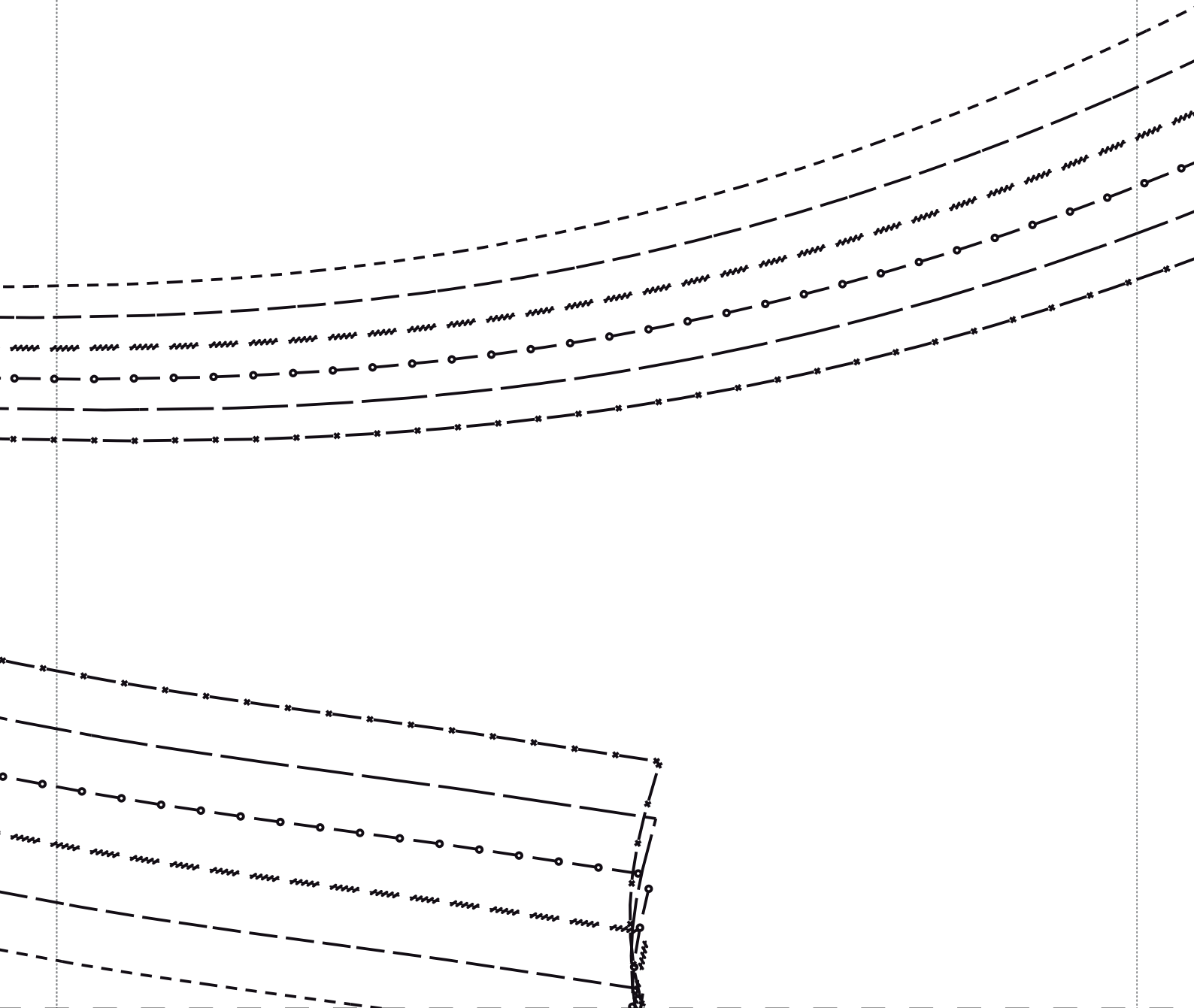

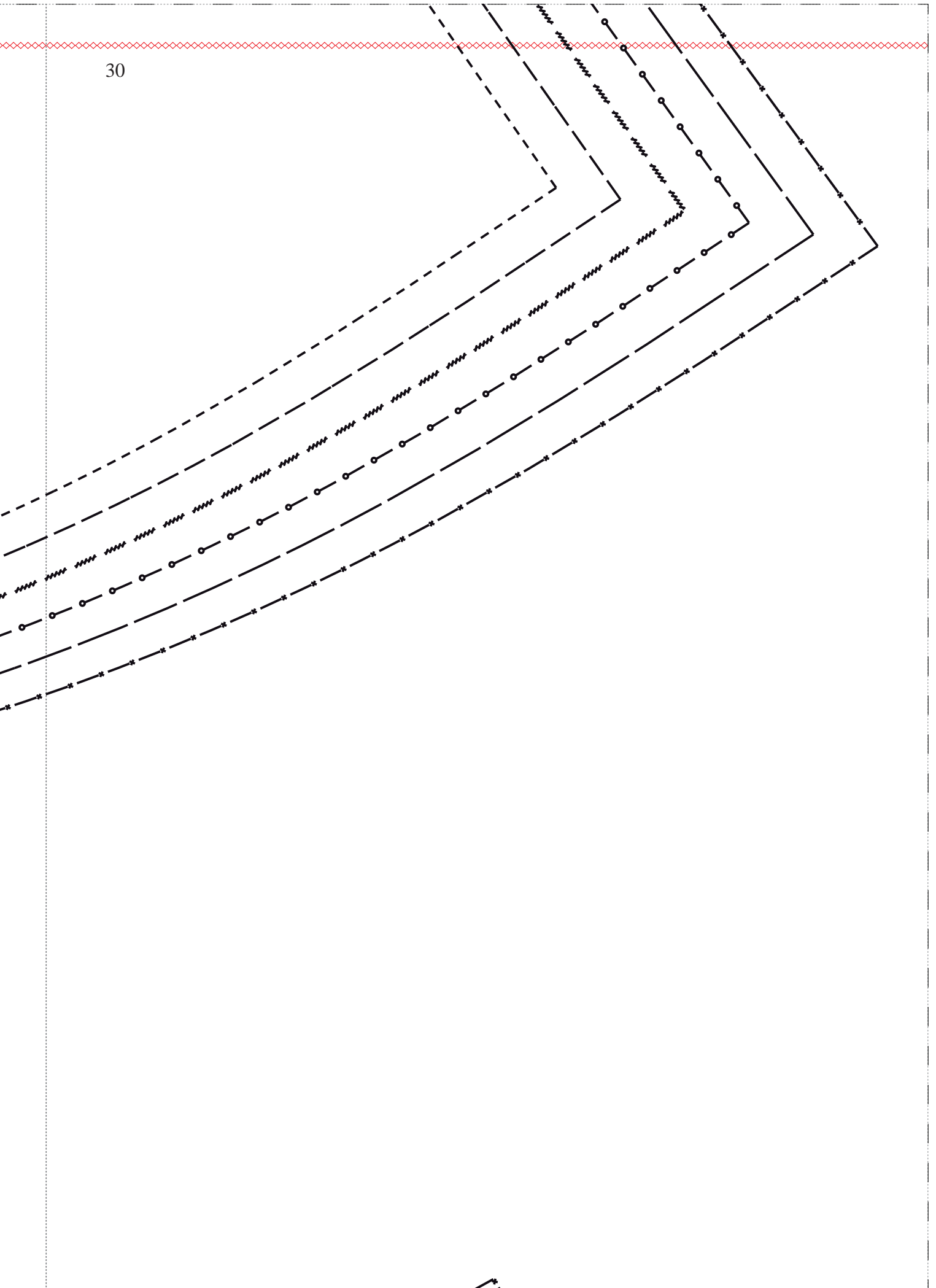

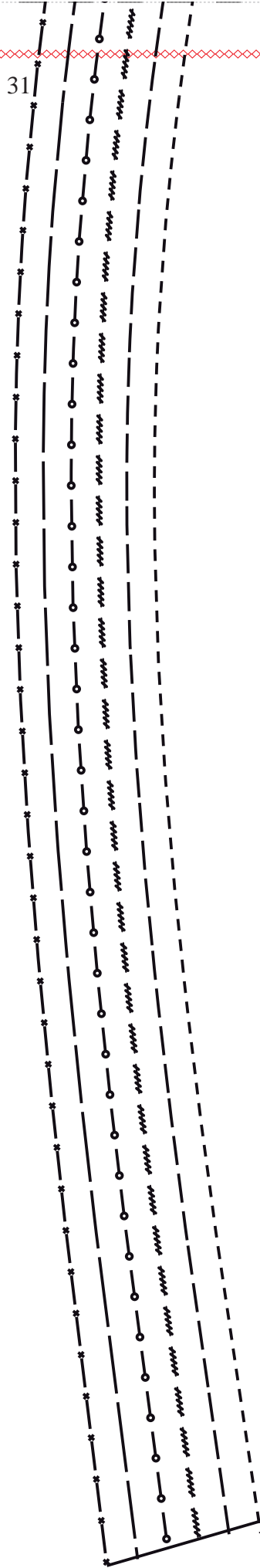

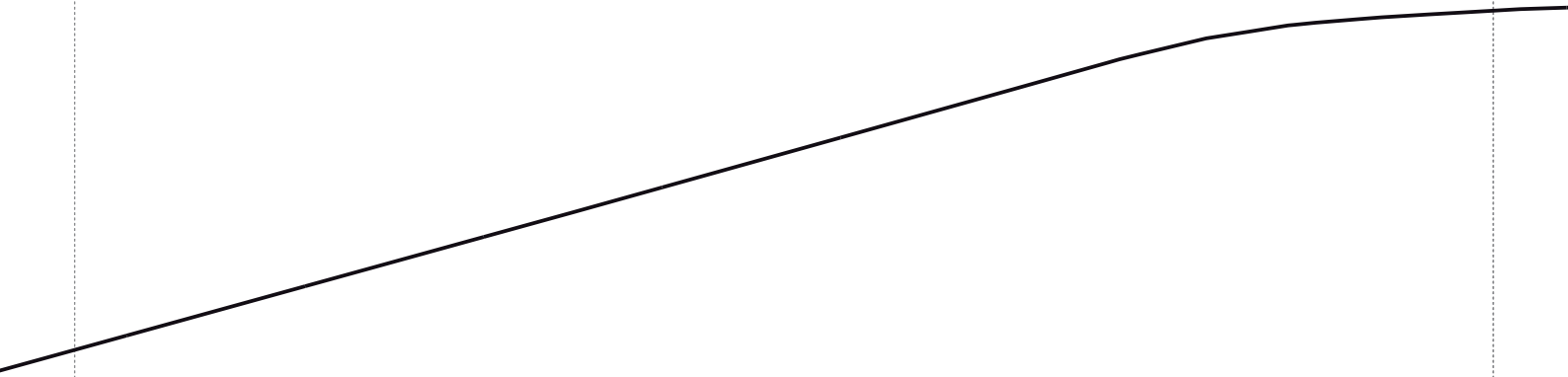
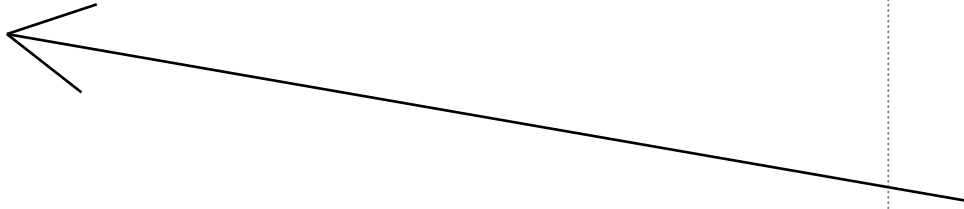

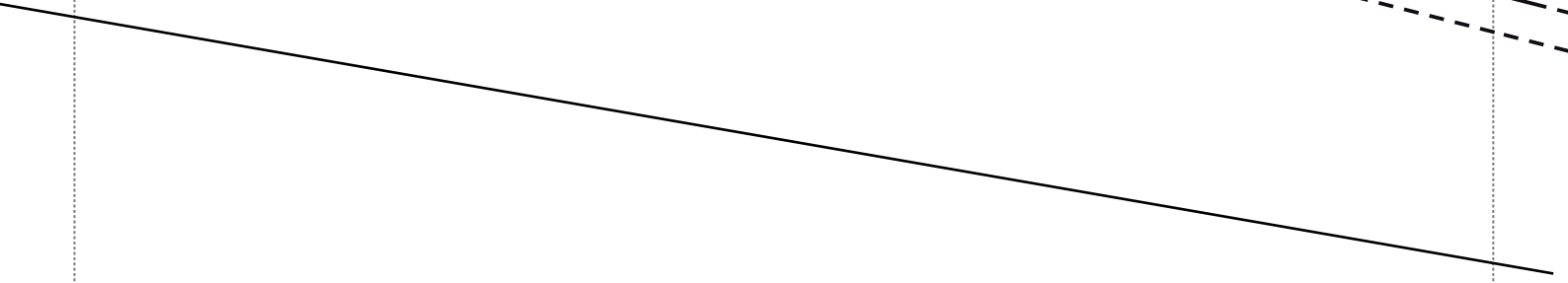
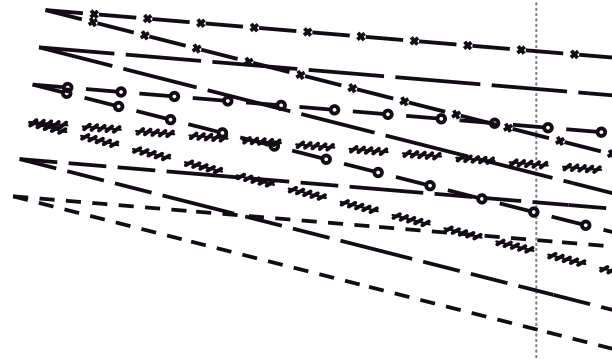

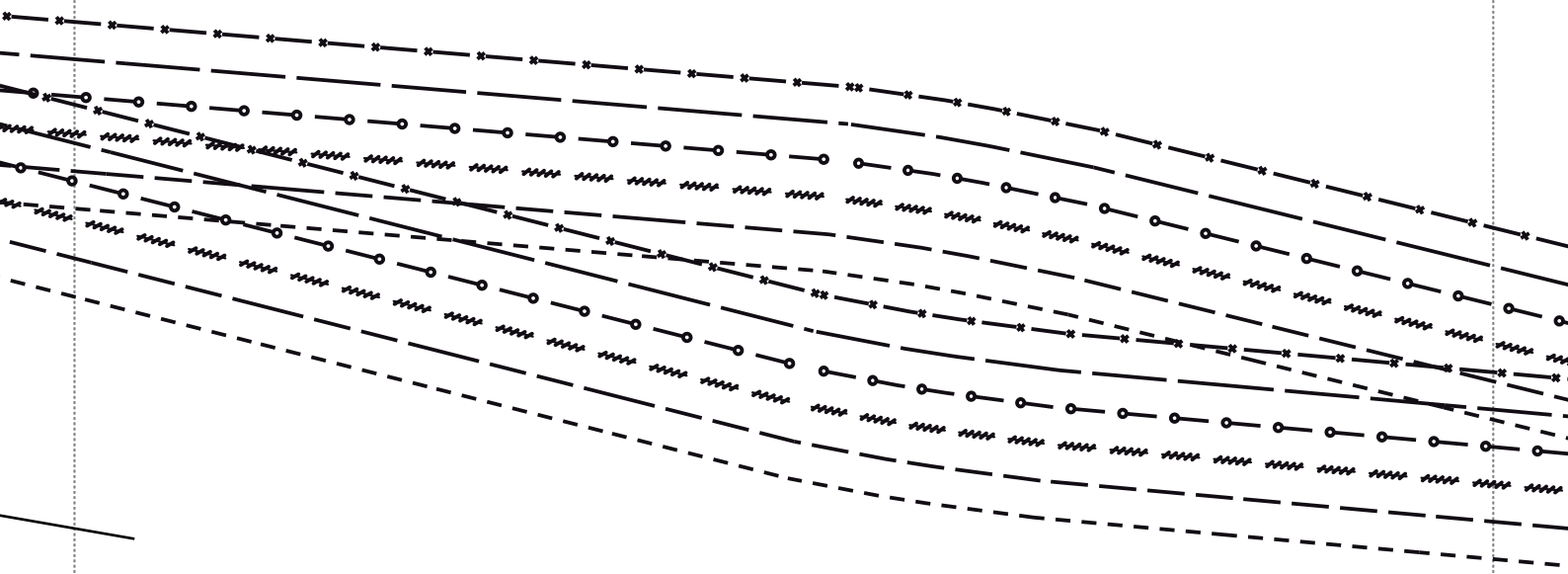

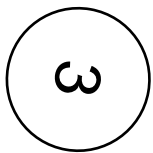
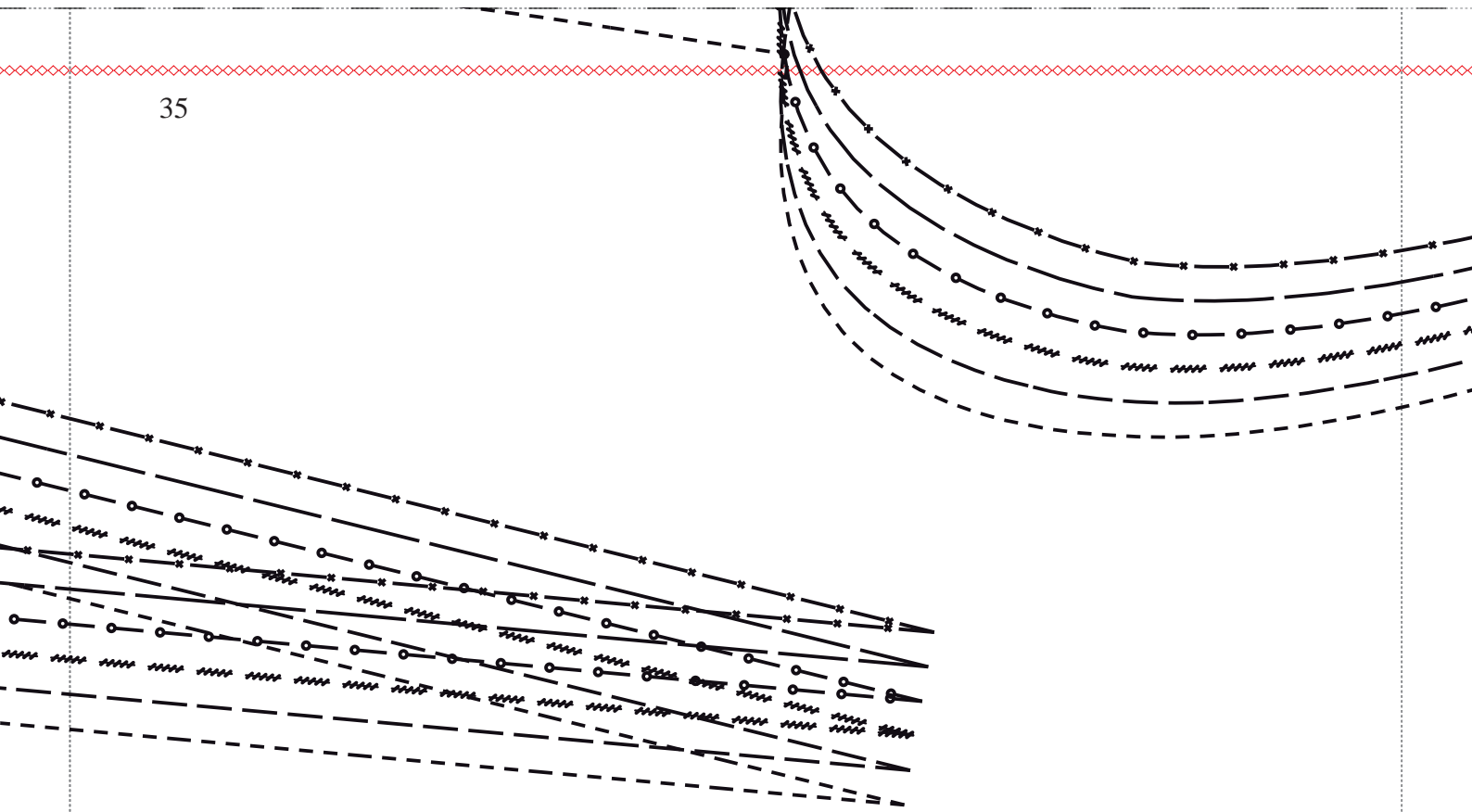

Rückwärtige Mitte / Centre back / Milieu envers / Middenachter

